

USER MANUAL

RPS-5000

Regenerative Power System



April 2026

Legal Disclaimer

The information provided in this document is subject to change without prior notice.

INFINIPOWER makes no warranty, express or implied, regarding the accuracy, completeness, or suitability of this document for any particular purpose. This includes, but is not limited to, any implied warranties of merchantability or fitness for a specific application. INFINIPOWER shall not be held liable for any errors, omissions, or damages—whether direct, indirect, incidental, or consequential—arising from the use of this document or the information contained herein.

Legal Notices

The information provided in this document is subject to change without prior notice.

INFINIPOWER Technology Co., Ltd. (hereinafter referred to as "INFINIPOWER") has made every effort to ensure the accuracy and completeness of the information contained herein. However, no explicit or implicit warranties are made regarding its suitability for any particular purpose or its merchantability. This document is intended for informational purposes only, and INFINIPOWER shall not be held liable for any direct, indirect, incidental, or consequential damages arising from the use of this document or the information contained herein. For product performance, quality, or warranty details, please refer to the official warranty documentation or specific contractual terms.

INFINIPOWER Technology Co., Ltd.

6F.-2, No. 171, Sec. 2, Datong Rd., Xizhi District, New Taipei City 221424, Taiwan

Copyright © 2025 INFINIPOWER Technology Co., Ltd. All rights reserved.

No part of this publication may be reproduced, distributed, or translated into any language in any form or by any means without the prior written permission of INFINIPOWER, except as permitted by applicable copyright laws.

Warranty Statement

INFINIPOWER warrants all products against defects in materials and workmanship under normal use and service conditions for a period of two (2) years from the date of shipment.

During this period, INFINIPOWER will, at its discretion, repair or replace any product or component that is deemed defective, provided it is returned to an authorized service center. Prior written authorization from INFINIPOWER is required before any return shipment. The purchaser is responsible for transportation costs unless the defect is reported within 30 days of shipment, in which case INFINIPOWER will cover return shipping charges.

This warranty does not apply to:

- Products that have been altered, modified, or repaired by unauthorized personnel
- Misuse, abuse, or operation outside of specified environmental or electrical conditions
- Damage caused by improper installation or external equipment
- Consumable parts such as fuses or batteries (unless otherwise specified)

INFINIPOWER shall not be liable for indirect, incidental, or consequential damages, including but not limited to loss of profits, downtime, or damage to connected systems. Liability under this warranty is strictly limited to the original purchase price of the defective unit.

All technical advice and recommendations provided by INFINIPOWER are given in good faith based on internal testing and knowledge but are not guaranteed, and the customer assumes full responsibility for verifying the suitability of the product for their specific application.

This warranty is in lieu of all other warranties, expressed or implied, and no agent or representative is authorized to alter the terms herein.

For service assistance or warranty inquiries, please contact your local distributor or visit <https://www.infinipowertech.com/>.

INFINIPOWER Technology Co., Ltd.

6F.-2, No. 171, Sec. 2, Datong Rd., Xizhi District, New Taipei City 221424, Taiwan

Service Hotline: +886-2-25175881





Email: sales@infinipowertech.com

Website: www.infinipowertech.com

Safety Precautions / Environment / Cleaning

Safety Overview

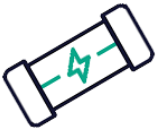
At every stage of operating this instrument, please first familiarize yourself with all usage instructions and related safety symbols associated with this product. Failure to follow these precautions, or to heed the specific warnings described in other parts of this manual, may violate the safety standards pertaining to the design, manufacturing, and intended use of the instrument. INFINIPOWER shall not be held responsible for any consequences resulting from the user's failure to comply with these safety measures.

	<p>Before Connecting to Power</p> <p>Ensure that the power source matches the rated input requirements of the device.</p>
	<p>Protective Grounding</p> <p>Before turning on the power, make sure the protective ground is properly connected to prevent electric shock.</p>
	<p>Importance of Protective Grounding</p> <p>Do not disconnect the internal or external protective ground wire, nor interrupt the connection to the protective grounding terminal. Doing so could result in potential electric shock hazards and may cause personal injury.</p>
	<p>Fuses</p> <p>Only use fuses with the specified current, voltage ratings, and designated type (standard fuse, time-delay fuse, etc.). Do not use fuses of different specifications or bypass the fuse holder, as this may cause electric shock or fire hazards.</p>
	<p>Do Not Operate in Explosive Atmospheres</p> <p>Do not operate the instrument in the presence of flammable gases or vapors. The instrument should be used in a well-ventilated environment.</p>
	<p>Do Not Remove the Instrument's Enclosure</p> <p>Operators must not remove the instrument's enclosure. Component replacement and internal adjustments should only be performed by qualified service personnel.</p>

⚠ WARNING

1. Lethal voltages – The output can reach up to 495V peak voltage.
2. Risk of fatal shock – When the power is on, contact with output terminals or circuits connected to the output may result in death.
3. Wiring precautions – When configuring the input power, ensure that all wire gauges meet the maximum current requirements.
4. Placement and installation – Before placing or installing the equipment, ensure that the floor surface is level and capable of supporting the equipment's weight. Installation should be near the main structure of the building.
5. Weight distribution – Each support foot bears approximately 150 kg. Considering floor structure, it is recommended to use 300mm x 300mm x 10t iron plates to distribute the load pressure.

Statement on Equipment and Material Contamination Control

Component Name	Hazardous or Toxic Substances and Elements					
	Lead	Cadmium	Mercury	Hexavalent Chromium	Polybrominated Biphenyls / Polybrominated Diphenyl Ethers	Phthalates
	Pb	Cd	Hg	CR ⁶⁺	PBB/PBDE	DEHP / BP / DBP / DIBP
PCBA	O	O	O	O	O	O
Chassis	O	O	O	O	O	O
Standard Accessories	O	O	O	O	O	O
Packaging Materials	O	O	O	O	O	O

O: The content of the hazardous substance in all materials of this component is below the limits specified by SJ/T 11363-2006 and EU Directive 2011/65/EU.

X: The content of the hazardous substance in a certain material of this component exceeds the limits specified by SJ/T 11363-2006 and EU Directive 2011/65/EU.

Disposal















Do not dispose of this electrical equipment as unsorted waste. This equipment must be properly categorized and recycled, or you should contact the supplier from whom you purchased the device. Please ensure that discarded electronic waste is properly recycled to minimize environmental pollution.



Declaration of Conformity



Safety Symbols and Markings

Item	Description
	AC Power Supply
	DC Power Supply
	AC/DC Power Supply
	Three-Phase AC Power Supply
	Protective Earth Terminal: In case of malfunction, this provides protection against electric shock. This symbol indicates that the terminal must be connected to earth before operating the instrument.
	Functional Earth: When protective grounding is not explicitly specified, this symbol identifies the functional grounding terminal.
	Chassis or Enclosure Terminal: This symbol identifies the terminal connected to the chassis or enclosure of the equipment.
	ON: Power On
	OFF: Power Off
	Danger: High voltage may be present. Beware of electric shock risk.
	Caution: When you see this warning symbol, please refer to the warnings and precautions listed in the manual to avoid personal injury, death, or damage to the instrument.
	High Temperature: When this symbol appears, it indicates that the area is hotter than what is safe for human contact. Do not touch to avoid personal injury.
	Warning: This symbol indicates a potential danger and reminds users to exercise extreme caution during the related operation. Improper handling or failure to follow prescribed steps may result in serious personal injury or death. Do not proceed with any operation marked by this warning until all precautions are fully understood and followed.
	Caution: This symbol indicates a potential hazard and reminds users to exercise extra care during operation. Improper handling or failure to follow specified procedures may result in product damage or loss of critical data. Do not perform any operation marked with this caution symbol unless you fully understand and meet the specified conditions.

NOTICE

Note: This symbol indicates a tip or helpful information. It provides users with additional guidance regarding operational steps, procedures, applications, or other relevant aspects. Please read carefully.

Version Revision Record

Version	Date	Revision Content
1.0	July 2024	Initial draft.

TABLE OF CONTENTS

1	OVERVIEW	11
1.1	INTRODUCTION	11
1.2	KEY FEATURES	12
1.3	MODEL LIST	12
1.4	SPECIFICATIONS	13
2	DEVICE INTRODUCTION	17
2.1	UNBOXING INSPECTION	17
2.2	DIMENSIONS	18
2.3	TRANSPORTATION	19
2.4	FUNCTION KEY DESCRIPTION	21
2.4.1	Front Panel	21
2.4.2	Rear Panel	22
3	INSTALLATION	25
3.1	ENVIRONMENTAL CONDITIONS	25
3.2	MAINTENANCE AND CARE	25
3.3	INPUT POWER SPECIFICATIONS	26
3.3.1	Rated Values	26
3.3.2	Input Wiring	27
3.4	OUTPUT WIRING	29
3.4.1	Connecting the DUT (Local Sensing)	30
3.4.1	Connecting the DUT (Remote Sensing)	32
4	OPERATION INSTRUCTIONS	35

4.1	POWER-ON PROCEDURE.....	35
4.2	MAIN SCREEN OVERVIEW.....	36
4.3	MAIN SCREEN OPERATION.....	43
4.3.1	Parameter Setting and Test Execution	43
4.3.2	Numeric Keypad.....	45
4.3.3	Rotary Knob Operation Instructions	46
4.3.4	Measurement Parameter Selection.....	47
4.3.5	Setting Parameter View Box	51
4.3.6	Measurement Display and Function Menu.....	51
4.4	MAIN MENU FUNCTION DESCRIPTION	56
4.5	OUTPUT CONFIGURATION SETTING (OUTPUT CONFIG).....	57
4.5.1	Output Phase Switching (Output Phase).....	58
4.5.2	Advanced Mode Setting (Source Mode)	61
4.5.3	Phase Output Setting	61
4.5.4	Output Setting.....	69
4.5.5	Output Slew Rate Setting (Slew Rate).....	77
4.5.6	Inrush Current Measurement Function (Isurge).....	80
4.5.7	Programmable Output Impedance (Impedance).....	82
4.6	OUTPUT WAVEFORM SELECTION (WAVE SELECT)	84
4.7	SYSTEM-WIDE PARAMETER SAVE/LOAD.....	88
4.8	OUTPUT PROTECTION SETTINGS (PROTECTION).....	90
4.9	INFORMATION.....	96
5	ADVANCED MODE SETTING.....	98
5.1	BASE MODE (BASE).....	99
5.2	LIST MODE (LIST).....	100

5.3	STEP MODE (STEP).....	107
5.4	PULSE MODE (PULSE).....	111
5.5	SYNTHESIS MODE (SYNTHESIS).....	115
5.6	INTERHARMONIC MODE (INTERHARMONIC).....	119
5.7	TRANSIENT WAVEFORM MODE (TRANSIENT).....	124
6	SYSTEM FUNCTION DESCRIPTION	129
6.1	MODE SWITCHING (DEVICE FUNCTION).....	130
6.2	REMOTE SENSE FUNCTION.....	130
6.3	REMOTE OUTPUT CONTROL.....	131
6.4	EXTERNAL VOLTAGE REFERENCE INPUT FUNCTION (EXTERNAL V-REF.).....	133
6.5	OUTPUT VOLTAGE/CURRENT MONITORING FUNCTION (EXTERNAL V/I MONITOR).....	134
6.6	OUTPUT STATE SETTING (POWER ON OUTPUT).....	136
6.7	PARALLEL CONNECTION SETTING (PARALLEL CONNECT).....	138
6.8	OUTPUT SETTING LIMITS (SETTING LIMIT).....	139
6.8.1	AC Output Voltage Setting Limit (Vac Setting Limit).....	140
6.8.2	DC Output Voltage Setting Limit (Vdc Setting Limit).....	141
6.8.3	Output Frequency Setting Limit (Freq Setting Limit).....	142
6.9	SCREEN BRIGHTNESS SETTING (DISPLAY BRIGHTNESS).....	143
6.10	BUZZER VOLUME SETTING.....	144
6.11	DATE/TIME.....	145
6.12	LANGUAGE.....	145
6.13	SYSTEM STATUS MONITORING INTERFACE (STATUS PANEL).....	146
6.14	TOUCHSCREEN LOCK FUNCTION (STOP TOUCH).....	146
6.15	RESTORE FACTORY SETTINGS (FACTORY DEFAULT).....	148
7	PROTECTION LIST DESCRIPTION	152

8	CALIBRATION AND VERIFICATION	160
8.1	CALIBRATION AND VERIFICATION	160
8.2	ENTERING THE CALIBRATION PROCEDURE.....	161
8.2.1	Voltage Setting and Measurement Calibration	163
8.2.2	Current Measurement Calibration	170
9	REGENERATIVE LOAD FUNCTION DESCRIPTION	175
9.1	MAIN SCREEN OVERVIEW.....	175
9.2	MAIN SCREEN OPERATION.....	176
9.2.1	Parameter Setting and Test Execution	176
9.3	ADVANCED MODE SETTINGS	178
9.3.1	Constant Current Mode (CC Mode)	179
9.3.2	Constant Power Mode(CP Mode).....	180
9.3.3	Constant Apparent Power Mode(CS Mode).....	181
9.3.4	Constant Resistance Mode(CR Mode).....	183
9.3.5	Load Impedance Simulation Mode(CZ Mode).....	184
9.3.6	Constant Current Phase Mode (CCPH Mode)	185
9.3.7	Constant Power Phase Mode (CPPH Mode).....	187
9.3.8	Constant Apparent Power Phase Mode (CSPH Mode).....	188
10	BUILT-IN WAVEFORM LIBRARY	190
10.1	WAVEFORM DST1	191
10.2	WAVEFORM DST2	191
10.3	WAVEFORM DST3	191
10.4	WAVEFORM DST4	192
10.5	WAVEFORM DST5	192
10.6	WAVEFORM DST6	192

10.7	WAVEFORM DST7	193
10.8	WAVEFORM DST8	193
10.9	WAVEFORM DST9	193
10.10	WAVEFORM DST10	194
10.11	WAVEFORM DST11.....	194
10.12	WAVEFORM DST12	195
10.13	WAVEFORM DST13	195
10.14	WAVEFORM DST14	195
10.15	WAVEFORM DST15	196
10.16	WAVEFORM DST16	196
10.17	WAVEFORM DST17	196
10.18	WAVEFORM DST18	197
10.19	WAVEFORM DST19	197
10.20	WAVEFORM DST20	197
10.21	WAVEFORM DST21	198
10.22	WAVEFORM DST22	198
10.23	WAVEFORM DST23	199
10.24	WAVEFORM DST24	199
10.25	WAVEFORM DST25	199
10.26	WAVEFORM DST26	200
10.27	WAVEFORM DST27	200
10.28	WAVEFORM DST28	200
10.29	WAVEFORM DST29	201
10.30	WAVEFORM DST30	201
11	EXTERNAL I/O PIN FUNCTIONS.....	202

12	REMOTE OPERATION	204
12.1	USB INTERFACE	204
12.2	RS-232 INTERFACE	205
12.3	ETHERNET INTERFACE	206
12.4	GPIB INTERFACE	207
13	SCPI PROGRAMMING COMMAND	208
13.1	IEEE COMMON COMMANDS	210
13.2	INSTRUMENT SUBSYSTEM	212
13.3	[SOURCE:]VOLTAGE SUBSYSTEM	215
13.4	[SOURCE:]CURRENT SUBSYSTEM	218
13.5	[SOURCE:]FREQUENCY SUBSYSTEM	221
13.6	[SOURCE:]POWER	222
13.7	[SOURCE:]FUNCTION	224
13.8	OUTPUT SUBSYSTEM	231
13.9	TRIG SUBSYSTEM	238
13.10	PHASE SUBSYSTEM	239
13.11	FETCH AND MEASURE SUBSYSTEMS	244
13.12	[SOURCE:]LIST SUBSYSTEM	259
13.13	[SOURCE:]STEP SUBSYSTEM	271
13.14	[SOURCE:]PULSE SUBSYSTEM	279
13.15	[SOURCE:]SYNTHESIS SUBSYSTEM	285
13.16	[SOURCE:]INTERHARM SUBSYSTEM	292
13.17	[SOURCE:]TRANSIENT SUBSYSTEM	294
13.18	SYSTEM CONFIG SUBSYSTEM	300
13.19	INFORMATION SUBSYSTEM	314

13.20 FILE SUBSYSTEM319

13.21 CALIBRATION SUBSYSTEM320

13.22 OVERALL COMMAND TABLE323

1 Overview

1.1 Introduction

The RPS-5000 Series Regenerative Power System is a high-performance testing device designed to simulate a wide range of grid conditions. It is a full four-quadrant regenerative AC power source that also functions as a regenerative AC/DC electronic load. Unlike traditional resistive loads, it feeds excess power generated during testing back to the grid, meeting environmental requirements while significantly reducing electricity consumption and cooling costs.

This power system utilizes advanced digital control technology, offering a wide output voltage and current range, high-precision output characteristics, multiple output modes, and harmonic generation capabilities. It can simulate complex grid conditions to accommodate diverse testing needs. This makes it an ideal solution for a variety of compliance testing applications, including power electronic equipment (IEC 61000), electric vehicle chargers (IEC 61851 / GB/T 18487.1), and renewable energy systems (IEC 62116 / IEEE 1547). It meets a range of international standards and regulatory requirements, ensuring test results are both compliant and reliable, and providing dependable technical support for both R&D and production.



1.2 Key Features

- Output Voltage: 0 – 350V
- Output Frequency: DC, 30 – 150Hz
- Wide AC current output range
- Supports parallel configuration with master-slave current sharing
- Full four-quadrant regenerative power system with 100% rated apparent power feedback capability
- Touchscreen panel design with intuitive user interface
- Adjustable voltage and frequency slew rate
- Configurable voltage and current output limits
- Programmable on/off phase angle from 0 to 360 degrees
- Selectable output configurations: single-phase, three-phase, or split-phase (expandable up to 200% of rated voltage)
- Three operating modes: Constant Voltage (CV), Constant Current (CC), and Constant Power (CP)
- LIST, STEP, PULSE, and Transient (surge and sag) modes for simulating power line disturbance (PLD) testing
- Harmonic disturbance and waveform synthesis
- Voltage and current measurement capabilities supporting up to the 50th harmonic
- Complies with grid connection standards for LVRT, phase shift, frequency variation, and harmonic injection tests
- Rich waveform database
- Conforms to IEC 61000-4-11 / 4-13 / 4-14 / 4-28 / 4-34 standard waveform testing
- Programmable simulation interface (suitable for PHIL simulation tests)
- Standard USB, LAN, RS-232, and external I/O interfaces
- Optional GPIB and CAN interfaces

1.3 Model List

Model	Rated Power	AC Voltage Range	Frequency Range	Current	Single-Phase Max Current	DC Voltage Range	DC Current Range
RPS-5030	30kVA	0-350V	30-150Hz	66.7(Arms) 183(Apeak)	200(Arms) 550(Apeak)	±495Vdc	± 200Adc
RPS-5045	45kVA	0-350V	30-150Hz	100(Arms) 275(Apeak)	300(Arms) 825(Apeak)	±495Vdc	± 300Adc

1.4 Specifications

The operating specifications of the RPS-5030 and RPS-5045 are shown in the table below. All specifications have been tested according to INFINIPOWER's standard testing procedures. Unless otherwise specified, all specifications are measured at a temperature of $25 \pm 1^\circ\text{C}$ under resistive load conditions.

Model	RPS-5030	RPS-5045
AC Input		
Phase	3Ø3W	
Voltage	200 - 220 VL-L \pm 10% 380 - 400 VL-L \pm 10% 440 - 480 VL-L \pm 10%	
Frequency	47 - 63Hz	
Max. Current	124A/phase (200 - 220 VL-L \pm 10%) 66A/phase (380 - 400 VL-L \pm 10%) 58A/phase (440 - 480 VL-L \pm 10%)	186A/phase (200 - 220 VL-L \pm 10%) 99A/phase (380 - 400 VL-L \pm 10%) 87A/phase (440 - 480 VL-L \pm 10%)
Power Factor(*1)	0.98(Typical)	
AC Output		
Phase Modes	Three, Single or Split selectable	Three, Single or Split selectable
Max. Power	30kVA/20kVA (Split phase)	45kVA/30kVA(Split phase)
Per Phase/Channel	10kVA	15kVA
AC Voltage		
Range	0 - 350VL-N, 0 - 606VL-L, 0-700VL-L(Split phase) Option : 0 - 400VL-N, 0 - 692VL-L, 0-800VL-L(Split phase)	
Resolution	0.1V	
Setting Accuracy	\pm (0.1% of setting + 0.2% F.S.)	
Total Harmonic Distortion (THD)(*2)	<0.4% @ 50/60Hz <0.9% @ 30-150Hz	
Line Regulation	\pm 0.1%	
Load Regulation (*3)	\pm 0.2%	
Phase Angle	Range	0 - 359.9°
	Resolution	0.1°
Maximum AC Current		
RMS(*4)	200A(Single)/66.7A(Three/Split)	300A(Single)/100A(Three/Split)
Peak	550A(Single)/183A(Three/Split)	825A(Single)/275A(Three/Split)
Crest Factor	2.75	2.75
Frequency		
Range	30.00 – 150.00Hz	
Resolution	0.01Hz	
Accuracy(*5)	\pm 0.01% F.S	
DC Output		
Max. Power	30kW/20kW (Split phase)	45kW/30kW(Split phase)
Per Phase/Channel	10kW	15kW
DC Voltage		
Range	\pm 495VDC, \pm 990VDC(Split phase)	

	Option : $\pm 565\text{VDC}$, $\pm 1130\text{VDC}$ (Split phase)			
Resolution	0.1V			
Setting Accuracy	$\pm (0.1\% \text{ of setting} + 0.2\% \text{ F.S.})$			
Maximum DC Current				
Range	200A(Single)/66.7A(Three/Split)		300A(Single)/100A(Three/Split)	
Harmonic Synthesis Function				
up to 50 Harmonic order @ 50/60Hz fundamental frequency				
Energy Regeneration Function				
Max. Regenerative Power	30kVA		45kVA	
Current Total Harmonic Distortion (iTHD)(*6)	<7%(Typical)		<5%(Typical)	
Power Factor(*7)	0.97(Typical)			
Constant Current Function				
Setting	Range	Single phase	0.1 - 200.0A	0.1 - 300.0A
		Three/Split phase	0.1 - 66.7A	0.1 - 100.0A
	Resolution		0.1A	
	Accuracy		$\pm (2.0\% \text{ of setting} + 0.5\% \text{ F.S.})$	
Response Time		< 0.5s		
Measurement				
Voltage (AC)	Range		0 - 350VL-N, 0 - 606VL-L, 0 - 700VL-L(Split) Option : 0 - 400VL-N, 0 - 692VL-L, 0 - 800VL-L(Split)	
	Resolution		0.01V	
	Accuracy		$\pm (0.1\% \text{ of reading} + 0.2\% \text{ F.S.})$ at Voltage > 5V	
Voltage (DC)	Range		$\pm 495\text{VDC}$, $\pm 990\text{VDC}$ (Split phase) Option : $\pm 565\text{VDC}$, $\pm 1130\text{VDC}$ (Split phase)	
	Resolution		0.01V	
	Accuracy		$\pm (0.1\% \text{ of reading} + 0.2\% \text{ F.S.})$ at Voltage > 5V	
Current (AC,DC)	Range	Single phase	0.00 - 200.00A	0.00 - 300.00A
		Three/Split phase	0.00 - 66.70A	0.00 - 100.00A
	Resolution		0.01A	
	Accuracy		$\pm (0.4\% \text{ of reading} + 0.3\% \text{ F.S.})$	
Peak Current	Range	Single phase	0.0 - 550.0Apk	0.0 - 825.0Apk
		Three/Split phase	0.0 - 183.0Apk	0.0 - 275.0Apk
	Resolution		0.1A	
	Accuracy		$\pm (0.4\% \text{ of reading} + 0.6\% \text{ F.S.})$	
Power (AC,DC)	Range	Single phase	0.0W - 30kW	0.0W - 45kW
		Three phase	0.0W - 10kW	0.0W - 15kW
		Split phase	0.0W - 20kW	0.0W - 30kW
	Resolution		0.1W at 0.0 - 9999.9W 1W at Power $\geq 10000\text{W}$	
	Accuracy		$\pm (0.4\% \text{ of reading} + 0.4\% \text{ F.S.})$	
Power Factor	Range		0 - 1.000	
	Resolution		0.001	
	Accuracy		W / VA , Calculated and displayed to three significant digits	

Crest Factor	Range	0 - 10.00
	Resolution	0.01
	Accuracy	Ap / A , Calculated and displayed to two significant digits
Harmonic Measurement	Range	up to 50 Harmonic order @ 50/60Hz fundamental frequency
Others		
Interface	Standard: USB, RS232, Ethernet , External I/O(DB25) Option : GPIB, CAN Bus	
Protection	OCP, OVP, OPP, OTP, SHORT, FAN	
Multi Language	EN, TC, SC	
Efficiency(*8)	90% (Typical)	
V sense	Yes	
Operation Temperature	0 to 40°C	
Storage Environment	-20 to 70°C	
Operation Humidity(*9)	0 to 95% RH	
EMC & Safety	CE & LVD	
Dimension(HxWxD)	1000(with casters)x704x910 mm / 39.37x27.72x35.83 inch	
Weight	520kg / 1146.4 lbs	

- *1 Power factor is tested on input voltage 400Vac with full output power
- *2 Maximum distortion is tested on output voltage 350Vac with full output power under linear load
- *3 Load regulation is tested by sine wave and remote sense
- *4 At working voltage 150V
- *5 When the output voltage is greater than 40V
- *6 Current total harmonic distortion is tested on input voltage 400Vac with full output power
- *7 Power factor is tested on input voltage 400Vac with full output power
- *8 Efficiency is tested on input voltage 400ac and output voltage 250Vac with full output power under linear load
- *9 In the state of non-condensing
- *10 Refer to the following voltage/current operating range charts for the output capability of the Regenerative Grid Simulator.

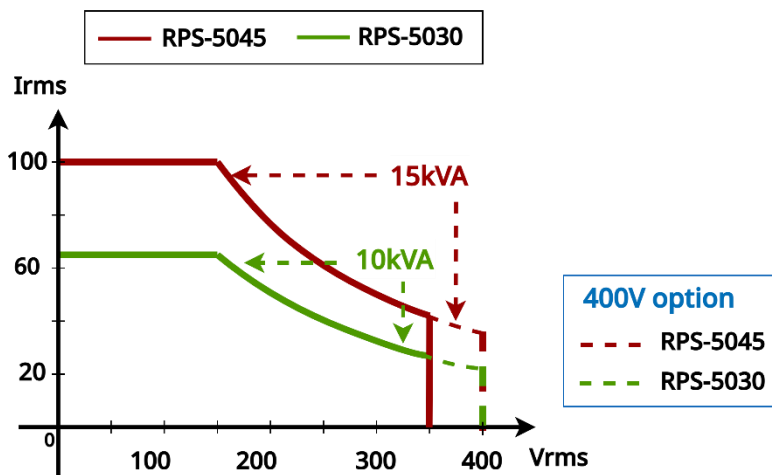

Figure 1-1 AC Voltage/Current Operating Range – Three-Phase Mode

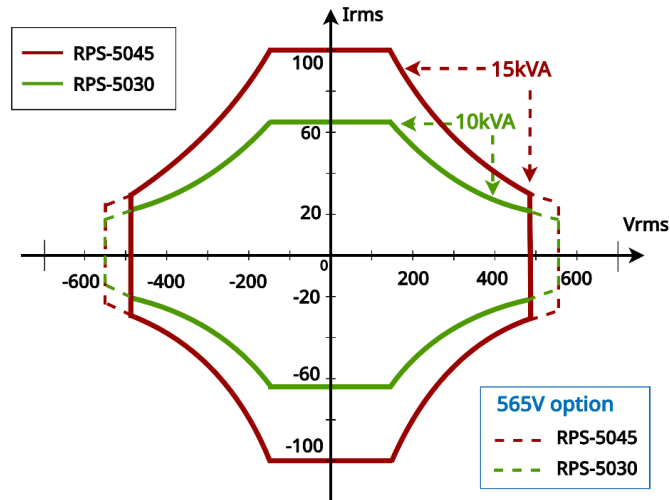

Figure 1-2 DC Voltage/Current Operating Range – Three-Phase Mode

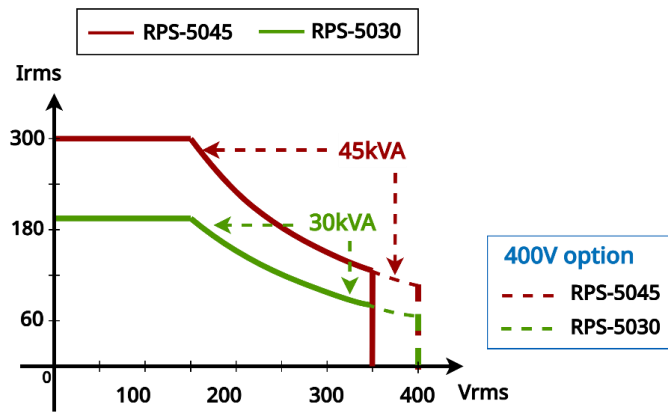

Figure 1-3 AC Voltage/Current Operating Range – Single-Phase Mode

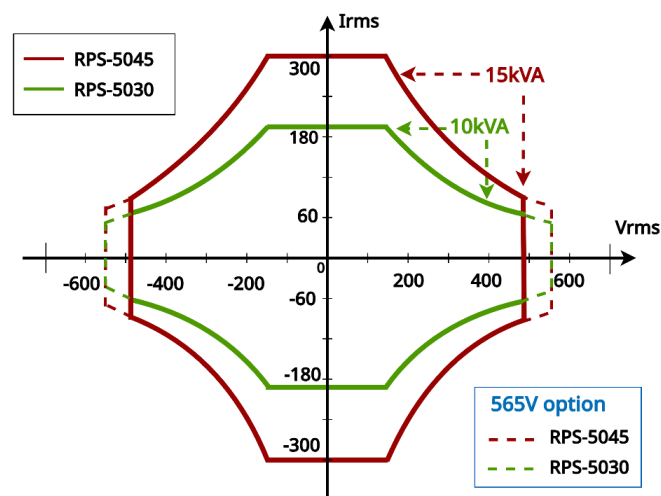





Figure 1-4 DC Voltage/Current Operating Range – Single-Phase Mode



2 Device Introduction

2.1 Unboxing Inspection

This cabinet-type product is shipped in wooden packaging. Please follow the included unboxing instructions to unpack the unit. After unsealing the instrument, check the machine's appearance for any signs of deformation, scratches, or panel damage, and retain the original packaging materials. If any damage is found, please file a claim with the shipping carrier immediately. Before returning the product, contact INFINIPOWER or the designated distributor. Do not return the product directly to INFINIPOWER without prior approval.

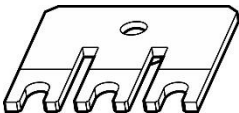
After unboxing, before operating the instrument, check the contents of the package and related accessories. If any discrepancies, missing items, or damages are found, please contact an authorized INFINIPOWER distributor or after-sales service department immediately. The packaging includes the following items:

Item	Name	Quantity	Description
	RPS-5000 Regenerative Power System	1	For the specific models included in this series, please refer to section 1.3 Model List
	USB Cable (Type B, 1.5 meters)	1	USB communication cable; allows users to connect external devices to the USB port on the rear panel of the RPS-5000 for communication and data transfer
	Ethernet Cable (1.5 meters)	1	Network communication cable; allows users to connect external devices to the network port on the rear panel of the RPS-5000 for communication and data transfer
	DB25 Adapter Board	1	External interface adapter board for the rear panel of the RPS-5000, used for signal measurement
	Output Shorting Adapter	1	Copper busbar used as a fixture for single-phase mode

	Black Rotating Plugs	4	Used to cover and flatten the lifting ring holes on top of the RPS-5000
	Test Report	1	Factory test report of the equipment before delivery
	Certificate of Compliance	1	Calibration compliance certificate

2.2 Dimensions

The instrument should be installed in a well-ventilated environment with adequate space. Please refer to the following dimension information to select a suitable installation space.

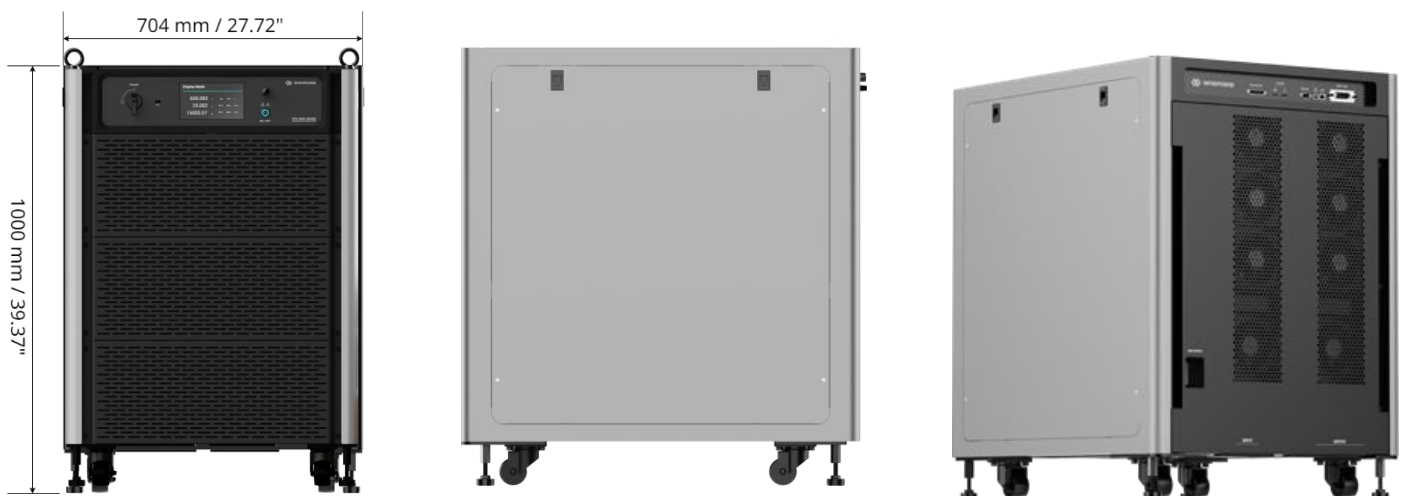

CAUTION

- The load on the top cover of the equipment must not exceed 50 kg. exceeding this limit may cause deformation or damage to the cover and affect the safety of the equipment.

2.3 Transportation

As this is a cabinet-type product with considerable weight, please observe the following precautions to ensure both equipment and personnel safety when moving the unit after unboxing.

CAUTION

- Cabinet-type products are heavy. Before moving or installing the unit, ensure the floor is level and capable of bearing the maximum weight.
- Do not move the machine on slopes, uneven surfaces, or roads with bumps or potholes to prevent tipping caused by a shifted center of gravity.
- During transportation, always confirm the floor is level. It is recommended to have two or more people move the unit slowly, or to use a dolly with the specifications shown below: length B > 1200 mm; length A1 between 600 mm and 750 mm. Refer to the transport diagram (Figure 1-5). The dolly must support more than 1000 kg, and the forks must extend beyond the cabinet. Ensure that area A on both sides is equal to maintain proper balance.
- The RPS-5000 series is equipped with lifting rings on the top. It is recommended to use a crane with a four-point lifting hook for horizontal hoisting. The crane must have a lifting capacity of more than 1000 kg, and all four lifting straps must be of equal length to prevent tilting during movement (as shown in Figure 1-6).
- Once moved into position, lock the four leveling feet at the bottom to secure the unit.
- During transportation and operation, the equipment must remain level. Do not tilt or place it on sloped surfaces to avoid potential damage.
- The equipment itself weighs 550 kg. When moving it with wheels, the maximum allowable total weight (including the equipment and any additional load) is 850 kg. Do not place additional items exceeding this limit during movement to prevent wheel damage or equipment tipping.

- When the equipment is fixed with foot pads, the maximum allowable total weight is 1000 kg (including the equipment and any additional load). Do not apply extra pressure or place items exceeding this weight while stationary to avoid structural damage or imbalance.

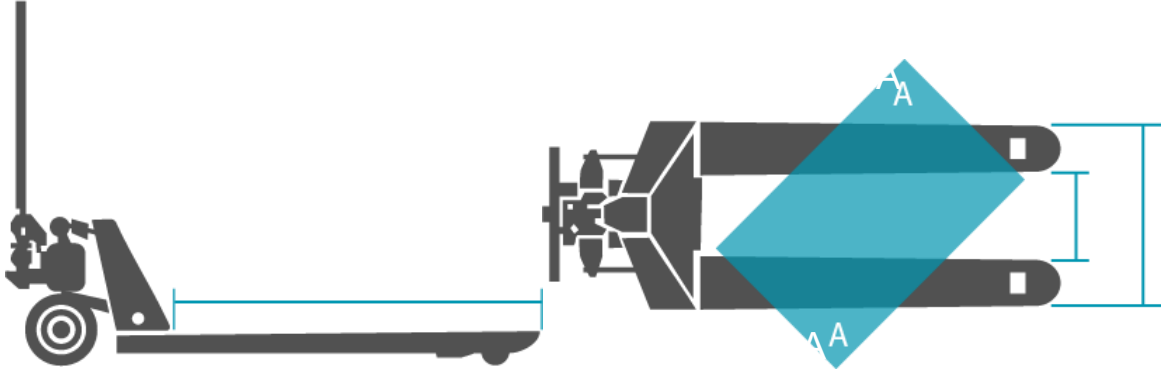

Figure 2-1 Dolly Transport Method Diagram

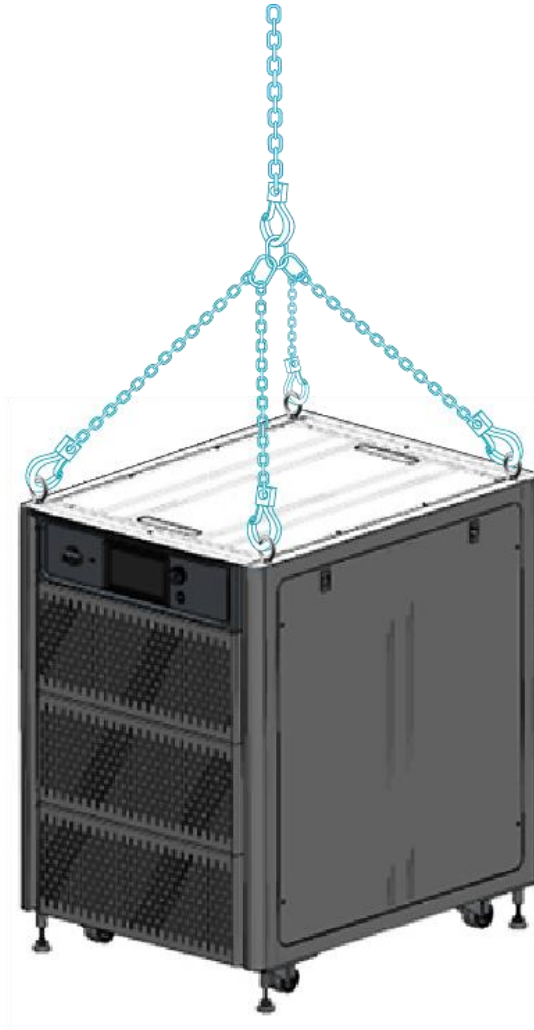









Figure 2-2 Crane Transport Method with Four-Point Lifting Hooks Diagram

2.4 Function Key Description

2.4.1 Front Panel



Item	Illustration	Description
1		Lifting Ring: Used for transporting and installing the equipment.
2		Main Power Switch: Turns the power on or off.
3		USB (HOST): Used for screen display, data capture, and firmware updates.
4		LCD Touchscreen: 7" LCD display for input/output settings and measurement values.
5		Output ON/OFF Button: Toggles power output. LED on indicates OUTPUT ON; LED off indicates OUTPUT OFF.
6		Rotary Knob: Scroll to browse and select values. Used for real-time adjustment of parameters such as output voltage and frequency. Pressing confirms selection (ENTER function).

7		Leveling Foot Pad: Provides stable support and allows for securing the unit in place.
8		Lockable Caster: Supports the unit and allows for mobility when needed.

WARNING





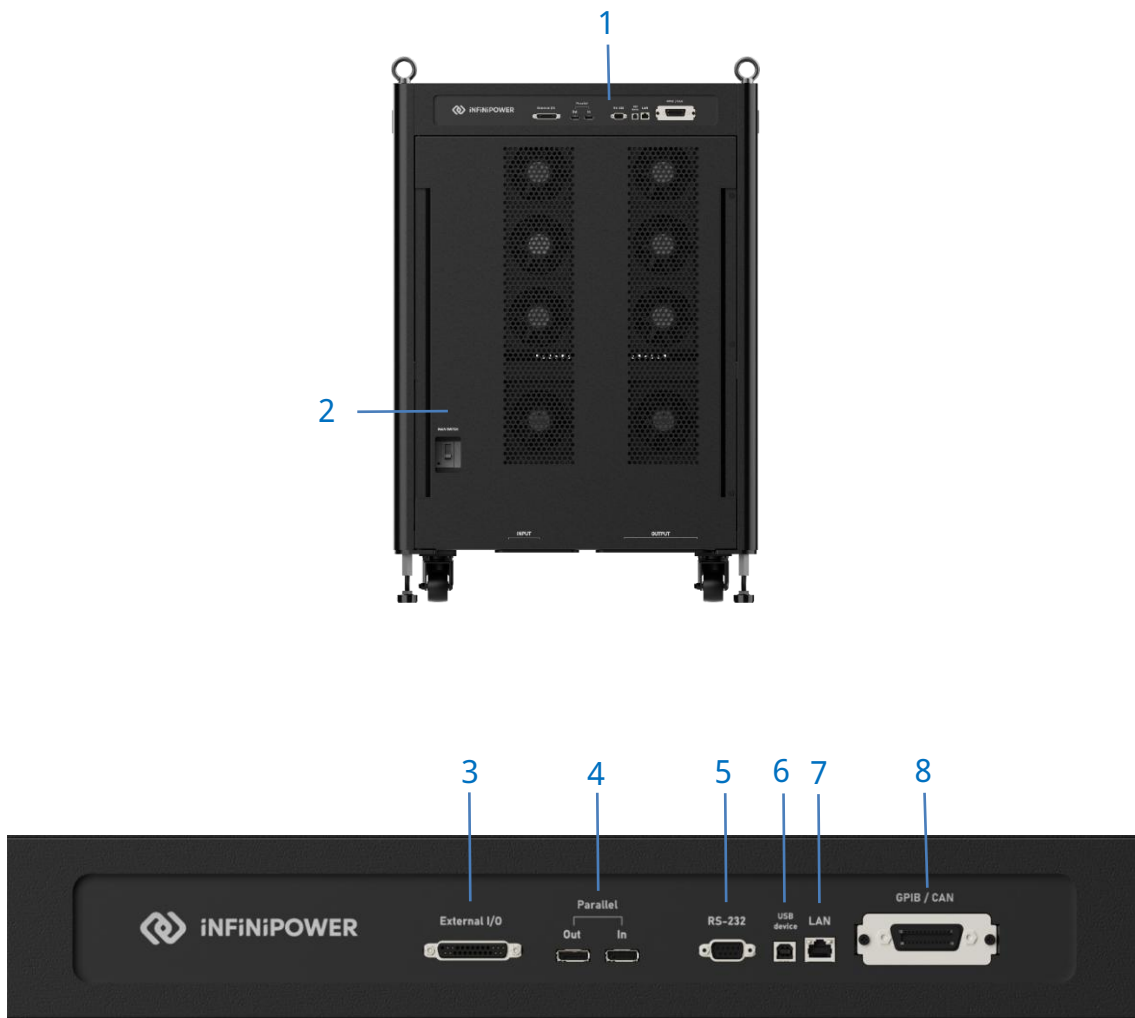

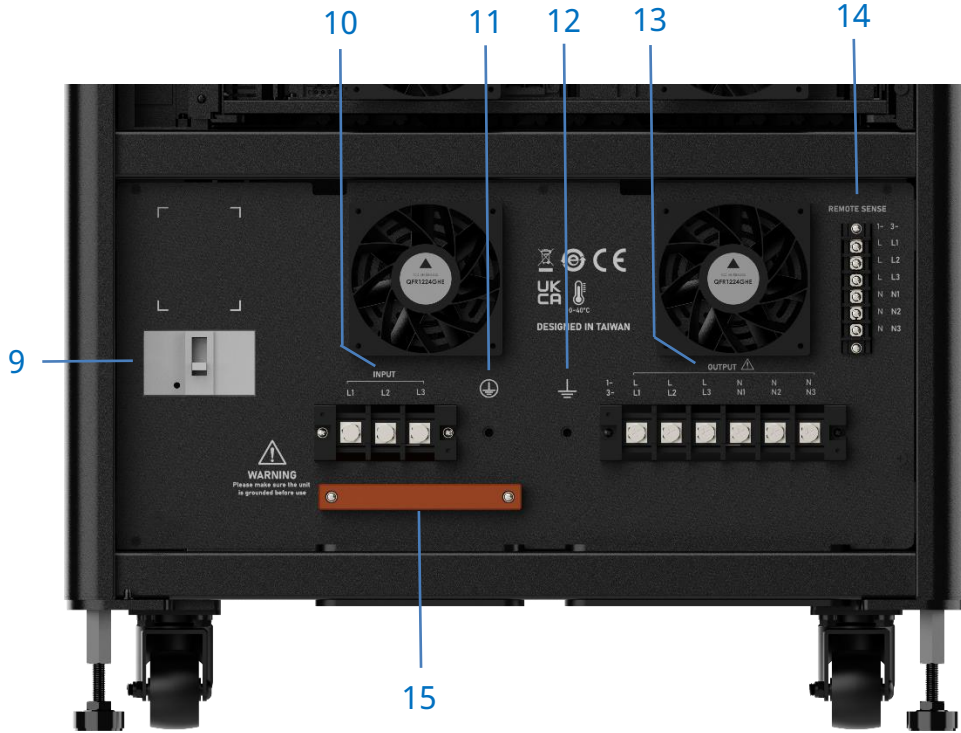

- The USB HOST port on the front panel is intended for USB flash drives only. Do not connect power banks or other electronic devices, as this may cause damage to the equipment.

2.4.2 Rear Panel





Item	Illustration	Description
1		Rear Panel Control Interfaces: Includes External I/O, parallel connection , RS-232, USB, Ethernet, and optional GPIB/CAN.
2		Rear Panel: When opened, contains the three-phase power module, input circuit breaker (non-fuse type), input and output power terminals, remote sensing terminals, cooling fans, etc.
3		External I/O: External analog control interface (Ext.V), V/IMON monitoring signals, and other I/O control signals (AC_ON, FAULT-OUT, Ext-ONOFF, etc.).
4		Parallel Connection Interface: Used for communication between units during parallel output operation.
5		RS-232 : 9-pin D-sub female connector for RS-232 interface. Enables data transmission and remote control via computer.
6		USB : USB Type-B connector for data transmission and remote control via computer.

7		LAN : Ethernet (LAN) control interface for data transmission and remote control via computer.
8		Optional GPIB/CAN Interface Card: GPIB/CAN interface for data transmission and remote control via computer.
9		Input Circuit Breaker (Non-Fuse Type): Provides circuit protection against overload and short circuits. Quickly disconnects the circuit when current exceeds the rated value, protecting the equipment.
10		Power Input Terminal: Connects to the three-phase power supply to power on the unit.
11		Protective Earth Terminal: Grounding terminal for the chassis to ensure equipment safety and regulatory compliance.
12		Functional Ground Terminal: Terminal for connecting the device to the DUT chassis to ensure proper function and performance stability.
13		Power Output Terminal: AC and DC output terminals for connecting to the device under test (DUT).
14		Remote Sensing Terminal: Used for remote voltage sensing to compensate for voltage drops caused by load cables. Terminal L1 should connect to the L1 point of the DUT, while N1/N2/N3 should connect to the N point of the DUT.
15		Power Input Cable Clamp: Used to secure the three-phase input power cable (including ground wire).

3 Installation

3.1 Environmental Conditions

This equipment is intended for indoor use only. The table below lists the specific environmental requirements for the device.

Parameter	Specification
Operating Temperature	0°C to 40°C (32°F to 104°F)
Storage Temperature	-20°C to 70°C (-4°F to 158°F)
Altitude	Up to 2000 meters (6560 feet)
Relative Humidity	0% to 95% (non-condensing)
Overvoltage Category	CAT II
Pollution Degree	II

WARNING

- Ensure that the air intake is not blocked while operating the equipment. Obstruction may cause overheating and damage internal components.

NOTICE

- To ensure measurement accuracy, it is recommended to warm up the instrument for 30 minutes before use.

3.2 Maintenance and Care

To ensure proper operation and extend the service life of the regenerative power system, please follow the maintenance and cleaning guidelines below:

1. Regular Inspection and Maintenance

- Periodically check cables, connectors, and connection points for looseness, wear, or damage.
- Ensure all cooling fans and ventilation openings are clean and free from dust or debris.

- It is recommended to inspect internal components annually. The maintenance cycle can be adjusted depending on the environment. For service, please consult local professional technical support.
- The regenerative power system and related accessories should be tested and calibrated annually to ensure user safety and measurement accuracy..

2. Cleaning Procedure

- Power off before cleaning: Always disconnect all power sources before cleaning the device to ensure it is powered off.
- External cleaning: Use a soft dry cloth or a slightly damp cloth to gently wipe the exterior of the device. Avoid using solvents or corrosive chemicals to prevent damage to the casing or labels.
- Ventilation cleaning: Periodically clean dust from the ventilation openings and fans using a can of compressed air or a low-pressure blower to maintain smooth airflow and prevent overheating.

3. Precautions

- Do not allow liquids to enter the device, as this may cause short circuits or damage internal components.
- Do not use sharp objects to scratch the casing to avoid surface damage.
- If the device will not be used for an extended period, store it in a dry, ventilated environment to prevent moisture and excessive heat.

CAUTION

- For internal components or complex malfunctions, please contact local professional technical support. Do not attempt to disassemble or repair the equipment yourself to avoid damage. If unauthorized parts are found to be used, the warranty will be void, and INFINIPOWER will not be responsible for any repairs or damages caused by unauthorized servicing.

3.3 Input Power Specifications

3.3.1 Rated Values

Model	RPS-5030	RPS-5045
AC Input		

Phase	3Ø3W	
Voltage	200 - 220 VL-L ± 10% 380 - 400 VL-L ± 10% 440 - 480 VL-L ± 10%	
Frequency	47 - 63Hz	
Max. Current	124A/phase (200 - 220 VL-L ± 10%) 66A/phase (380 - 400 VL-L ± 10%) 58A/phase (440 - 480 VL-L ± 10%)	186A/phase (200 - 220 VL-L ± 10%) 99A/phase (380 - 400 VL-L ± 10%) 87A/phase (440 - 480 VL-L ± 10%)

- The input voltage is based on three-phase AC line-to-line voltage (VL-L).
- The RPS-5000 series offers three different input voltage ranges. Users must confirm the appropriate three-phase AC voltage specification before purchase.

WARNING

- Before wiring, ensure the supply voltage matches the equipment specifications. If the input voltage exceeds the rated input of the regenerative power system, it may cause damage.

3.3.2 Input Wiring

Table 3-1 lists the standard input power cable specifications, rated at 600V and 105°C. The selected cable must have a voltage and current rating equal to or greater than the rated current of the regenerative power system. The input terminal block is located on the lower left side of the rear panel. Please follow the steps below as shown in Figure 3-1:

1. Open the rear panel of the regenerative power system.
2. Loosen the screws on the safety clamp below the INPUT terminals.
3. Route the three-phase input power cable through the bottom hole of the rear panel and the safety clamp, then connect it to the INPUT terminals of the regenerative power system and tighten the screws, as shown in Figure 3-1.
4. Secure the power cable using the safety clamp and tighten the screws.
5. Close the rear panel of the regenerative power system.

WARNING

- Power cable installation must be performed by qualified personnel and in accordance with local electrical regulations.
- Before connecting the power cable, ensure the power switch is turned off and that there is no hazardous voltage at the terminal connections.
- Connect the input ground wire to the GND  terminal, and ensure the other end is connected to a properly grounded AC distribution panel. Do not operate the regenerative power system without proper grounding.

NOTICE

- To prevent excessive contact resistance caused by insufficient fastening force on the input/output wiring, it is recommended to torque M8 screws to 65 kgf-cm.

Table 3-1 Input Power Cable Specification Configuration Table

Operating Voltage Range	Cable Specification	Terminal Specification
200 - 220 VL-L \pm 10%	60mm ² (L1/L2/L3) 22mm ² (GND)	60-8 (L1/L2/L3/N1/N2/N3) 22-8 (GND)
380 - 400 VL-L \pm 10%	38mm ² (L1/L2/L3) 14mm ² (GND)	38-8 (L1/L2/L3/N1/N2/N3) 14-8 (GND)
440 - 480 VL-L \pm 10%	38mm ² (L1/L2/L3) 14mm ² (GND)	38-8 (L1/L2/L3/N1/N2/N3) 14-8 (GND)

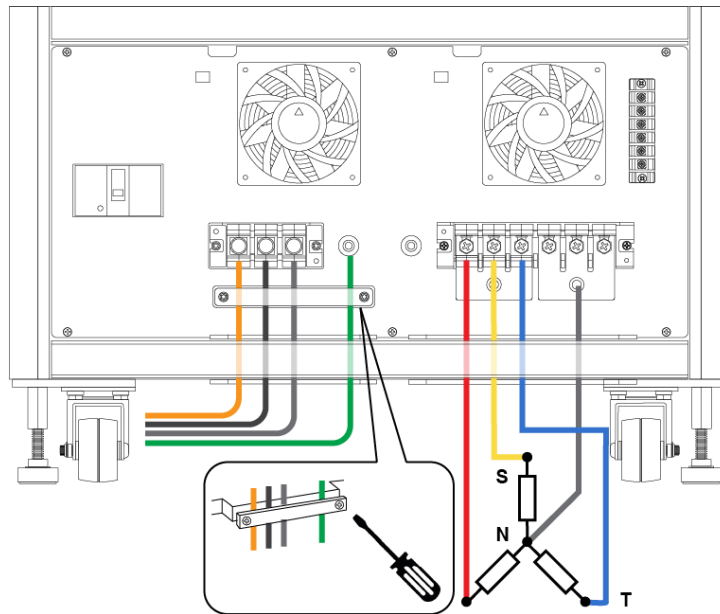

Figure 3-1 Three-Phase Input Power Wiring and Cable Securing Method

3.4 Output Wiring

As output cables are not included by default, please refer to Table 3-2 for the maximum current values per model and select cables rated at 600V, 105°C that meet the required current rating. The output terminal block is located on the lower right side of the rear panel. Connect the load to the OUTPUT terminals. You may route the output cables through the bottom hole and then connect them to the OUTPUT terminals. After ensuring the cables are securely fastened to the terminals, close the rear panel of the regenerative power system. Refer to Figure 3-2.

WARNING

- Before connecting output cables, ensure the regenerative power system is powered off and confirm there is no hazardous voltage at the terminal area to prevent electric shock and injury.
- If multiple DUTs (devices under test) are connected to the output, ensure each test cable can handle the full rated output current of the regenerative power system. Cables must not overheat during load testing.

Table 3-2 Output Current and Recommended Cable Specification Table

Model	Maximum Output Current	Recommended Cable Specification
RPS-5030	66.7A(Three-Phase / Split-Phase Mode)	22mm ² (L1/L2/L3/N1/N2/N3)
	200A(Single-Phase Mode)	80mm ² (L/N)
RPS-5045	100A(Three-Phase / Split-Phase Mode)	38mm ² (L1/L2/L3/N1/N2/N3)
	300A(Single-Phase Mode)	150mm ² (L/N)

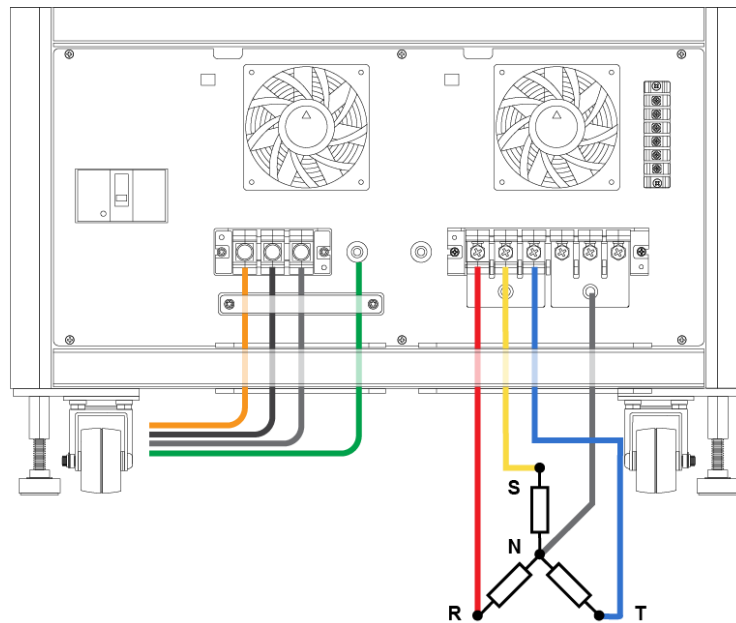

Figure 3-2 Output Power Cable Wiring Method

3.4.1 Connecting the DUT (Local Sensing)

This device supports two wiring methods for connecting to the Device Under Test (DUT): Local Sense and Remote Sense.

By default, the system operates in Local Sense mode, with the Remote Sense function disabled.

NOTICE

- Ensure that the Remote Sense function is turned OFF in the System settings on the panel. Otherwise, the following wiring method may trigger an alarm on the regenerative power system.

- In three-phase or single-phase mode, when the output contains a DC voltage component, the output terminal "L" is the positive (+) pole, and "N" is the negative (-) pole.
- In split-phase mode, when the output contains a DC voltage component, the output terminal "L1" is the positive (+) pole, and "L2" is the negative (-) pole.
- When switching the regenerative power system to single-phase mode, use the standard shorting fixture to connect the output terminals L1/L2/L3. Then, connect the DUT's L and N terminals respectively to the shorted L1/L2/L3 and N1/N2/N3 terminals on the fixture. The DUT's ground terminal may be connected to the GND terminal on the unit, as shown in Figure 2-4.

When the regenerative power system is operating in three-phase mode, the output connection method is as shown below:

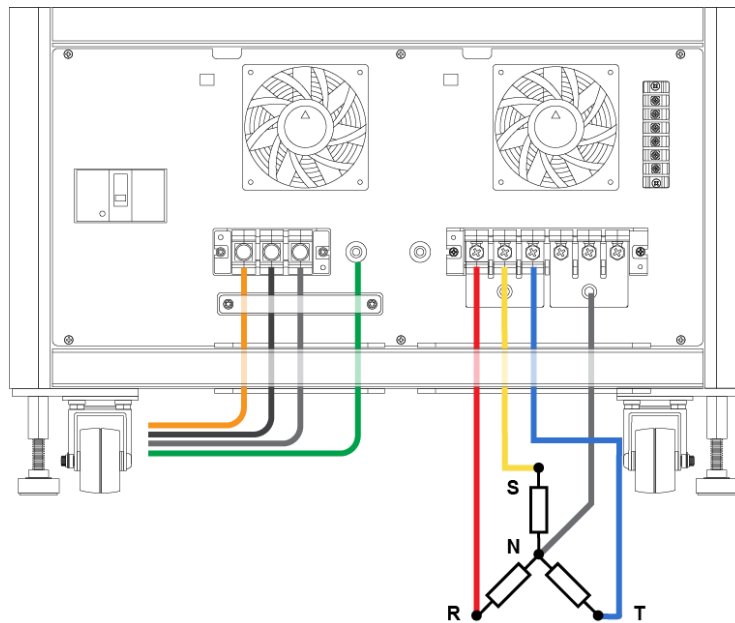

Figure 3-3 Three-Phase Output Wiring Method

When the regenerative power system is operating in single-phase mode, the output connection method is as shown below:

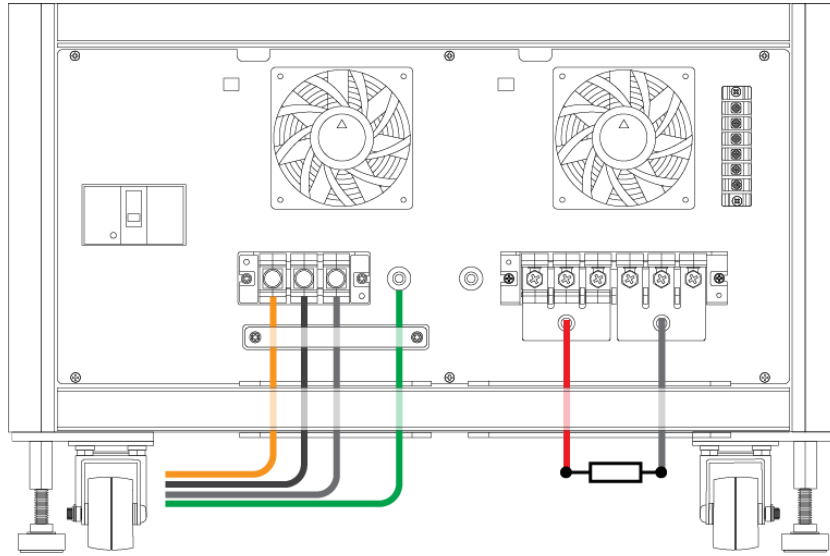

Figure 3-4 Single-Phase Output Wiring Method

When the regenerative power system is operating in split-phase mode, the output connection method is as shown below:

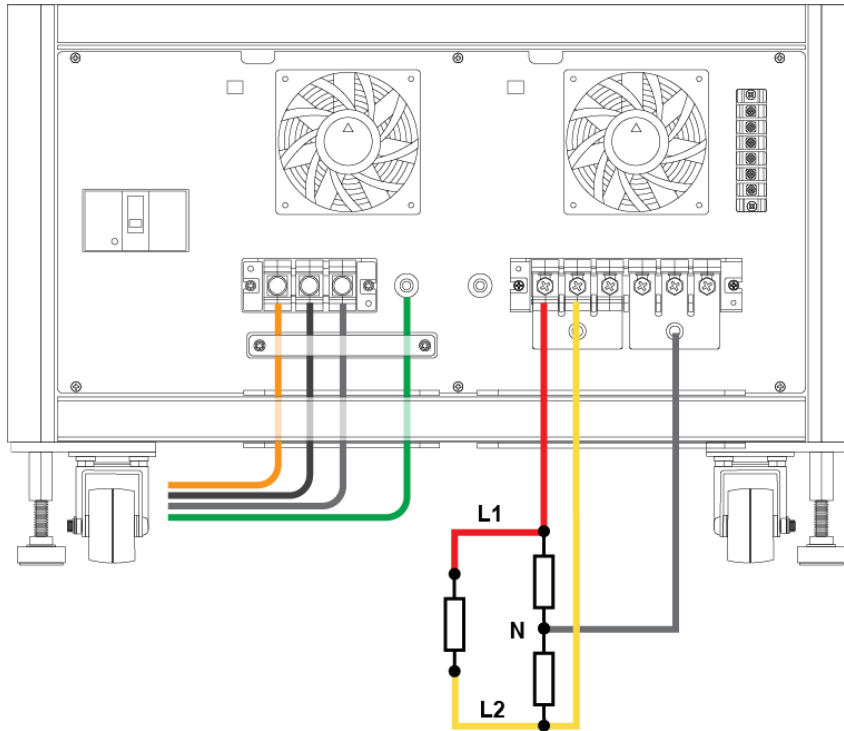

Figure 3-5 Split-Phase Output Wiring Method

3.4.1 Connecting the DUT (Remote Sensing)

Remote Sense allows for voltage measurement at the load end. When the cable between the regenerative power system and the DUT is long or has high impedance, it can cause a significant voltage drop across the connection. To ensure measurement accuracy, the device provides a Remote Sense terminal on the rear panel to automatically compensate the voltage drop and maintain the user-set voltage at the load.

Before testing, secure the remote sense wires to the Remote Sense terminals on the rear panel of the regenerative power system. Connect the other ends to the corresponding terminals on the DUT, and ensure all connections are firmly fastened.

Before starting the output test, go to the main menu, navigate to System, and set Remote Sense to ON.

NOTICE

- Remote sense cables should be multi-stranded wires rated at 600V, 105°C. It is recommended to use 18 AWG or thicker to ensure low impedance. When connecting, place the wires as close to the load as possible and twist the sense wires together to minimize external voltage interference.

When the regenerative power system is operating in three-phase mode, the output and remote sense wiring method is as shown below:

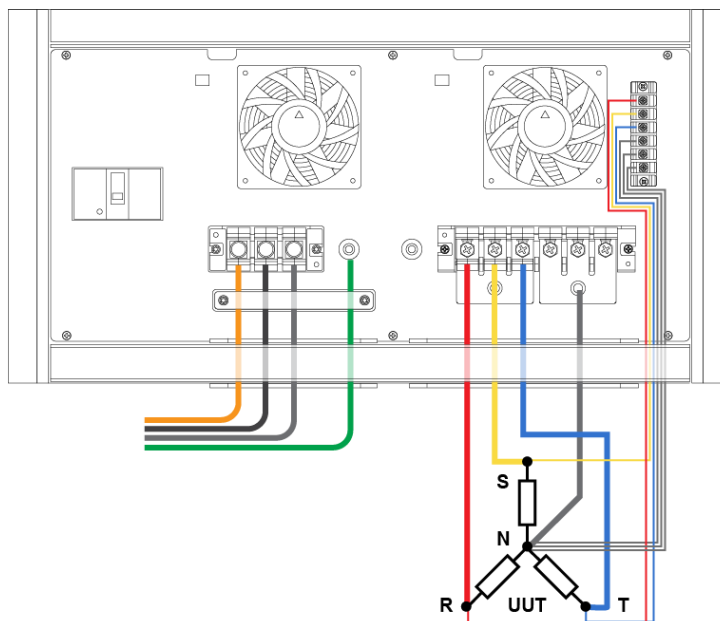

Figure 3-6 Three-Phase Mode Output and Remote Sense Wiring Method

When the regenerative power system is operating in single-phase mode, the output and remote sense wiring method is as shown below:

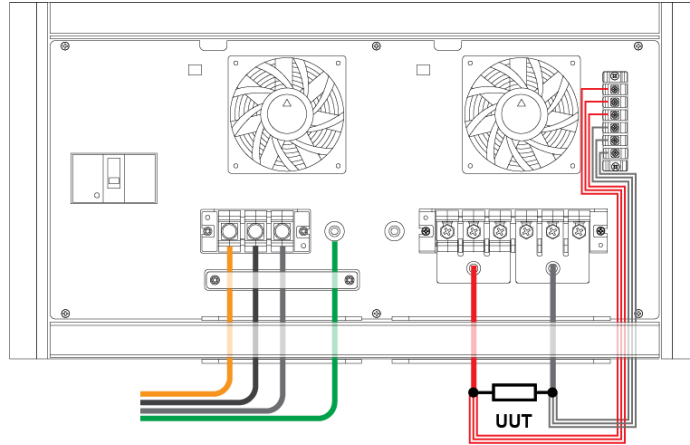

Figure 3-7 Single-Phase Mode Output and Remote Sense Wiring Method

When the regenerative power system is operating in split-phase mode, the output and remote sense wiring method is as shown below:

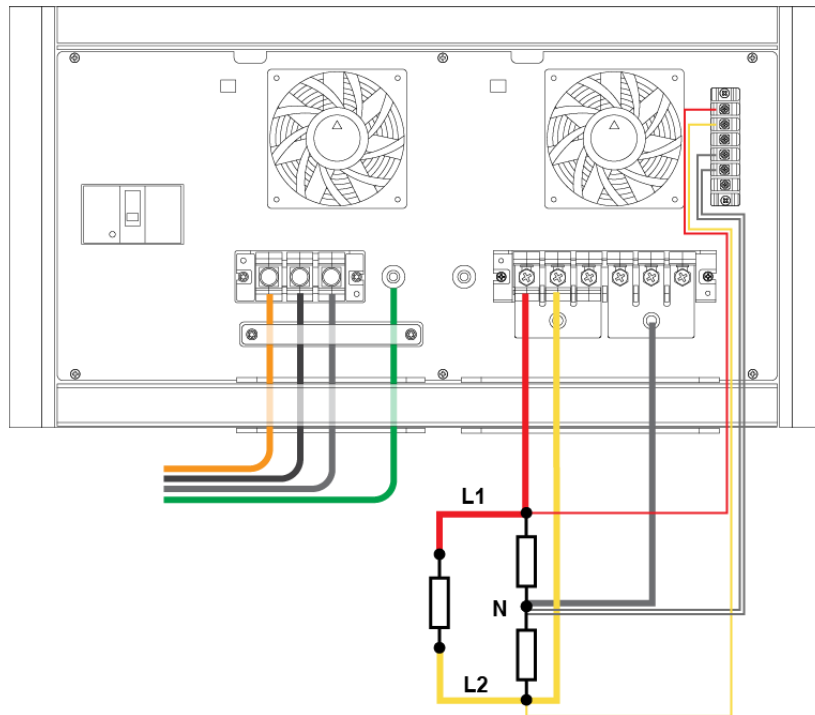

Figure 3-8 Split-Phase Mode Output and Remote Sense Wiring Method

4 Operation Instructions

4.1 Power-On Procedure

CAUTION

- Before powering on the unit, ensure that all protective earth terminals, extension cords, and connected devices are properly grounded. Any interruption of the protective grounding may pose a risk of electric shock and potential injury.

Once the input power cable is connected, switch the rear panel input circuit breaker upward to the ON position. Then, rotate the main power switch on the lower left corner of the front panel 90 degrees clockwise to turn on the unit. The regenerative power system will begin a series of self-checks, and the front panel touchscreen will light up, displaying the following screen:

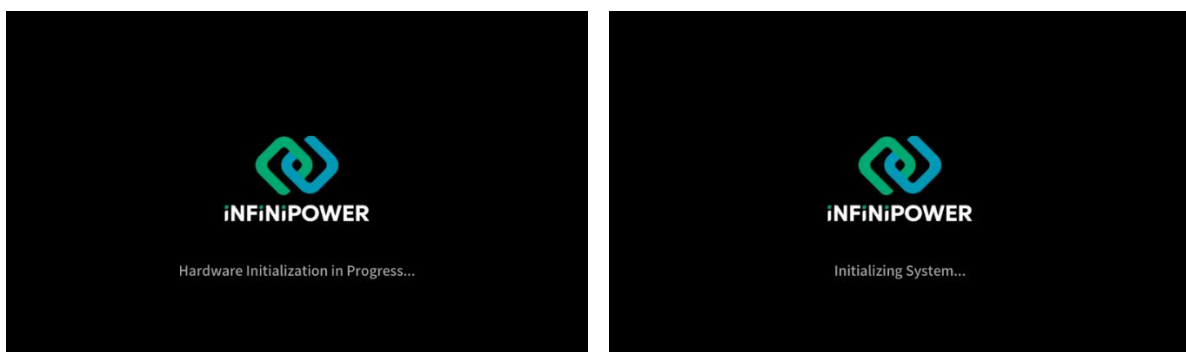

Figure 4-1 RPS-5000 Series Startup Initialization Screen

During startup, the regenerative power system performs internal data and communication self-diagnostics. Once completed, the system will activate the power module and run a self-power-on test to ensure proper operation. After passing the test, the system will enter the standby main screen.

NOTICE

- The full startup and self-check process for the regenerative power system takes approximately 30 seconds.

4.2 Main Screen Overview

After the user powers on the RPS-5000 Series Regenerative Power System and the self-check process is completed, the default main screen will be displayed, as shown in Figure 4-2. This is an overview of the main screen’s functional areas. The system can operate in three-phase, single-phase, or split-phase mode. The main screen layout will vary slightly depending on the selected mode at startup.

■ Standby Main Screen Functional Area Description

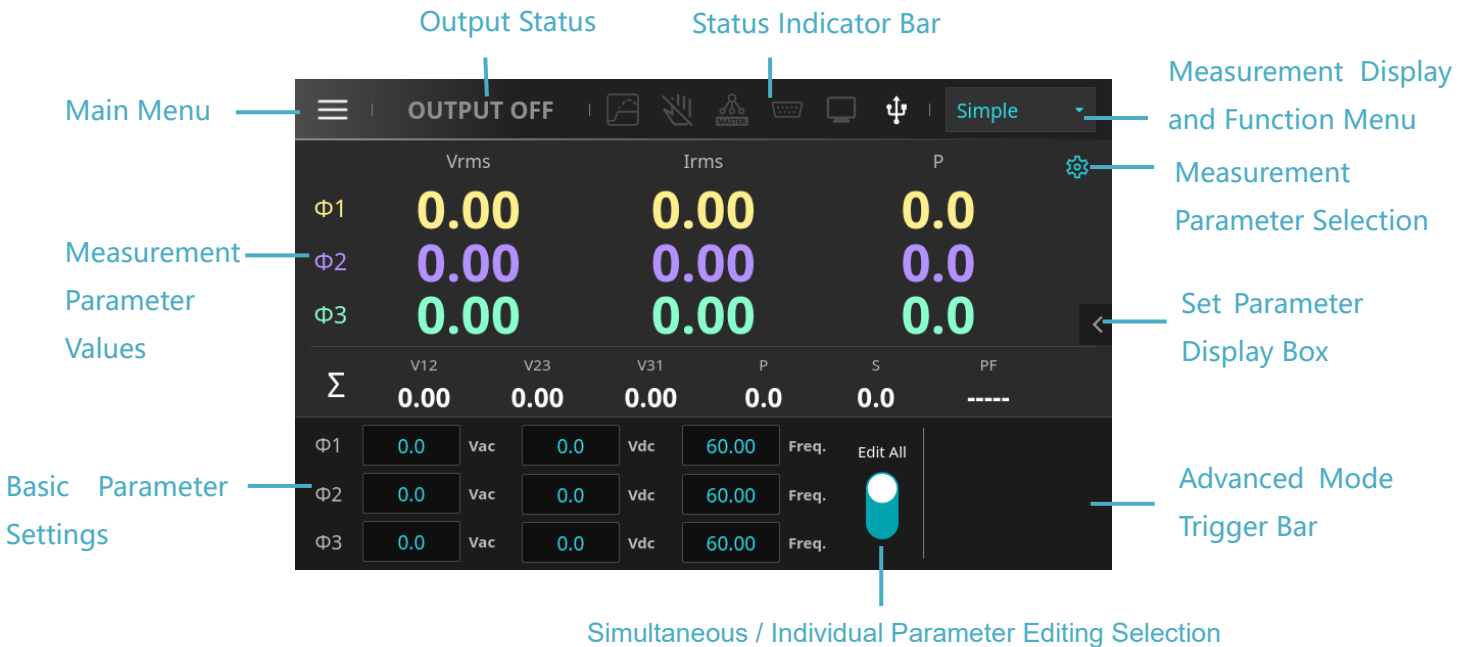

Figure 4-2 Three-Phase Mode Standby Main Screen (Simple Mode Page)

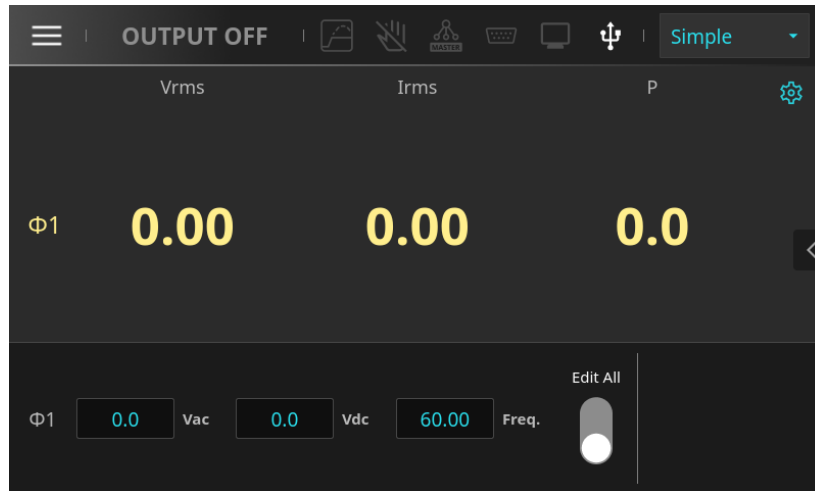

Figure 4-3 Single-Phase Mode Standby Main Screen (Simple Mode Page)

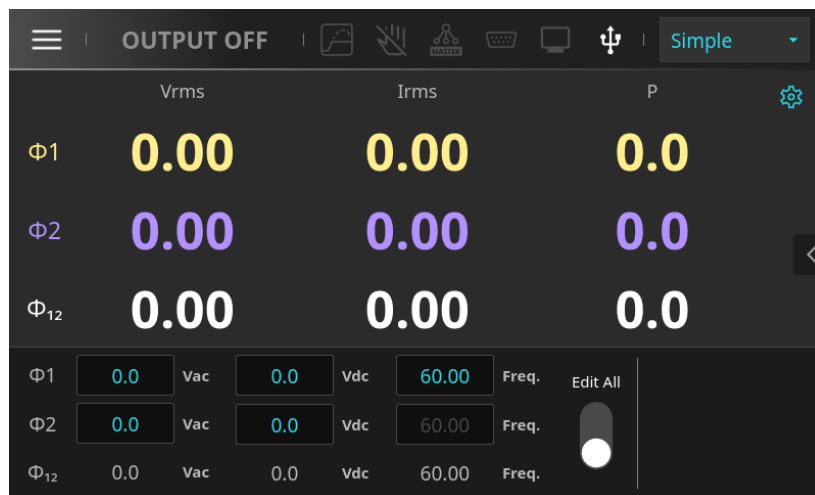



Figure 4-4 Split-Phase Mode Standby Main Screen (Simple Mode Page)

■ Status Indicator Bar Description

Item	Description
	When the Current Limit Control or Power Limit Control function is enabled, and the output reaches the current or power limit setting, this icon's white border will light up.
	When the screen lock function is enabled, the front panel touchscreen becomes non-operational, and this icon's white border will light up.
	When the Parallel Control function is enabled, indicating the unit is operating in multi-unit parallel mode, this icon's white border will light up.
	When the External Output ON/OFF function is enabled, the front panel OUTPUT ON/OFF button becomes disabled, and output control is managed via External Interface pin 18. This icon's white border will light up.

	When the device is operating in remote mode, this icon's white border will light up.
	When a USB flash drive is inserted into the front panel USB (Host) port, and is successfully recognized by the system, this icon's white border will light up.

The regenerative power system can be operated in either manual or remote mode. In remote operation mode, control can be carried out via USB/LAN interfaces or other ports; for detailed instructions, please refer to Chapter 11. This chapter introduces manual operation, where parameters are entered and tests conducted using the front panel's touchscreen and rotary knob. For the command tree, please refer to Table 4-1.

Table 4-1 User Interface Tree Structure

Home Screen		
Item	Sub-item	Description
Measurement Display & Function Menu	Detail	Displays all measurement parameter values in the Detail view.
	Simple	Displays the Simple view, allowing selection of three measurement values.
	Harmonic	Displays the Harmonic view with harmonic analysis table and bar graph.
	Wave	Displays voltage and current waveforms for three-phase power.
Basic Parameter Settings		Set basic output voltage and frequency.
Advanced Mode Trigger Bar		Used to trigger output in advanced mode.
Output Status		Indicates the current output status: 1. OUTPUT ON (green text) when output is active 2. OUTPUT OFF (gray text) when output is off or in a selected advanced mode 3. ALARM (red text) when protection is triggered
Status Indicator Bar		Displays current system statuses including: current limit, screen lock, parallel mode, external control, remote mode, USB usage, etc.

Set Parameter Display Box		Displays currently set parameters for the selected mode, including voltage, frequency, etc.
Simultaneous / Individual Parameter Editing		When “Edit All” is enabled, parameters of the same type in three-phase/split-phase mode can be edited simultaneously.
Measurement Parameter Selection		In Simple mode, users can select three measurement values to display.
Main Menu		Enter the main menu page.
Main Menu		
Item	Sub-item	Description
Mode Settings		Enter the mode settings page.
Output Settings		Enter the output settings page.
System Settings		Enter the system settings page.
Waveform Selection		Enter the waveform selection page.
Protection Settings		Enter the protection settings page.
Save/Load		Enter the save/load page.
Device Info		Enter the device information page.
Mode Settings		
Item	Sub-item	Description
Basic Mode Settings		Set basic output voltage and frequency.
Mode Selection		Choose the current output mode.
Advanced Mode Settings	List Mode Parameter Editing	List Mode
	Step Mode Parameter Editing	Step Mode
	Pulse Mode Parameter Editing	Pulse Mode
	Synthesis Mode Parameter Editing	Synthesis Mode
	Inter-Harmonic Mode Parameter Editing	Inter-Harmonic Mode
	Transient Mode Parameter Editing	Transient Mode
Output Settings		
Item	Sub-item	Description

Output Phase		Switch between different output phase modes
Source Mode		Select advanced simulation or operation modes
Phase	Active Phases	Displays currently active output phases
	3 Φ Sequence	Set the phase sequence in three-phase mode
	Phase Angle 1-2	Phase difference between L1 and L2
	Phase Angle 1-3	Phase difference between L1 and L3
	3 Φ Phase Mode	Set the relationship between output voltages in three-phase mode
	Independent Relock	Phase re-lock function in three-phase mode
	Balance V Format	Voltage configuration format selection in balanced three-phase mode
Output	Coupling	Output mode configuration
	Output Relay	Output relay setting
	Immediately Start	Output voltage starts at any angle
	Start Angle	Starting angle of output voltage
	Measure Time	Number of times measurement values are averaged
	Immediately End	Output voltage stops at any angle
	End Angle	Ending angle of output voltage
	Response Setting	Output response speed setting
Slew Rate	Vac Slew Rate	Rise rate of AC output voltage
	Vac-off Slew Rate	Fall rate of AC output voltage when turned off
	Vdc Slew Rate	Rise rate of DC output voltage
	Vdc-off Slew Rate	Fall rate of DC output voltage when turned off
	Frequency Slew Rate	Rate of frequency change
I Surge	I-Surge Delay	Delay time for surge current measurement
	I-Surge Interval	Time interval for surge current measurement
Impedance	Output Impedance	Programmable output impedance
	Φ 1 Resistance	Resistance value of output impedance for Phase 1
	Φ 1 Inductance	Inductance value of output impedance for Phase 1
	Φ 2 Resistance	Resistance value of output impedance for Phase 2
	Φ 2 Inductance	Inductance value of output impedance for Phase 2
	Φ 3 Resistance	Resistance value of output impedance for Phase 3
	Φ 3 Inductance	Inductance value of output impedance for Phase 3

System Settings

Item	Description
------	-------------

Device Function		Regenerative power system mode switching (Power Supply Mode, Load Mode)
Remote Sense		Remote sensing function
Remote Inhibit		Remote sense compensation function
External Output ON/OFF		External signal control of output state
External V-Ref.		External voltage reference input function
V-Ref Method		External voltage reference coupling method
Ext. V/I Monitor		Output voltage/current monitoring function
Power On State		Output state setting
Parallel Connect		Parallel function setting
Parallel Position		Role configuration when multiple units are used in parallel
Vac Setting Limit		Output AC voltage setting limit
Vdc(+) Setting Limit		Positive DC voltage setting limit
Vdc(-) Setting Limit		Negative DC voltage setting limit
Freq Setting Limit		Output frequency setting limit
Display Brightness		Screen brightness adjustment
Buzzer Volume		Buzzer volume adjustment
Date		Date display
Time		Time display
Language		Language selection
Status Panel		System status monitoring interface
Stop Touch		Screen lock function
FACTORY DEFAULT		Restore factory settings function
INTERFACE	GPIB Address	Configure Communication Interface Options
	RS232 Baud Rate	
	LAN DHCP	
	LAN IP Address	
	LAN Mask	
	LAN Gateway	
	MAC	
CALIBRATION		Perform System Calibration
Waveform Selection		
Item	Sub-item	Description
SINE		Sine Wave
SQUA		Square Wave
TRIA		Triangle Wave
CSIN	Total Harmonic Distortion (THD)	Clipped Sine Wave

	Amplitude (AMP)	
DST		Built-in Harmonic Waveforms (30 sets)
USER		User-Defined Waveforms (30 sets)
Protection Settings		
Item	Sub-item	Description
OCP	OCP Φ 1	Output Overcurrent Protection
	OCP Φ 1 Delay	
	OCP Φ 2	
	OCP Φ 2 Delay	
	OCP Φ 3	
	OCP Φ 3 Delay	
OPP	OPP Φ 1	Output Overpower Protection
	OPP Φ 2	
	OPP Φ 3	
OVP	OVP-Peak Φ 1	Output Overvoltage Protection
	OVP-Peak Φ 2	
	OVP-Peak Φ 3	
Limit	Current Limit Control	Constant Current / Constant Power Output Function
	Current Limit Φ 1	
	Current Limit Φ 2	
	Current Limit Φ 3	
	Power Limit Control	
	Power Limit Φ 1	
	Power Limit Φ 2	
	Power Limit Φ 3	
Save / Load		
Item		Description
Save		Save System
Load		Load System
Device Information		
Item		Description
Device Information		Product Model (P/N), Product Serial Number (S/N)
System Firmware Version		
Configuration		
Output Voltage Option		

Output Option	Frequency		
Regenerative Option	Load		

4.3 Main Screen Operation

4.3.1 Parameter Setting and Test Execution

The RPS-5000 series is equipped with a touchscreen and rotary knob, providing users with an intuitive and convenient programming interface. Users can select and switch parameters by tapping or sliding on the screen or by using the rotary knob on the front panel.

Both voltage and frequency values of this equipment are programmable, allowing customers to set various parameters within specified ranges according to their requirements. Before conducting tests, users should connect the device's output terminals to the Device Under Test (DUT). After ensuring all necessary safety measures, set the voltage (Vac, Vdc) and frequency (Freq) parameters in the basic mode parameter settings on the front panel (refer to Figure 4-5). Press the front panel output key (ON/OFF) ; the blue indicator around the output key will illuminate, indicating the device is actively outputting. Real-time measurement values will be displayed on the main screen.

To terminate the test, press the output key (ON/OFF)  again. The blue indicator will turn off, and the output relay of the regenerative power system will disengage, ceasing voltage output. At this point, measurement values displayed on the front panel will reset to zero.

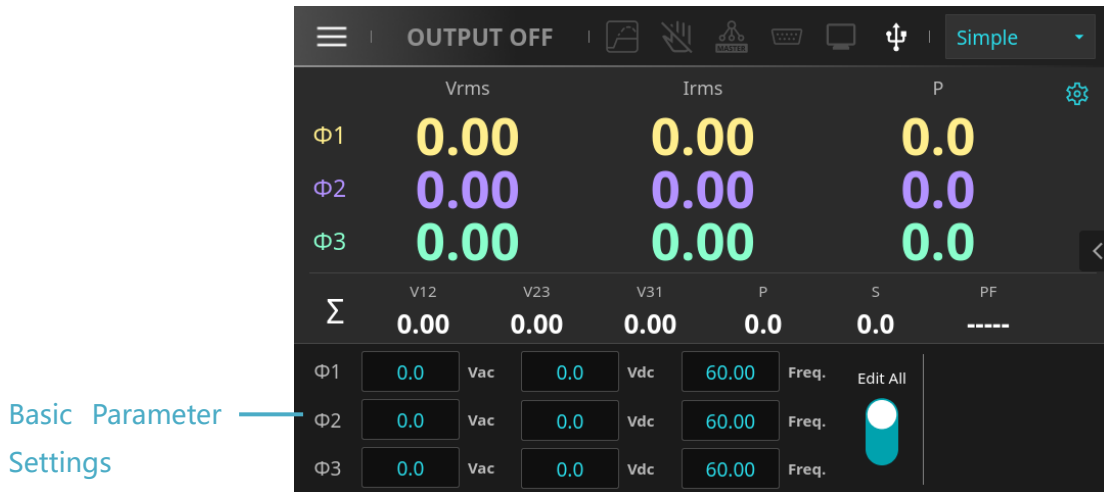

Figure 4-5 Basic Parameter Setting Fields in Three-Phase Mode

Output Setting Parameter Definition:

Parameter	Description
Vac	AC output voltage (Vrms), in Volt (V).
Vdc	DC output voltage (Vdc), in Volt (V).
Freq.	Output frequency, in Hertz (Hz).

WARNING

- The Output ON/OFF button is typically used to start or stop the equipment's output. This button remains effective even when the device is in remote mode or the touchscreen is locked.
- When the front panel Output ON/OFF button indicator is off and the device output is in the OFF state, it does not necessarily mean the device is free from electrical hazards. Dangerous voltages may still be present at the output terminals, posing a potential threat to personal safety. Before connecting test cables, be sure to read and comply with the safety precautions provided in Section 3.4 regarding output terminal wiring.

NOTICE

- When the Coupling is set to AC+DC, the output will be a combination of Vac and Vdc. The total peak voltage must not exceed 495 V. If this limit is exceeded, upon pressing the front panel Output (ON/OFF)



button, the device will output 0 V, and the screen will display an over-voltage protection (SET_OVP) message.

4.3.2 Numeric Keypad

On the main screen and other mode pages, if the setting values are displayed numerically, users can modify them by tapping the numeric display on the touchscreen. Tapping the numeric display will bring up the numeric keypad screen (as shown in Figure 4-6). After entering the desired values, press the enter button

Enter

to complete the settings. If you need to cancel the settings, press the cancel button

Cancel

or tap anywhere outside the numeric keypad area to return to the previous page. The setting range of the current

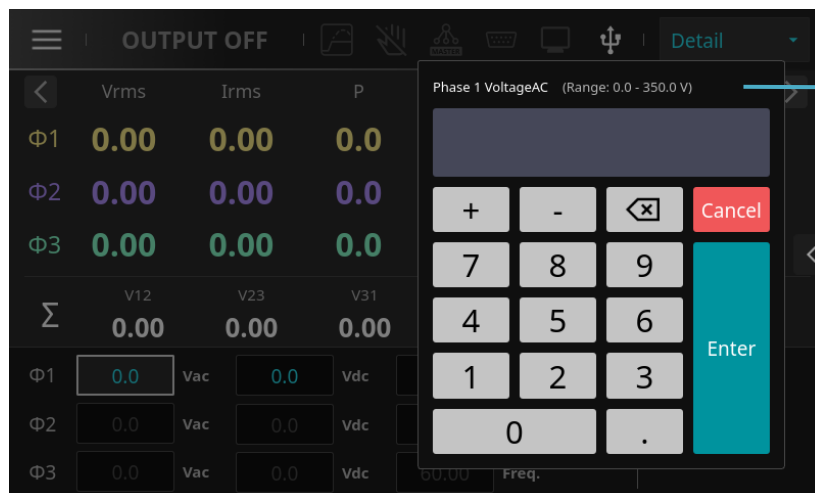

parameter is displayed at the top of the screen. Use the delete button  on the keypad to adjust the setting values during input.



Parameter
Setting Range

Figure 4-6 Numeric Keypad Screen

NOTICE

- The RPS-5000 series provides a DC negative voltage output function. When users need to set a negative voltage, first enter the desired value on the numeric keypad, then press the  button followed by the  button to complete the negative voltage setting

4.3.3 Rotary Knob Operation Instructions

The RPS-5000 series features a pressable rotary knob  , allowing users to dynamically fine-tune parameter values during output. Its functions are as follows:

Selecting Parameter Settings (Vac, Vdc, Freq)

- The rotary knob can be used to select parameter settings. On the device standby main screen, turning the knob clockwise will move to the next parameter setting item, and the selected item will be highlighted with a white frame (as shown in Figure 4-7). Turning the knob counterclockwise will select the previous parameter setting item.

Confirming the Selected Value or Parameter

- After selecting a parameter item, pressing the rotary knob will enter the adjustment mode for that parameter. This is equivalent to pressing the “Enter” key (see Figure 4-8).

Adjusting Values

- In the adjustment mode, turning the rotary knob clockwise will increase the value by 0.1, and turning it counterclockwise will decrease the value. After setting the desired value, press the rotary knob again to confirm and complete the operation.

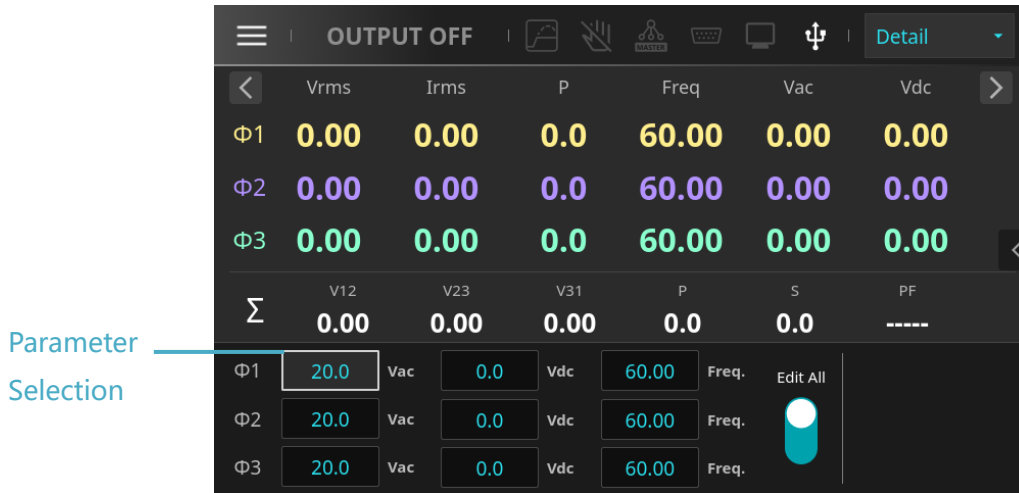

Figure 4-7: Use the knob to select a parameter item

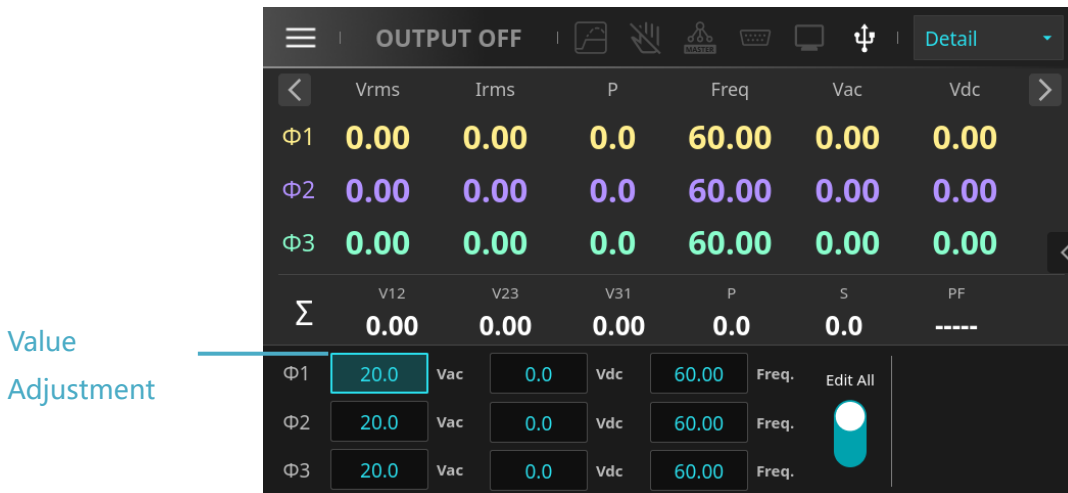



Figure 4-8: Press the knob to adjust the value

4.3.4 Measurement Parameter Selection

The RPS-5000 series provides users with the ability to configure measurement parameters. On the main

screen (Simple page), pressing the  button will open the measurement parameter selection page (as shown in Figure 4-10). This page contains a total of 15 measurement parameter options, including basic voltage, current, active power, and more. Depending on the phase mode, users can set three commonly used measurement parameters on the Simple page, which will then be displayed on the main screen.

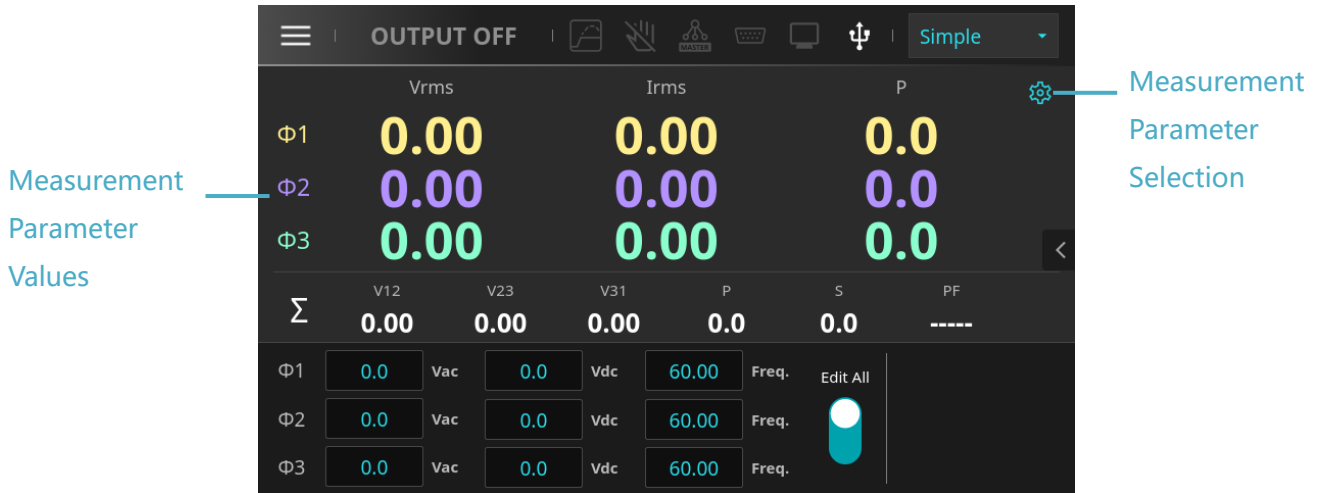

Figure 4-9: Three-phase standby main screen (Simple mode page)

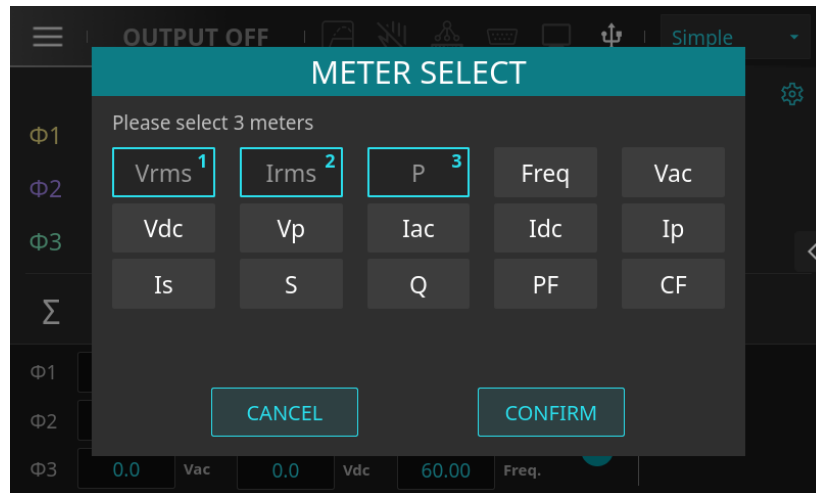



Figure 4-10: Measurement parameter selection page

Measurement Parameter Definitions :

Parameter	Description
Vrms	Voltage measurement value in volts (root mean square).
Irms	Current measurement value in amperes (root mean square).
P	Active power, measured in watts.
F	Frequency, measured in hertz.
Vac	AC voltage, measured in volts (RMS). Calculated as: $V_{ac} = \sqrt{V_{rms}^2 - V_{dc}^2}$

Vdc	DC voltage, measured in volts (average value).
Vp	Peak voltage, measured in volts. Displays the larger of Vp(+) and Vp(-).
Iac	AC current, measured in amperes (RMS). Calculated as: $I_{ac} = \sqrt{I_{rms}^2 - I_{dc}^2}$
Idc	DC current, measured in amperes (average value).
Ip	Peak current, measured in amperes. Displays the larger of Ip(+) and Ip(-).
Is	Inrush peak current, measured in amperes. Represents the peak current during the transient period after output starts.
S	Apparent power, measured in volt-amperes (VA). Calculated as: $V_{rms} \times I_{rms}$.
Q	Reactive power, measured in var (volt-ampere reactive). Calculated as: $\sqrt{(V_{rms}I_{rms})^2 - P_o^2}$.
PF	Power factor, calculated as: $P/V_{rms} \times I_{rms}$
CF	Crest factor, calculated as: I_{peak}/I_{rms}

Using the main screen in three-phase mode (Simple mode page) as an example, the following steps describe how to change the initial measurement parameters from Vrms, Irms, and P to Vrms, Vac, and Vdc:

1. On the main screen in three-phase mode (Simple mode page), press the  button to enter the Measurement Parameter Selection page.
2. Select the parameters you want to replace, such as “Irms” and “P”, as shown in Figure 4-11.
3. Press the desired new parameters “Vac” and “Vdc”, as shown in Figure 4-12.
4. Press the “CONFIRM” button to return to the main screen. The measurement parameters will be updated accordingly, as shown in Figure 4-13.

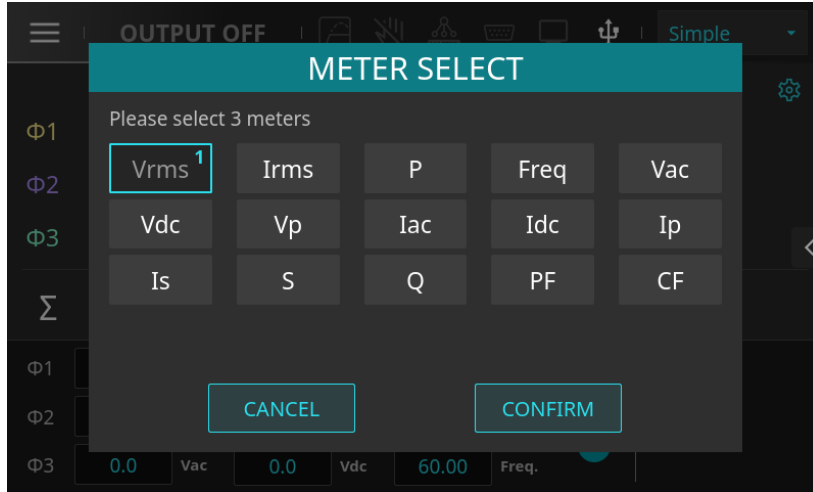

Figure 4-11: Page for deselecting measurement parameters “Irms” and “P”

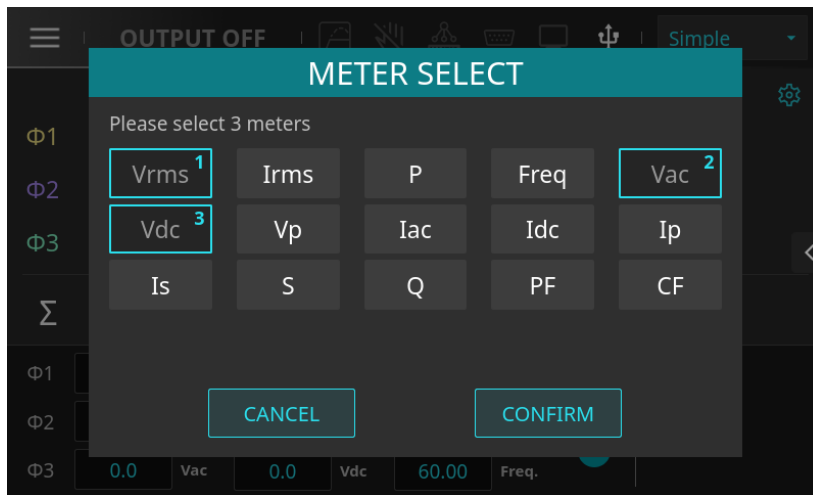

Figure 4-12: Page for selecting measurement parameters “Vac” and “Vdc”

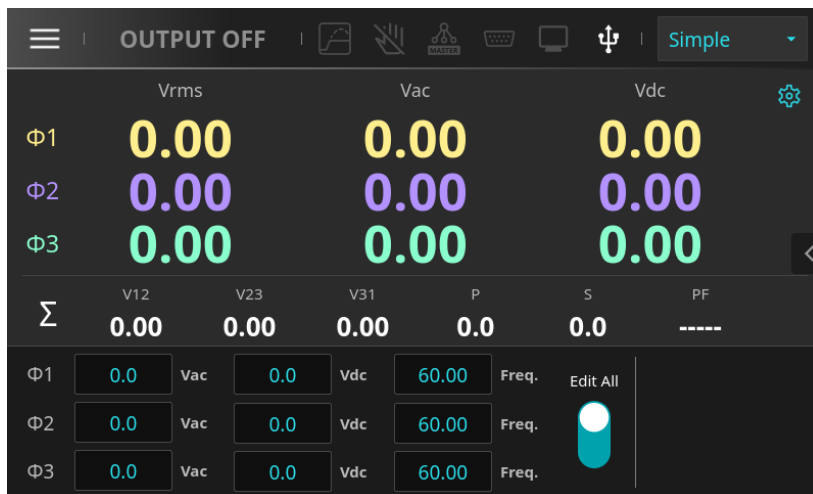



Figure 4-13: Updated measurement parameters on the main screen in three-phase mode (Simple mode page)

4.3.5 Setting Parameter View Box

On the main screen, clicking the icon  on the right side will display the setting parameter view box. This box shows the parameter settings under the current mode (such as start angle, slew rate settings, etc.), allowing users to conveniently check the device's configuration while it is operating.

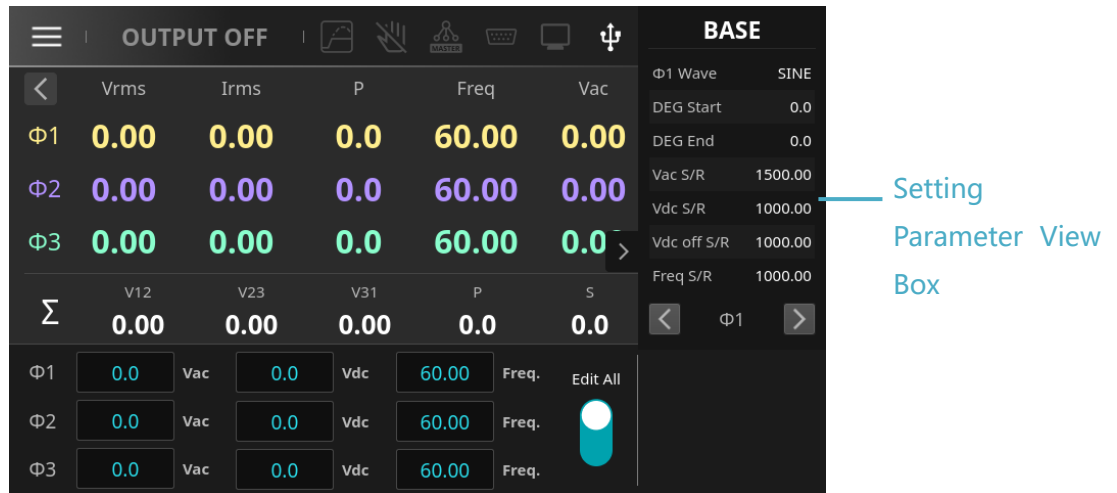
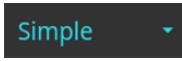

Figure 4-14: Parameter view box information in three-phase Base mode

4.3.6 Measurement Display and Function Menu

This regenerative power system features multiple measurement display modes and functions (**Simple / Detail / Harmonic / Wave**), designed to meet users' operational needs in various scenarios while ensuring data accuracy and readability. As shown in Figure 4-2, users can tap the icon  in the upper right corner of the main screen to open the dropdown menu and select the desired function. The following section provides a detailed explanation of the measurement displays and function menu.

NOTICE

- In the measurement display and function menu on the main screen, users can switch between different mode pages at any time, even while the device is actively outputting. This design ensures uninterrupted operation and allows users to monitor the system status in real time, enhancing both efficiency and flexibility.

- **Simple Mode (Simplified Mode Page)**

In this mode, the screen prominently displays three key measurement parameters with large, clear digits, making it easy to quickly view and verify voltage, current, power, and other values. It is ideal for scenarios requiring rapid inspection of key data and offers an intuitive, user-friendly interface.

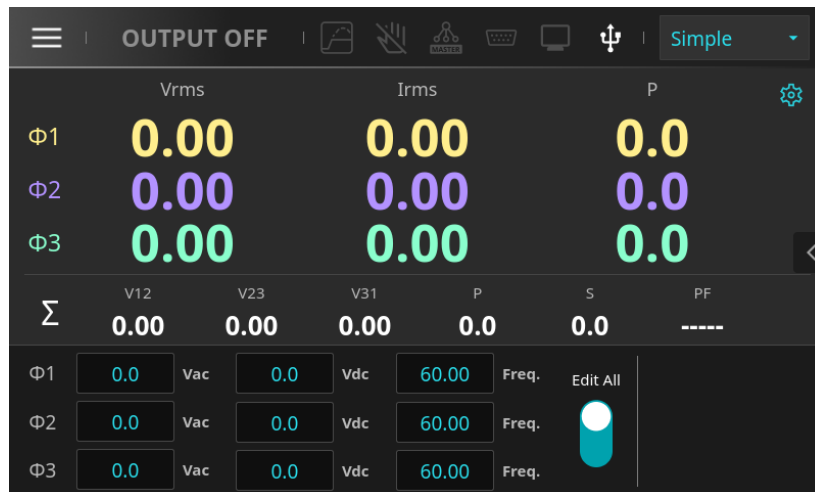



Figure 4-15: Three-phase standby main screen (Simple mode page)

- **Detail Mode (Detailed Mode Page)**

In this mode, the screen displays all 15 measurement parameters. Users can tap the icons on the main screen  and , or directly swipe left or right on the measurement parameter area to view different sets of data. This mode is especially suitable for more complex testing and analysis. It enables users to monitor multiple key parameters simultaneously in multi-variable test environments, thereby improving testing efficiency.

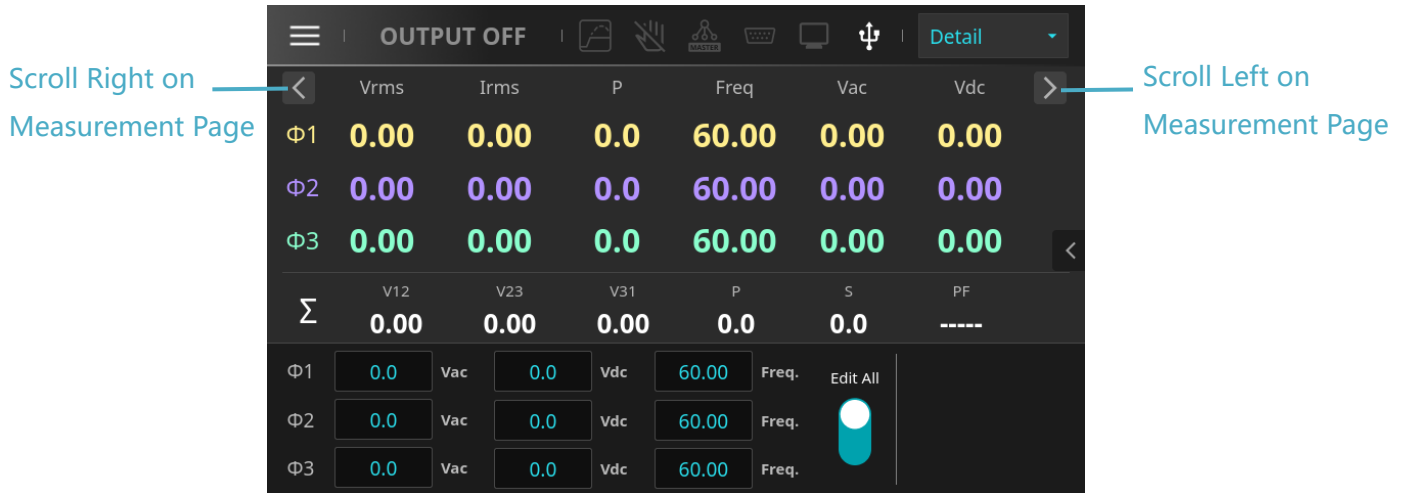

Figure 4-16: Three-phase standby main screen (Detail mode page)

■ Harmonic (Harmonic Measurement Function)

The Harmonic measurement function can perform real-time measurement of the Total Harmonic Distortion (THD) of output voltage and current at the fundamental frequency (F), as well as harmonic data from the 1st to the 50th order. It also provides measurement values for output voltage, current, power, power factor, and crest factor, offering users precise power quality analysis. This function is useful for detecting and analyzing the harmonic distortion of the Device Under Test (DUT), helping to ensure the stability and reliability of the test system.

Figure 4-17 below shows the list interface of the Harmonic measurement page, which simultaneously displays harmonic data from the 1st to the 50th order for both voltage and current at the fundamental frequency (F). It includes voltage/current values, percentages, and phase for each harmonic order. Users can click the



icon on the page to view detailed data for each harmonic order.

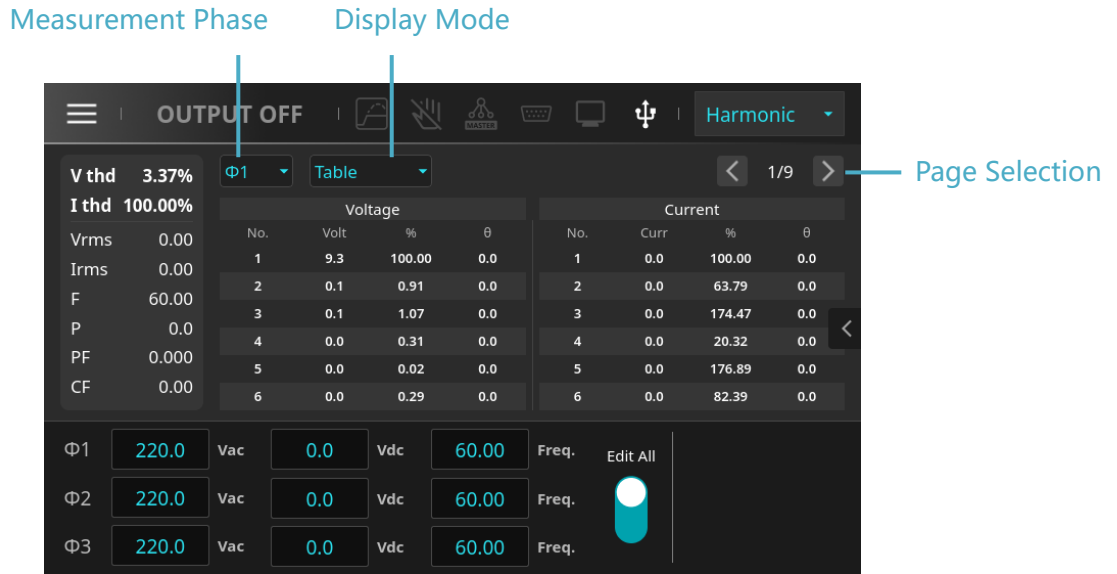

Figure 4-17: Three-phase mode main screen – Harmonic Measurement Page (List View)

Figure 4-18 below shows the Histogram View of the Harmonic Measurement Page. This provides an intuitive and effective way to visualize the amplitude distribution of various harmonic orders. Users can click

27/50 on the page to view detailed data for each harmonic order.

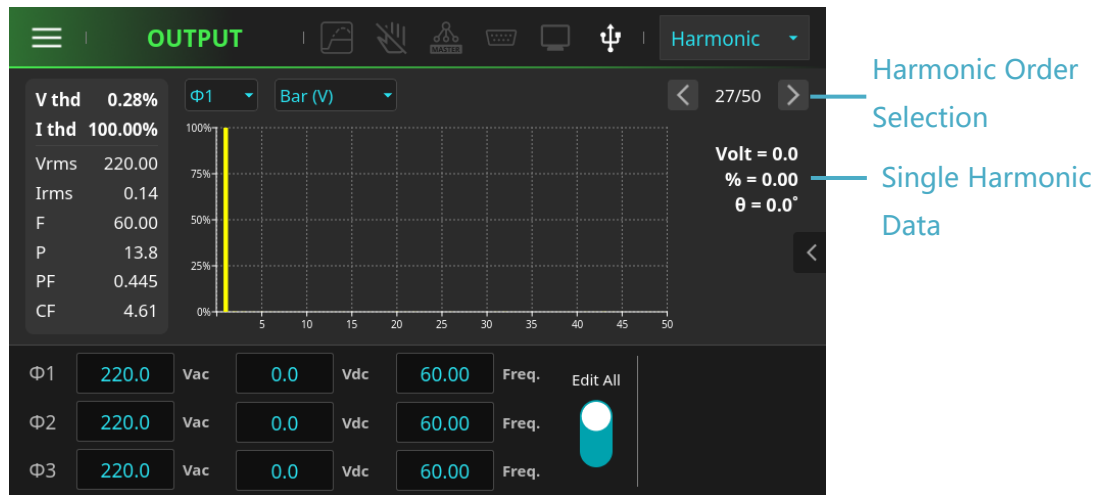

Figure 4-18: Three-phase mode main screen – Harmonic Measurement Page (Histogram View)

Harmonic Measurement Interface (Harmonic) Parameter Descriptions:

Parameter	Sub-item	Description
V thd		Total Harmonic Distortion of output voltage, expressed in %.
I thd		Total Harmonic Distortion of output current, expressed in %.
Vrms		Voltage measurement in volts (root mean square).
Irms		Current measurement in amperes (root mean square).

F		Frequency, measured in hertz.
P		Active power, measured in watts.
PF		Power factor, calculated as $P/V_{rms} \times I_{rms}$
CF		Crest factor, calculated as I_{peak}/I_{rms}
Value		Voltage/Current harmonic amplitude: The magnitude of a specific harmonic.
%		Percentage: Indicates the amplitude ratio of a specific harmonic order to the fundamental.
θ		Phase: The phase angle difference between each harmonic order and the fundamental (or reference waveform), expressed in degrees ($^{\circ}$).
Measurement Phase	<input checked="" type="checkbox"/> $\Phi 1$ <input checked="" type="checkbox"/> $\Phi 2$ <input checked="" type="checkbox"/> $\Phi 3$	$\Phi 1$: Phase 1 $\Phi 2$: Phase 2 $\Phi 3$: Phase 3
Display Mode	<input checked="" type="checkbox"/> Table <input checked="" type="checkbox"/> Bar(V) <input checked="" type="checkbox"/> Bar(I)	Table : List mode (shows voltage/current) Bar(V) : Histogram (shows voltage) Bar(I) : Histogram (shows current)

■ Wave (Waveform Viewing Function)

This function provides real-time waveform display, similar to an oscilloscope, allowing graphical visualization of output voltage and current waveforms. Users can choose to show or hide voltage ($\Phi 1/\Phi 2/\Phi 3$ Volt) and current ($\Phi 1/\Phi 2/\Phi 3$ Curr) waveforms at the output terminals, displaying only the desired waveforms for easier observation. The waveform display interface includes a vertical axis (V/I scale) and a horizontal axis (Time scale) to present the trends and variations in the data.

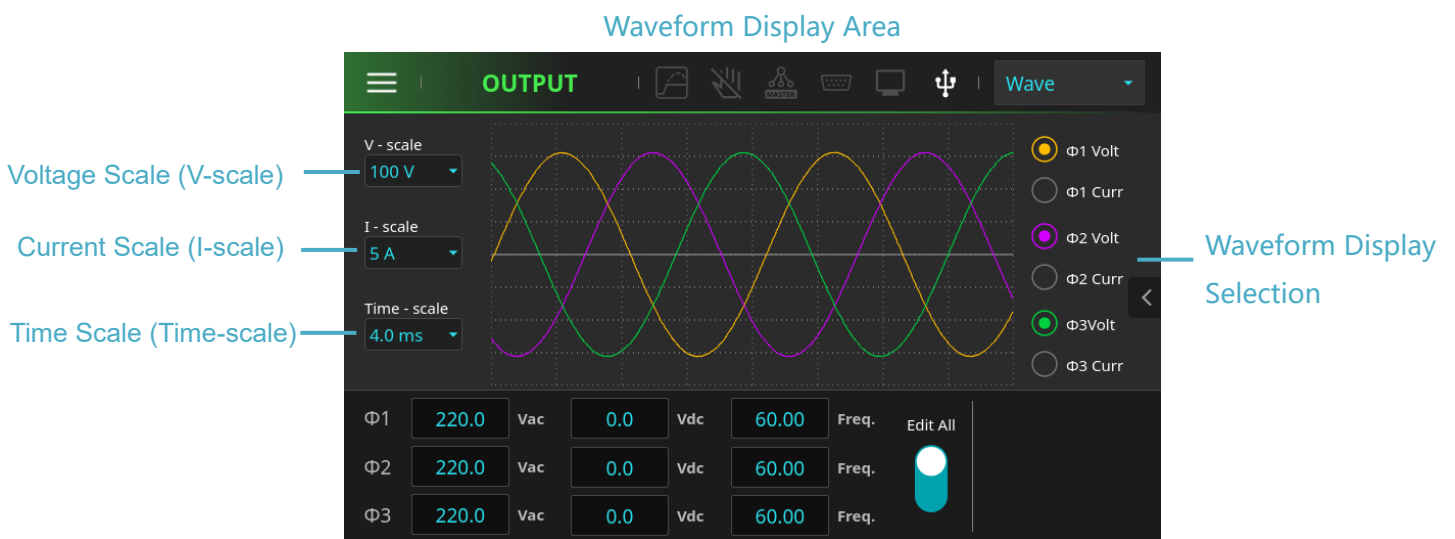



Figure 4-19: Three-phase mode main screen – Wave Page

Waveform Viewing (Wave) Parameter Descriptions:

Parameter	Sub-item	Description
V - scale	10, 20, 50, 100, 200 V/div	Vertical axis voltage scale setting
I - scale	5, 10, 20, 50, 100, 200, 500 A/div	Vertical axis current scale setting
Time - scale	0.8, 1.6, 4, 8, 12 ms/div	Horizontal axis time scale setting

4.4 Main Menu Function Description

Users can press the main menu  button in the upper left corner of the main screen to enter the menu function interface. This interface contains all function option icons, and users can directly touch the desired icon to access the corresponding function setting page. The function options include Mode Setting, Output Config, System, Wave Select, Protection, Save/Load, and Information, totaling seven function options.

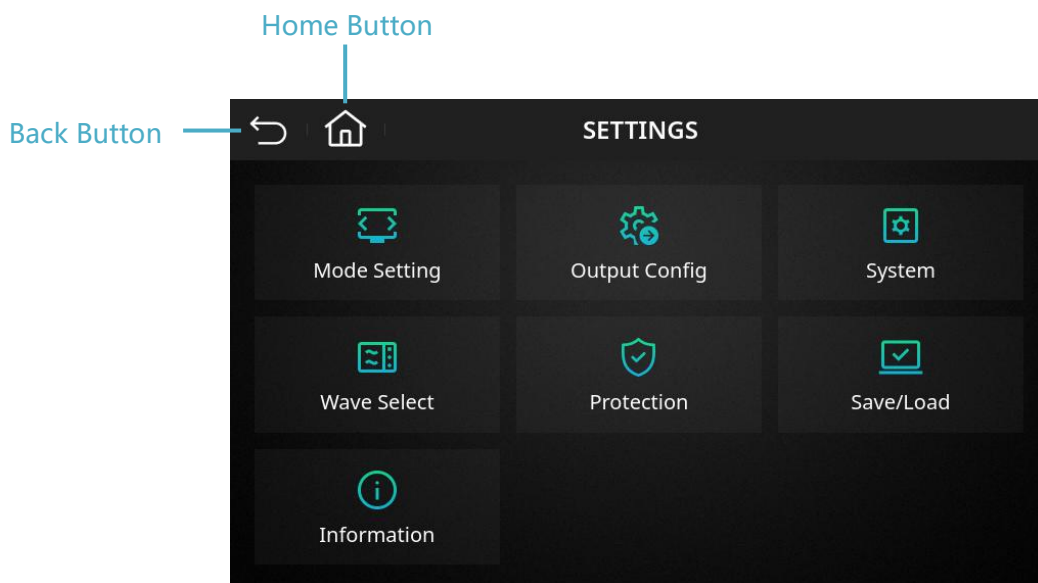



Figure 4-20: Main Menu Function Page

NOTICE

- When the device is in the output state (OUTPUT ON), pressing the main menu  button will not allow access to the function setting pages. Users must first turn off the output (OUTPUT OFF) before they can enter the main menu and perform related operations.

4.5 Output Configuration Setting (Output Config)

On the main menu function page, press the  function key to enter the Output Configuration Setting page (Output Config). The function options include Phase, Output, Slew Rate, Isurge (Inrush Current Measurement), and Impedance (Programmable Output Impedance Setting), as shown in Figure 4-21.

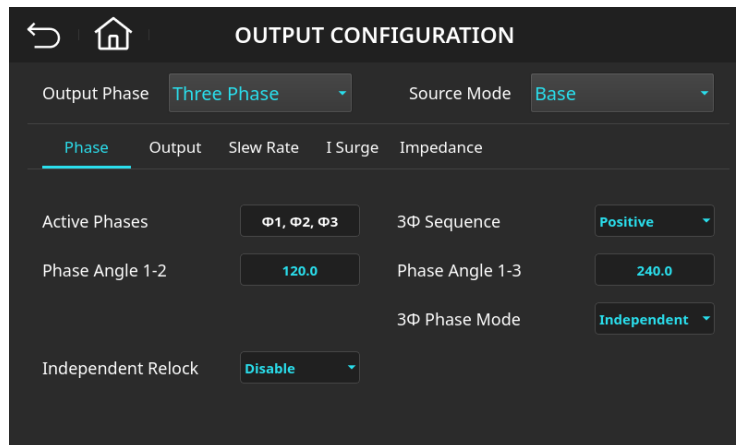

Figure 4-21: Output Configuration Setting Page

Output Configuration – Parameter Description:

Parameter	Sub-item	Description
Output Phase	<ul style="list-style-type: none"> ■ Three Phase ■ Single Phase ■ Split Phase 	Output phase mode selection
Source Mode	<ul style="list-style-type: none"> ■ Base ■ List ■ Step ■ Pulse ■ Synthesis ■ Interharmonic ■ Transient 	Advanced mode selection
Phase	See Section 4.5.3 for details	Settings under output phase mode, including phase sequence, phase angle difference, parameters for three-phase/split-phase modes, and re-lock phase angle function.
Output	See Section 4.5.4 for details	Output settings including output coupling mode, start/end angle, output relay settings, number of averages for measurement values, and output response parameters.
Slew Rate	See Section 4.5.5 for details	Slew rate settings (including Vac, Vdc, F)
Isurge	See Section 4.5.6 for details	Inrush current measurement function
Impedance	See Section 4.5.7 for details	Programmable output impedance function

4.5.1 Output Phase Switching (Output Phase)

This regenerative power system supports three-phase, single-phase, and split-phase operation modes.

Users can switch modes through the operation interface according to their testing requirements. Refer to Figure

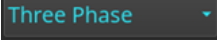
4-21 and tap the icon  in the upper left corner of the main screen to open the dropdown menu and select the desired phase mode.

■ Three Phase

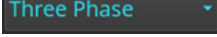
When a three-phase AC power source is required, refer to Figure 4-21 and tap the icon  in the upper left corner of the main screen to open the dropdown menu, then follow the steps below to switch to three-phase mode:

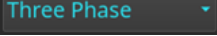
1. On the Output Configuration page (OUTPUT CONFIGURATION), tap .
2. Select "Three Phase".
3. After confirming the output wiring is in three-phase mode, press the "CONFIRM" button, as shown in Figure 4-22.
4. The system will automatically return to the main screen and switch to three-phase mode.

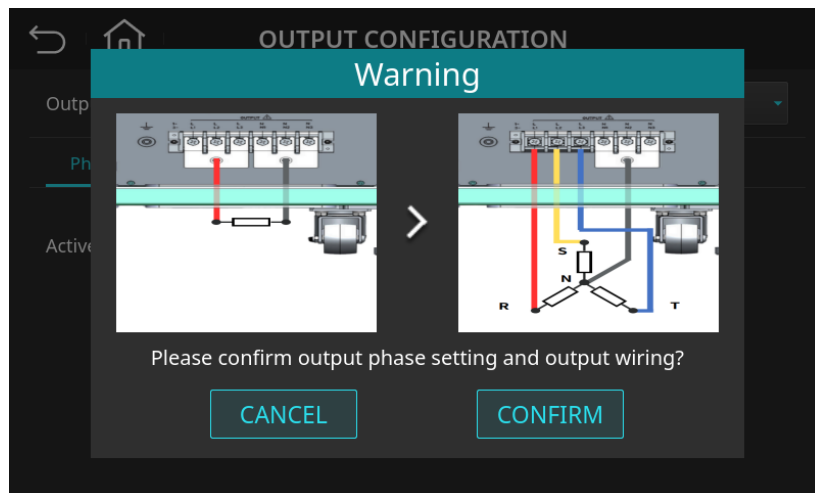



Figure 4-22: Phase Mode Switching Warning Page (Switching from Single Phase to Three Phase)

NOTICE

- After the system is powered on and enters the standby main screen, if the user selects a phase mode that matches the current phase mode, the system will not display the phase mode switching warning page.

- **Single Phase**

When a single-phase AC power source is required, refer to Figure 4-21 and tap the icon  in the upper left corner of the main screen to open the dropdown menu, then follow the steps below to switch to single-phase mode:

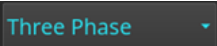
1. On the Output Configuration page (OUTPUT CONFIGURATION), tap .
2. Select "Single Phase".
3. After confirming the output wiring is in single-phase mode, press the "CONFIRM" button, as shown in Figure 4-23.
4. The system will automatically return to the main screen and switch to single-phase mode.

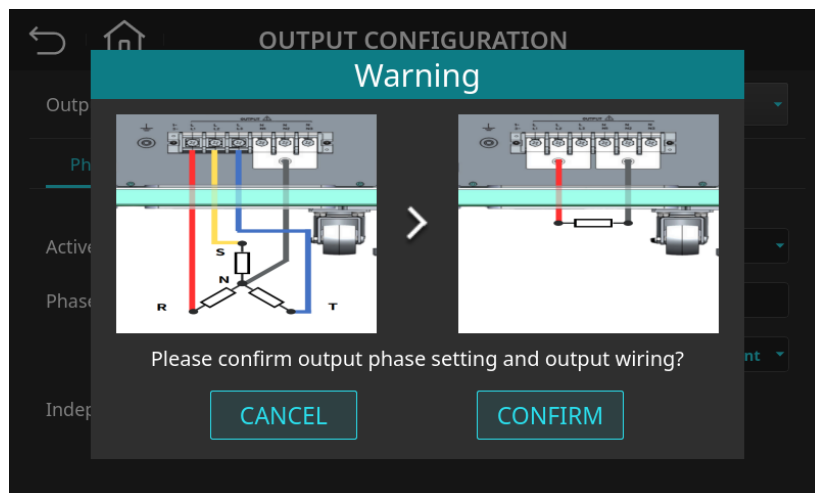

Figure 4-23: Phase Mode Switching Warning Page (Switching from Three Phase to Single Phase)

NOTICE

- When switching from Single Phase to Three Phase or Split Phase mode, users must ensure that the shorting copper bars between output terminals L1, L2, and L3 have been removed to prevent triggering the protection mechanism of the regenerative power system.

- **Split Phase**

When high-voltage single-phase output or dual-line testing is required, the voltage can be increased to twice the original phase voltage, and the power will be two-thirds of the full rated power. Refer to Figure 4-21 and tap the **Three Phase** icon in the upper left corner of the main screen to open the dropdown menu, then follow the steps below to switch to split-phase mode:

1. On the Output Configuration page (OUTPUT CONFIGURATION), press the **Three Phase** button.
2. Select “Split Phase”.
3. After confirming the output wiring is in split-phase mode, press the “CONFIRM” button, as shown in Figure 4-24.
4. The system will automatically return to the main screen and switch to split-phase mode.

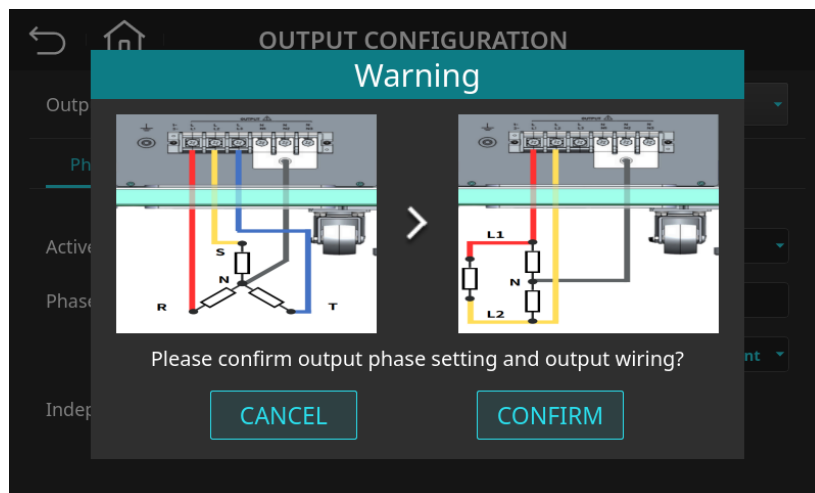



Figure 4-24: Phase Mode Switching Warning Page (Switching from Three Phase to Split Phase)

NOTICE

- During split-phase operation, the output of the regenerative power system is limited to the L1 and L2 terminals with specified voltage output. Terminals L3 to N remain at 0V with no output voltage to prevent incorrect operation or testing errors. Please ensure that the terminal wiring configuration complies with this setup to avoid abnormal loads.
- In split-phase operation, advanced setting functions are only available in Base mode (Source Mode set to Base).
- When switching between single-phase, three-phase, or split-phase modes, the previously set basic parameter values will be automatically reset to zero to prevent damage to the DUT and ensure safety during the testing process.

4.5.2 Advanced Mode Setting (Source Mode)

The Source Mode function menu (see Figure 4-21) allows users to quickly switch advanced mode functions under the Output Configuration page. Tap the  icon in the upper right corner of the page to open the dropdown menu. The advanced modes include Base, List, Step, Pulse, Synthesis, Interharmonic, and Transient—seven options in total, which can be configured based on testing needs. For detailed setup procedures and descriptions of each mode, please refer to Chapter 5 (Advanced Mode Settings).

4.5.3 Phase Output Setting

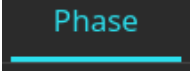
Users can refer to Figure 4-21 and tap the  icon on the screen to enter the Phase Output Setting page, then proceed to select the required parameters.

- **Phase Sequence and Phase Angle Difference Setting**

In the three-phase mode of the regenerative power system, users can choose either positive phase sequence (RST) or negative phase sequence (RTS) for phase arrangement.

Positive phase sequence (RST) indicates the output phases follow L1, L2, L3, with phase angles increasing by 120 degrees.

Negative phase sequence (RTS) indicates the output phases follow L1, L3, L2, with phase angles decreasing by 120 degrees, as shown in Figures 4-25 and 4-26.

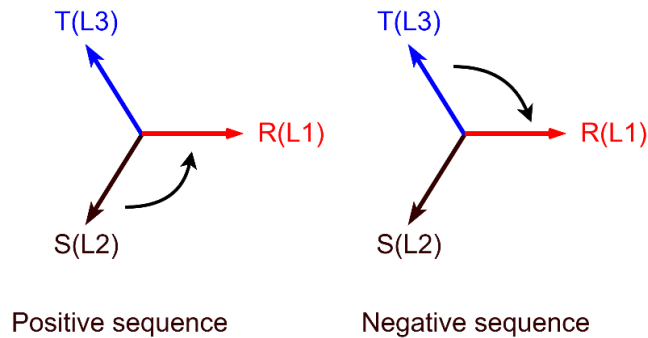

Figure 4-25: Illustration of Positive and Negative Phase Sequences in Three-Phase Mode

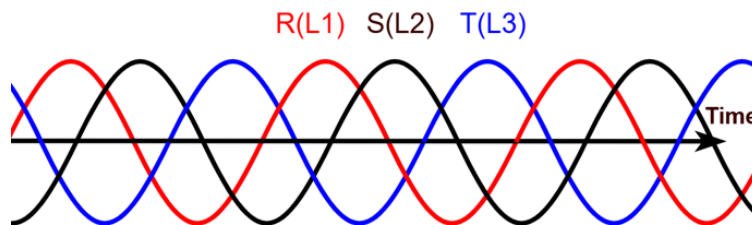

Figure 4-26: Waveform Diagram of Positive Phase Sequence in Three-Phase Mode

When a negative phase sequence output is required for a three-phase power source, refer to Figure 4-21

and tap the 3 Φ Sequence icon **Positive** on the screen to open the dropdown menu. Then follow the steps below to switch to the negative phase sequence.

1. On the Output Configuration page (OUTPUT CONFIGURATION), tap **Phase**.
2. Tap the 3 Φ Sequence icon **Positive** on the screen to open the dropdown menu.
3. Select "Negative", as shown in Figure 4-27.

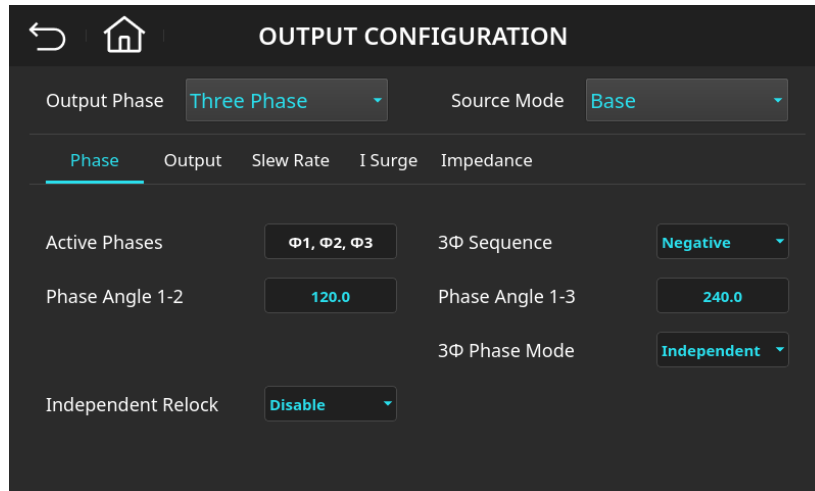
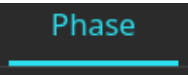

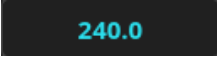



Figure 4-27: Output Configuration (Phase) Page – Negative Phase Sequence Setting

In three-phase mode, when set to Independent, the regenerative power system allows the output voltage and frequency of each phase to be adjusted independently. When the three-phase output is configured as unbalanced, users can customize the phase angle differences as needed—for example, Phase Angle 1-2 = 90° and Phase Angle 1-3 = 270°. This is particularly important for applications that require simulation of various unbalanced load conditions, such as in power system stability analysis and equipment performance evaluation.

The procedure for setting the output voltage to a three-phase unbalanced configuration is as follows:

1. On the Output Configuration page (OUTPUT CONFIGURATION), tap .
2. Tap the numeric input field for Phase Angle 1-2, marked as  on the screen.
3. Enter 9, 0 then press the  key. The value will change to “90.0”.
4. Tap the numeric input field for Phase Angle 1-3, marked as  on the screen.
5. Enter 2, 7, 0, then press the  key. The value will change to “270.0”, as shown in Figure 4-28.

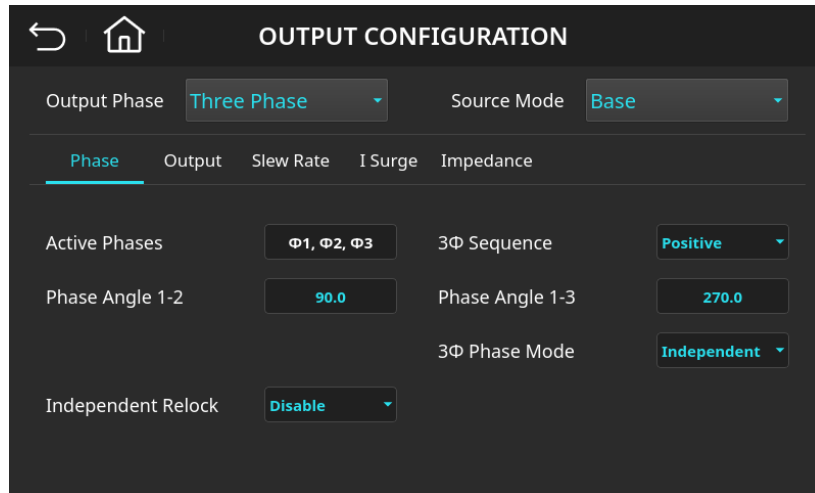

Figure 4-28: Output Configuration (Phase) Page – Phase Angle 1-2 = 90.0, Phase Angle 1-3 = 270.0

■ 3Φ Phase Mode Setting

In the 3Φ Phase Mode setting, users can select the relative relationship between the three-phase output voltages of the regenerative power system, allowing the output configuration to be adjusted according to specific testing requirements. The three-phase output voltage relationship includes the following three mode options:

1. Independent Mode – Allows each phase's voltage and frequency to operate independently, suitable for simulating asymmetric load testing.
2. Same Frequency Mode (Same Freq) – In this mode, all three phases share the same frequency, while the voltages can be adjusted separately, ideal for simulating testing environments with varying parameters.
3. Balanced Mode – Voltage and frequency are equal across all three phases, with a fixed 120-degree phase angle, used in standard testing scenarios that require stable and symmetrical loads.

The procedure for setting the Same Frequency Mode (Same Freq) is as follows:

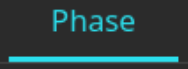
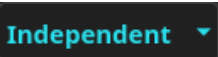
1. On the Output Configuration page (OUTPUT CONFIGURATION), tap .
2. Tap the 3Φ Phase Mode icon  on the screen to open the dropdown menu.
3. Select "Same Freq".

- Tap the Home button  to return to the main screen. As shown in Figure 4-29, the frequency of all three phases will now be the same.

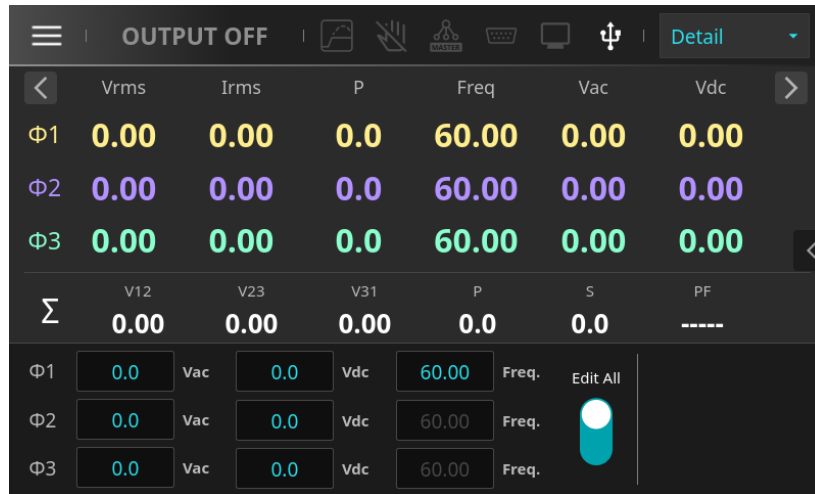
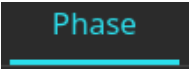
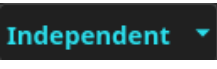



Figure 4-29: Three-Phase Mode Main Screen (Same Freq)

In three-phase Balanced mode, users can choose to set the output voltage as either Phase Voltage or Line Voltage, allowing flexibility in selecting the voltage reference type according to specific testing requirements.

The procedure for setting Balanced mode with the voltage configured as Phase is as follows:.

- On the Output Configuration page (OUTPUT CONFIGURATION), tap .
- Tap the 3Φ Phase Mode icon  on the screen to open the dropdown menu.
- Select "Balanced".
- Tap the Balanced V Format icon  on the screen to open the dropdown menu.
- Select "Phase", as shown in Figure 4-30.
- Tap the Home button  to return to the main screen. As shown in Figure 4-31, the voltage and frequency across the three phases are equal, and the voltage is set to Phase.

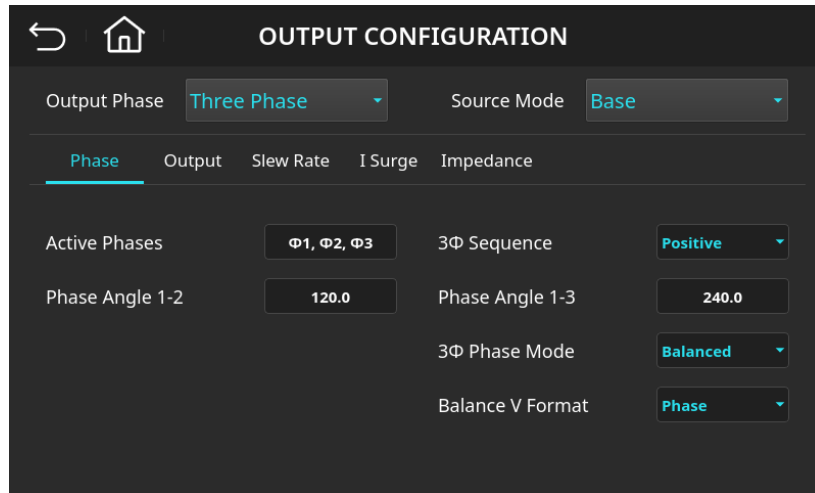

Figure 4-30: Output Configuration (Phase) Page – Balanced Mode with Phase Voltage Setting

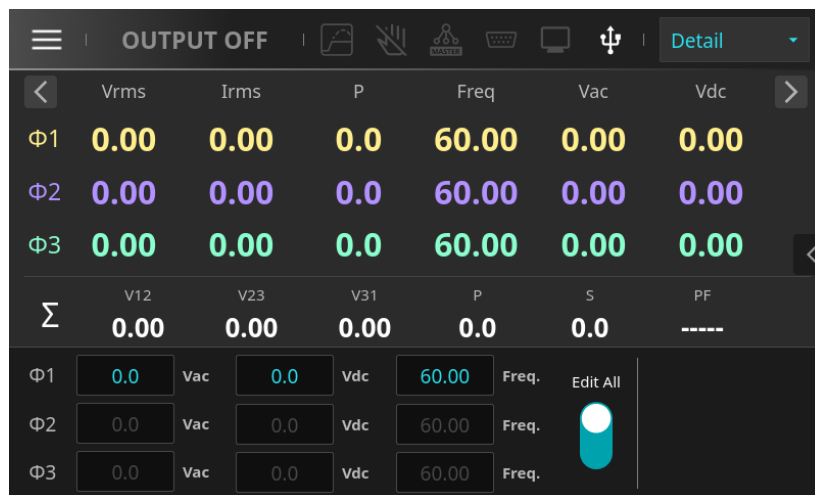

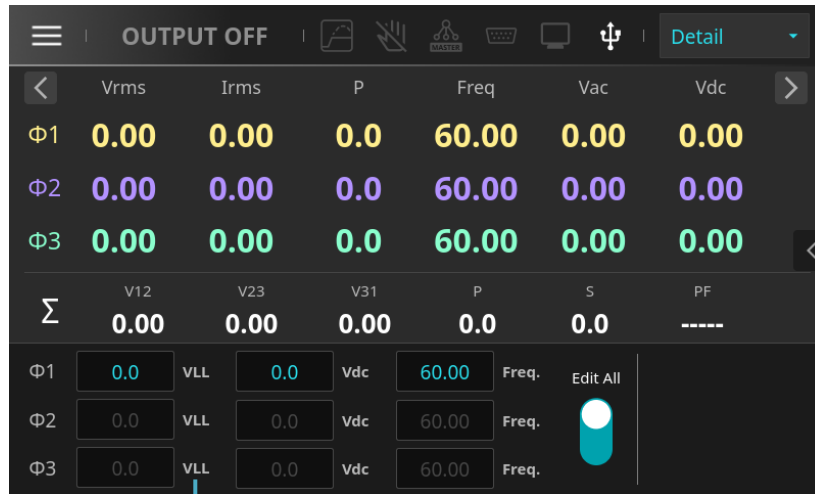

Figure 4-31: Three-Phase Mode Main Screen – Balanced Mode with Phase Voltage Setting (Phase)

The procedure for setting Balanced mode with the voltage configured as Line Voltage (Line) is as follows:

1. On the Output Configuration page (OUTPUT CONFIGURATION), tap **Phase**.
2. Tap the 3Φ Phase Mode icon **Independent** on the screen to open the dropdown menu.
3. Select “Balanced”.
4. Tap the Balanced V Format icon **Phase** on the screen to open the dropdown menu.
5. Select “Line”.
6. Tap the Home button  to return to the main screen. As shown in Figure 4-32, the voltage and frequency across the three phases are equal, and the voltage is set to Line.



Line Voltage Setting

Figure 4-32: Three-Phase Mode Main Screen – Balanced Mode with Line Voltage Setting (Line)

NOTICE

- When set to Three-Phase Mode, and the 3Φ Phase Mode is configured as Balanced, users can choose between Phase (phase voltage) or Line (line voltage). However, this setting is only applicable when the waveform is set to Sine Wave. When Phase is selected, the displayed voltage is the phase voltage (Vac)—the voltage relative to the neutral point. When Line is selected, the displayed voltage is the line voltage (VLL)—the voltage between phases, where $VLL = Vac \times 1.732$ ($\sqrt{3}$ multiplier).
- **Independent Relock Setting**

Independent Relock is a phase re-locking function. When the 3Φ Phase Mode is set to Independent in three-phase mode, the regenerative power system allows independent voltage and frequency settings for each phase, enabling each phase to output a different frequency. Users can refer to Figure 4-19 and tap the Independent Relock indicator button **Disable** to enable or disable this function, depending on their specific testing requirements.

1. **Independent Relock = Disable**: If the output frequencies of the three phases are different, and the user sets all three frequencies to be the same during output, the phase difference between the outputs will not automatically return to the default 120°, as shown in Figure 4-33.
2. **Independent Relock = Enable**: If the output frequencies of the three phases are different, and the user sets all three frequencies to be the same during output, the phase difference between the outputs will automatically return to the default 120°, as shown in Figure 4-34.

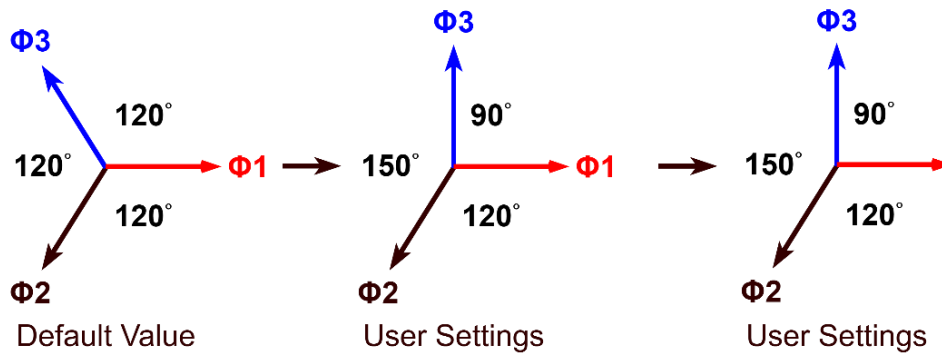

Figure 4-33: Output Configuration (Phase) Page – When Independent Relock is Disabled

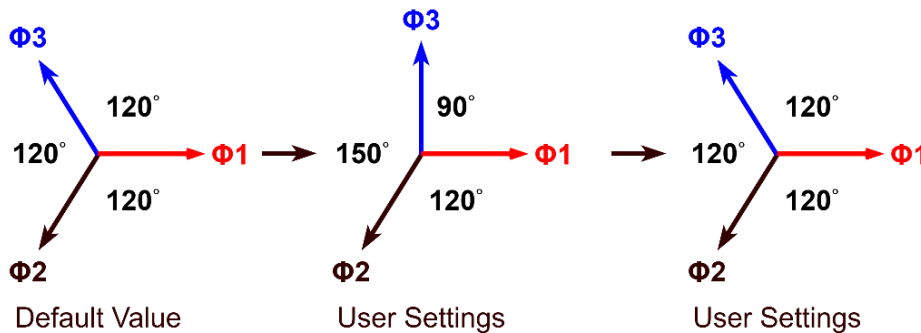

Figure 4-34: Output Configuration (Phase) Page – When Independent Relock is Enabled

Output Configuration (Phase) Parameter Descriptions:

Parameter	Sub-item	Description
Active Phases	<ul style="list-style-type: none"> ■ Three Phase(Φ1, Φ2, Φ3) ■ Single Phase(Φ1) ■ Split Phase(Φ1, Φ2) 	Displays the currently active output phases.
3Φ Sequence	<ul style="list-style-type: none"> ■ Positive ■ Negative 	Phase sequence setting in three-phase mode.

Phase Angle 1-2	0.0 ~ 359.9 deg	Phase angle difference between L1 and L2.
Phase Angle 1-3	0.0 ~ 359.9 deg	Phase angle difference between L1 and L3.
3 Φ Phase Mode	<ul style="list-style-type: none"> ■ Independent ■ Same Freq ■ Balanced 	Defines the relationship between the output voltages in three-phase mode.
Independent Relock	<ul style="list-style-type: none"> ■ Enable ■ Disable 	Phase re-locking function in three-phase mode.
Balanced V Format	<ul style="list-style-type: none"> ■ Phase ■ Line 	Voltage format selection in balanced three-phase mode.

4.5.4 Output Setting

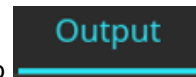
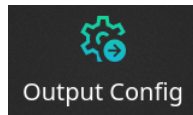

On the main menu function page, tap the **Output Config** function key, then tap **Output** to enter the Output Configuration (Output) setting page, as shown in Figure 4-35.

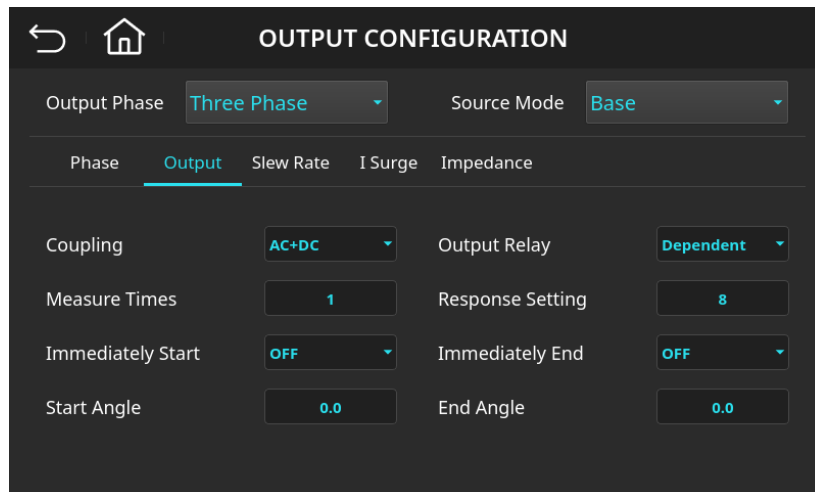

Figure 4-35: Output Configuration (Output) Setting Page

Output Configuration (Output) Parameter Descriptions:



Parameter	Sub-item	Description
Coupling	<ul style="list-style-type: none"> ■ AC ■ DC ■ AC+DC 	Output mode setting
Output Relay	<ul style="list-style-type: none"> ■ Dependent ■ Always On 	Output relay setting
Measure Times	1 ~ 32	Number of averages for measured parameter values
Response Setting	1 ~ 15	Output Response Speed Setting

Immediately Start	<input type="checkbox"/> ON <input type="checkbox"/> OFF	Arbitrary Angle Output Voltage
Start Angle	0.0 ~ 359.9 deg	Output Voltage Start Angle
Immediately End	<input type="checkbox"/> ON <input type="checkbox"/> OFF	Arbitrary Angle Stop Output Voltage
End Angle	0.0 ~ 359.9 deg	Output Voltage End Angle

■ Output Mode Setting (AC, DC, AC+DC)

The RPS-5000 series regenerative power system provides three output modes: AC, DC, and AC+DC. Users can select the appropriate mode from the system menu based on their application requirements to fulfill specific testing needs.

The procedure for changing the output mode setting from AC+DC to AC is as follows:

1. On the Output Configuration page (OUTPUT CONFIGURATION), tap .
2. Tap the Coupling icon  on the screen to open the dropdown menu.
3. Select "AC".
4. Tap the Home button  to return to the main screen. As shown in Figure 4-36, the output mode in three-phase mode has now been changed to AC.

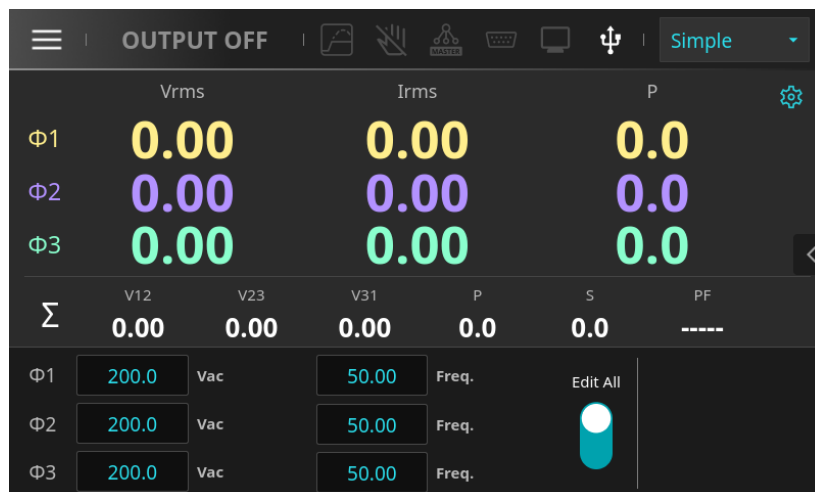

Figure 4-36: Three-Phase Mode Main Screen (Coupling = AC)

NOTICE

- DC Mode not only expands the application range of pure AC voltage but also broadens the scope of DC output in testing scenarios. However, this regenerative power system differs from traditional DC power supplies in design, featuring a smaller output capacitance, which results in different characteristics. Excessive capacitance may lead to system instability and potentially trigger protection mechanisms, affecting normal operation.
- When using DC Mode for testing, it is important to understand the ripple parameters associated with the device operating as a DC power source. If the test requires low noise, it is recommended to add an external filter to ensure low-noise and stable DC voltage output, enabling precise testing.
- If Current Limit Control is not enabled, using DC Mode to perform tests that reach the device's rated current will trigger the protection mechanism, causing the output relay to disconnect. This behavior differs from that of traditional DC power supplies, which typically enter constant current mode under such conditions.
- **Output Relay Configuration**

The regenerative power system includes relays on its output lines to connect the load. This feature allows users to configure relay behavior. When the relay is set to “Always On” and OUTPUT ON is pressed, the relay remains closed (energized), even when the output is turned OFF—it will not disconnect. When the relay is set to “Dependent”, the relay closes only during OUTPUT ON mode and automatically opens (disconnects) when the system is in OUTPUT OFF mode.

The “Relay Always On” function is designed to ensure that the output relay remains closed (connected to the load) under all output states, including standby. This function is especially useful in testing or operational environments where continuous and stable output is required, and where the load must remain connected to the supply. It helps prevent issues such as poor contact or instability caused by frequent relay switching, enhancing connection safety and improving operational reliability and efficiency.

The procedure for setting the output relay configuration to “Always On” is as follows:

1. On the Output Configuration page (OUTPUT CONFIGURATION), tap **Output**.
2. Tap the Output Relay icon **Dependent** on the screen to open the dropdown menu.
3. Select “Always On” to complete the setting, as shown in Figure 4-37.

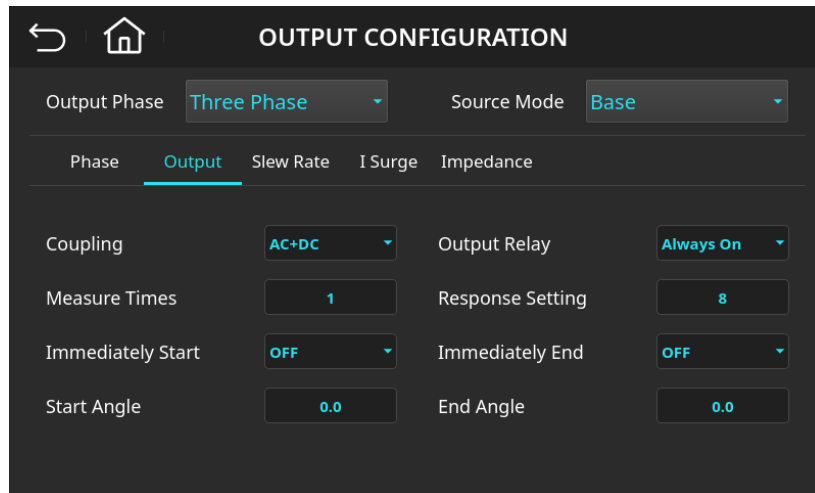

Figure 4-37: Output Configuration (Output) Page – Output Relay Set to “Always On”

NOTICE





- When the relay configuration is set to “Always On”, the relay will remain closed after the first press of OUTPUT ON. In this state, the relay will only automatically open if the system triggers the protection function, ensuring continuous power supply to the load, unless an overload or abnormal condition occurs.

■ Measure Times

In the regenerative power system, the Measure Times function is used to set the number of sampling averages for the voltage/current RMS (Root Mean Square) values. This menu specifies the number of samples to be averaged within the designated measurement range, improving measurement accuracy, especially when the measured values fluctuate significantly.

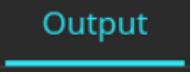
For example, when Measure Times is set to 8, it means 8 samples will be taken and averaged. Users can adjust the sampling average number by tapping the indicator button below Measure Times. Selecting a higher sampling number helps stabilize the displayed data and improve measurement accuracy.

The procedure for setting the Measure Times to “4” is as follows:

1. On the Output Configuration page (OUTPUT CONFIGURATION), tap .
2. Tap the numeric input field for Measure Times  on the screen.
3. Enter  and press the  key. The value will change to “4”, as shown in Figure 4-38.

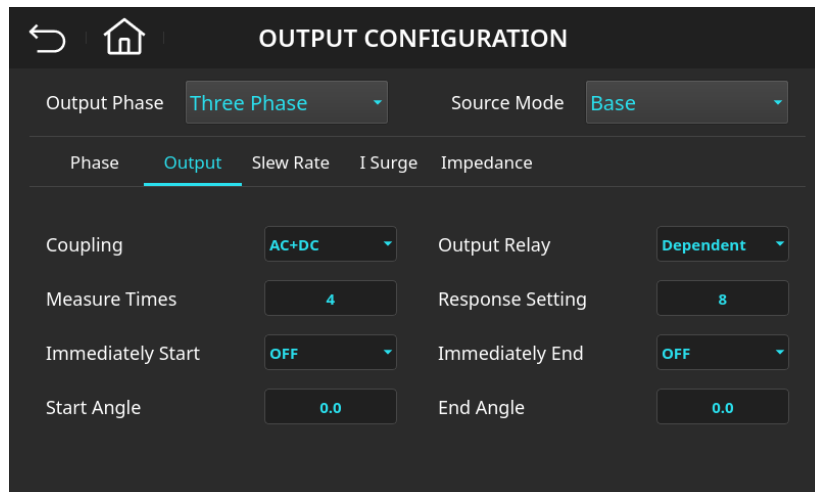

Figure 4-38: Output Configuration (Output) Page – Measure Times Set to 4

■ Response Setting





The regenerative power system provides the Response Setting function to adapt to different load conditions. It adjusts the controller of the internal output stage to match the requirements of the device under test (DUT). This setting allows users to adjust the output response speed to suit various load conditions. The response speed parameter can be set in the range of 1 to 15, with the default value set to 8. The specific usage scenarios are as follows:

- A. High-Speed Response (Recommended range: 11 to 15):** Suitable for applications that require quick rise and fall times of the power source, such as purely resistive loads. In this mode, the dynamic response is faster, but it may cause output instability or oscillations with inductive or capacitive loads. Before conducting tests, ensure the output voltage waveform is stable.
- B. Medium-Speed Response (Recommended range: 6 to 10, default is 8):** This mode provides a balanced response speed, offering a good mix of output stability and dynamic performance. It is particularly suitable

for loads with more stable frequencies, such as equipment operating within the range of the power grid frequency. Medium-speed response offers enough load adaptability and is effective for handling inductive or lightly capacitive loads while avoiding instability caused by load variations.

- C. **Low-Speed Response (Recommended range: 1 to 5):** Ideal for scenarios requiring stable power delivery, especially for large capacitive loads. This setting ensures stable operation when large capacitive loads are connected to the output.

The procedure for setting the response speed to “Response Setting = 6” is as follows:

1. On the Output Configuration page (OUTPUT CONFIGURATION), tap .
2. Tap the numeric input field for Response Setting  on the screen.
3. Enter  and press the  key. The value will change to “6”, as shown in Figure 4-39.
4. Tap the Home button  to return to the main screen. The response speed setting will be completed and applied to the output parameters.

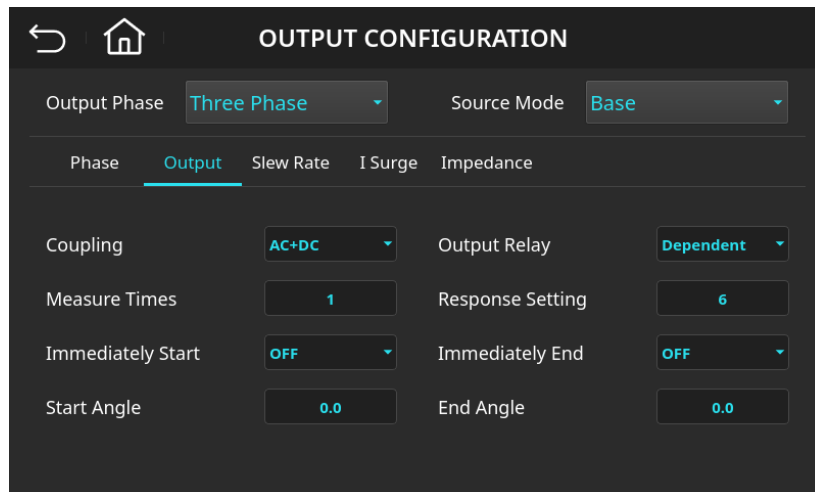

Figure 4-39: Output Configuration (Output) Page – Response Setting Set to 6

NOTICE





- After the user changes the Response Setting value, the three-phase voltage must be recalibrated. Failure to do so may result in the voltage not reaching the expected setting when a lower value is configured, which could trigger the VSENSE_UVP protection mechanism.

WARNING

- Before adjusting the Response Setting parameters, it is recommended to first confirm the load characteristics of the device under test (DUT). After adjusting the response speed parameters, connect the DUT and conduct tests to check for any oscillations, as this could trigger the OVP_PEAK (Over Voltage Protection Peak) mechanism. If instability or oscillations in the output voltage waveform are observed, adjust the parameter values accordingly to ensure the stability of the test process and maintain the safe operation of the equipment.
- **Output Angle (Start / End Angle)**

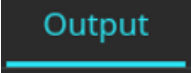
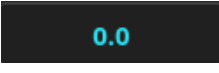
The regenerative power system's Start Angle and End Angle settings allow users to precisely control the starting and ending points of the AC output voltage phase. This setting is useful for simulating phase requirements under different load conditions, ensuring accurate waveform control during device protection and performance testing.

The procedure for setting the output to Start Angle = 90 deg and End Angle = 270 deg is as follows:

1. On the Output Configuration page (OUTPUT CONFIGURATION), tap .
2. Tap the numeric input field for Start Angle  on the screen.
3. Enter , , then press the  key. The value will change to "90.0".
4. Tap the numeric input field for End Angle  on the screen.
5. Enter , , , then press the  key. The value will change to "270.0", as shown in Figure 4-40.

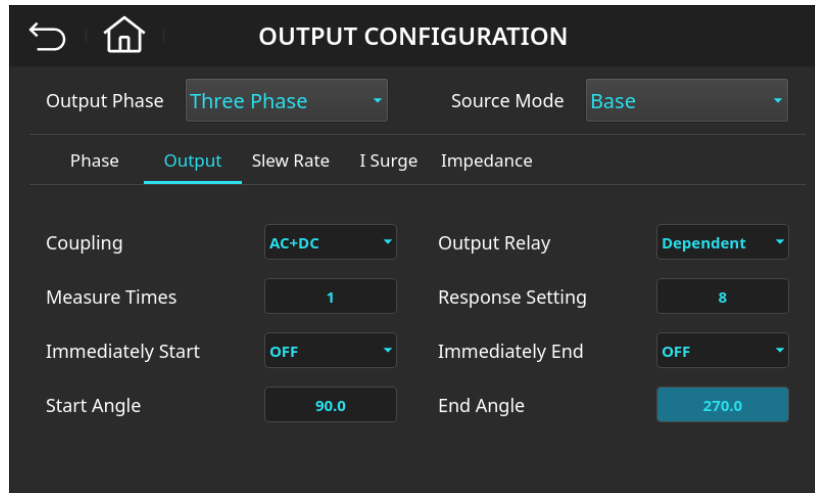



Figure 4-40: Output Configuration (Output) Page – Start Angle Set to 90° and End Angle Set to 270°

NOTICE

- When the Immediately Start function is set to “ON”, pressing OUTPUT ON will immediately start the voltage output at an arbitrary starting angle. When the Immediately End function is set to “ON”, if OUTPUT OFF is pressed while there is voltage output, the voltage will decrease to 0V at the current angle, and the output relay will disconnect.
- In three-phase mode, the Start/End Angle setting primarily controls the phase of the L1 phase. The phases of L2 and L3 are synchronized based on the internal phase difference set by the system when 3Φ Phase Mode = Independent. These phases correspond to the Phase Angle 1-2 and Phase Angle 2-3 settings, respectively.

4.5.5 Output Slew Rate Setting (Slew Rate)

In the main menu function page, tap the  function key, then tap  to enter the Output Slew Rate (Slew Rate) setting page, as shown in Figure 4-41.

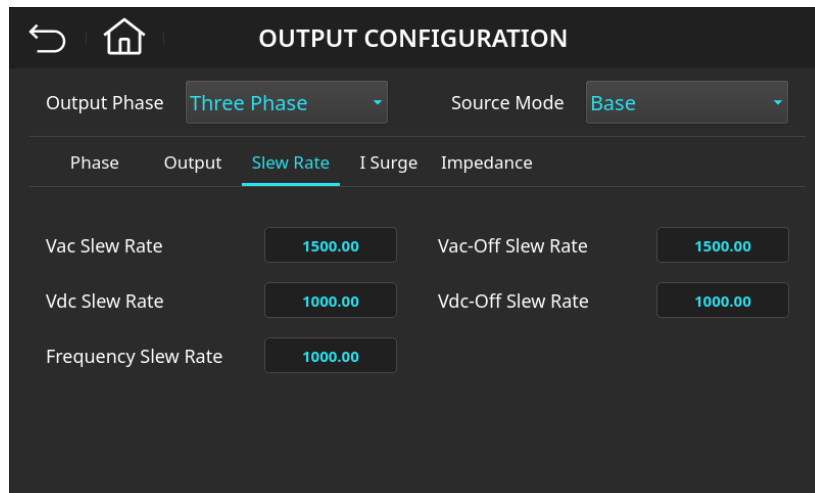

Figure 4-41: Output Slew Rate (Slew Rate) Setting Page

In the regenerative power system, the Output Slew Rate setting controls the rate of change of output voltage (Vac and Vdc) and frequency (Frequency), ensuring a stable transition and preventing excessive transient effects on the device under test (DUT) or the system. Below are the explanations of each Slew Rate setting:

- A. **Vac Slew Rate**: Defines the rate of change of AC voltage during the rising or falling process. By adjusting this parameter, users can control the time it takes for the voltage to transition from one set value to another. This function is particularly important when simulating voltage transients and is suitable for applications that require slow voltage increases or decreases, protecting inductive or capacitive loads from rapid changes.
- B. **Vdc Slew Rate**: Controls the rate of change of DC voltage during startup or shutdown. This adjustment helps prevent excessive transient currents caused by sudden changes in DC voltage, especially when using large capacitive or inductive loads, helping to stabilize the output.
- C. **Frequency Slew Rate**: Adjusts the rate of change of frequency during rising or falling. This function is suitable for applications where frequency changes are sensitive. It allows users to gradually change the

frequency during frequency scanning or switching, avoiding sudden frequency shifts that could cause interference or errors in the system or DUT.

When the regenerative power system is in the OUTPUT ON state, if the user changes the basic output parameters on the main screen in real-time, the changes in output voltage, DC voltage, and frequency will be influenced by the Vac/Vdc/Frequency Slew Rate settings. These settings control the speed at which the output voltage or frequency is adjusted, ensuring the transition is smooth and aligns with the device's response characteristics.

The procedure for setting the Vac Slew Rate = 10.00, Vac-Off Slew Rate = 5.00, and Frequency Slew Rate = 50.00 is as follows:

1. On the Output Configuration page (OUTPUT CONFIGURATION), tap **Slew Rate**.
2. Tap the numeric input field for Vac Slew Rate **1500.00** on the screen.
3. Enter **1**, **0**, then press the **Enter** key. The value will change to "10.00".
4. Tap the numeric input field for Vac-Off Slew Rate **1500.00** on the screen.
5. Enter **5**, then press the **Enter** key. The value will change to "5.00".
6. Tap the numeric input field for Frequency Slew Rate **1000.00** on the screen.
7. Enter **5**, **0**, then press the **Enter** key. The value will change to "50.00", as shown in Figure 4-42.

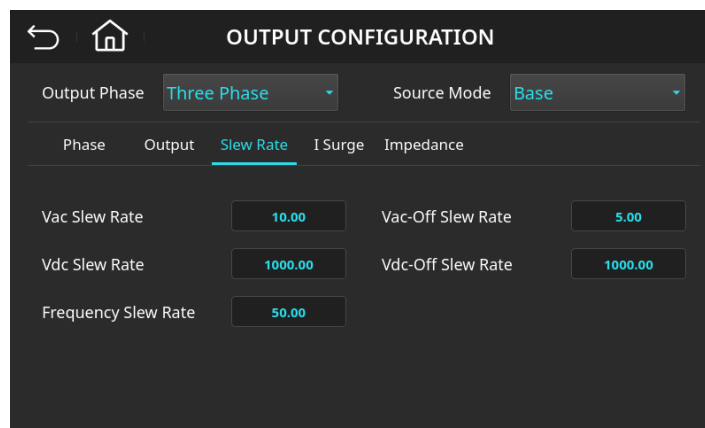

Figure 4-42: Output Slew Rate (Slew Rate) Setting Page

(Vac Slew Rate=10.00, Vac-Off Slew Rate=5.00, Frequency Slew Rate=50.00)

Output Slew Rate (Slew Rate) Parameter Descriptions:

Parameter	Sub-item	Description
Vac Slew Rate	0.01 ~ 2000.00 V/ms	Rate of change in the rise of the Vac output voltage
Vac-Off Slew Rate	0.01 ~ 2000.00 V/ms	Rate of change in the fall of the Vac output voltage
Vdc Slew Rate	0.01 ~ 2000.00 V/ms	Rate of change in the rise of the Vdc output voltage
Vdc-Off Slew Rate	0.01 ~ 2000.00 V/ms	Rate of change in the fall of the Vdc output voltage
Frequency Slew Rate	0.01 ~ 1000.00 Hz/ms	Rate of change in the output frequency

NOTICE

- In the Output Slew Rate parameter settings, Vac Slew Rate, Vdc Slew Rate, and Frequency Slew Rate offer a wide range of input values, allowing flexible adjustments to the rate of change in output voltage and frequency. However, if the set values are too high, the actual output may not fully adhere to the configured rate of change due to hardware limitations or the Response Setting, potentially causing discrepancies in the output.

WARNING

- When Vac Slew Rate and Vdc Slew Rate are set too low, pressing OUTPUT OFF may result in the voltage decay being too slow, causing the voltage to gradually drop to 0V over a prolonged period, potentially lasting several tens of seconds. During this time, the output status in the upper left corner of the main screen will display "Slew-Off", indicating that the voltage is still being output, and the output relay will not disconnect until the voltage has fully dropped to 0V. Users should carefully monitor these settings to avoid prolonged voltage drop times affecting the testing environment.

4.5.6 Inrush Current Measurement Function (Isurge)

In the main menu function page, tap the  function key, then tap  to enter the Inrush Current Measurement Function (Isurge) page, as shown in Figure 4-43.

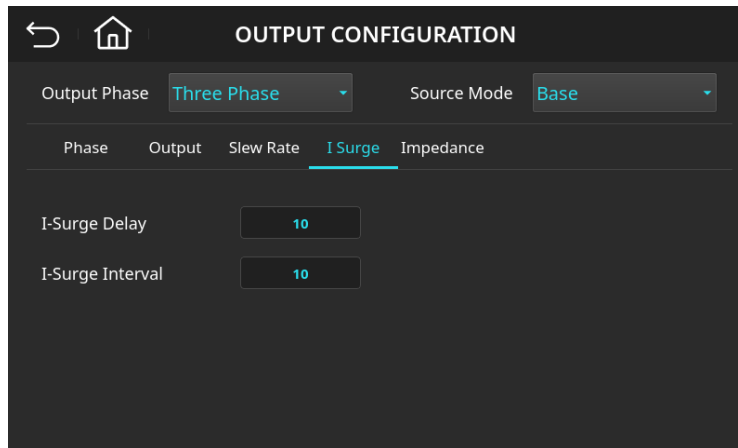

Figure 4-43: Inrush Current Measurement Function (Isurge) Page

In the regenerative power system, the I-Surge Delay and I-Surge Interval parameters are primarily used for inrush current measurement. After the output is activated, the I-Surge Delay setting causes a delay to avoid the immediate inrush current from affecting the measurement results. Then, based on the I-Surge Interval setting, the system measures and displays the maximum output current within that time interval. This data is shown in the I_s parameter on the main screen, allowing users to test and record the inrush current of the device under test (DUT). The measurement procedure is illustrated in Figure 4-44. These settings ensure that the maximum inrush current of the power output is accurately measured and recorded within a specific time range.

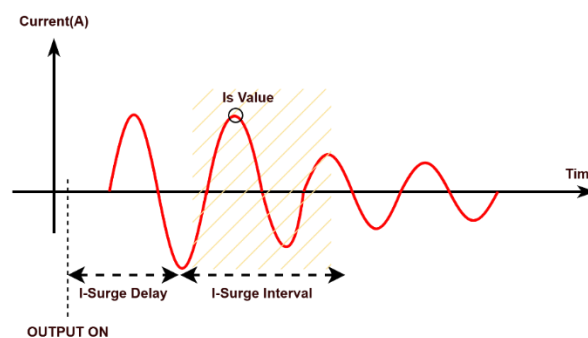

Figure 4-44: Inrush Current Measurement Procedure Diagram

The procedure for setting the inrush current measurement to I-Surge Delay = 50 and I-Surge Interval = 100 is as follows:

1. On the Output Configuration page (OUTPUT CONFIGURATION), tap **I Surge**.
2. Tap the numeric input field for I-Surge Delay **10** on the screen.
3. Enter **5**, **0** then press the **Enter** key. The value will change to "50".
4. Tap the numeric input field for I-Surge Interval **10** on the screen.
5. Enter **1**, **0**, **0**, then press the **Enter** key. The value will change to "100", as shown in Figure 4-45.

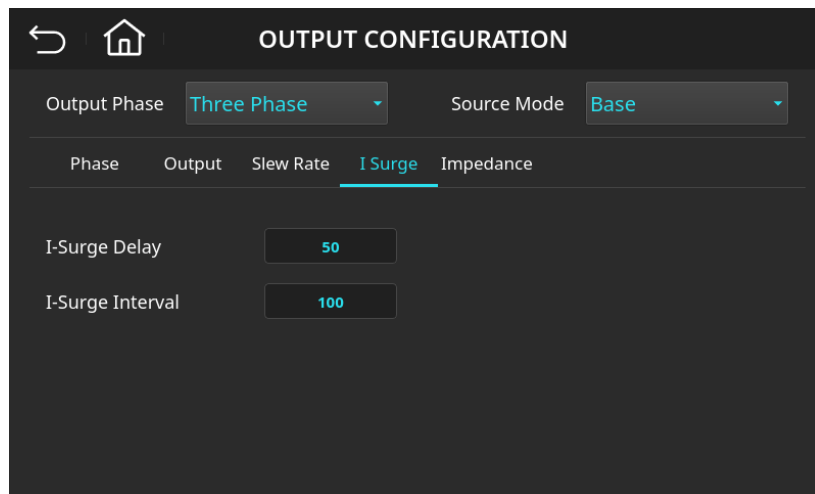

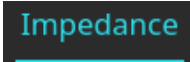

Figure 4-45: Inrush Current Measurement Setting Page (I-Surge Delay = 50, I-Surge Interval = 100)

Inrush Current Measurement (Isurge) Parameter Descriptions:

Parameter	Sub-item	Description
I-Surge Delay	0 ~ 9999 ms	Delay time for inrush current measurement output
I-Surge Interval	0 ~ 9999 ms	Time interval for inrush current measurement output

4.5.7 Programmable Output Impedance (Impedance)

In the main menu function page, tap the  function key, then tap  to enter the Programmable Output Impedance (Impedance) function page, as shown in Figure 4-46.

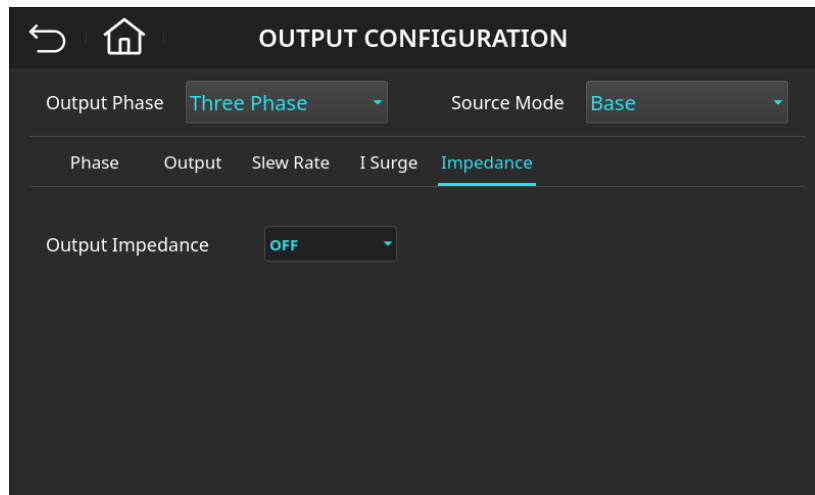

Figure 4-46: Programmable Output Impedance (Impedance) Function Page

The Programmable Output Impedance (Impedance) function allows users to customize the impedance parameters according to the requirements of the device under test (DUT), enabling more accurate simulation of real grid or different power supply environments' impedance characteristics. The main uses of this function include:

- A. **Simulating Realistic Load Conditions:** By setting the resistance and inductance components of the output impedance, users can simulate the behavior of the load under actual power supply impedance conditions, allowing for the observation of the DUT's response under different impedance scenarios.
- B. **Evaluating Stability and Adaptability:** The programmable output impedance helps test the stability of the DUT under various output conditions, especially when impedance changes occur, aiding in the detection of the device's ability to adapt to inrush currents, voltage drops, and other factors.
- C. **Optimizing Test Results:** For devices with special requirements, such as testing inductive or capacitive loads, this function allows for more precise matching of load conditions, improving the accuracy and reliability of the test results.

The procedure for setting the Programmable Output Impedance to $\Phi 1$ R Impedance = 0.5 and $\Phi 1$ L Impedance = 500 is as follows:

1. On the Output Configuration page (OUTPUT CONFIGURATION), tap **Impedance**.
2. Tap the numeric input field for $\Phi 1$ R Impedance **0.500** on the screen.
3. Enter **0**, **.**, **5** then press the **Enter** key. The value will change to "0.5".
4. Tap the numeric input field for $\Phi 1$ L Impedance **500** on the screen.
5. Enter **5**, **0**, **0** then press the **Enter** key. The value will change to "500", as shown in Figure 4-47.

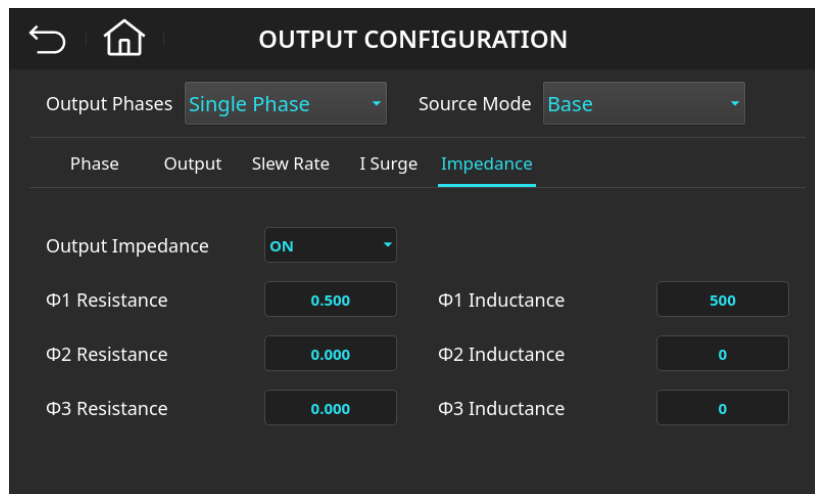

Figure 4-47: Programmable Output Impedance (Impedance) Function Page ($\Phi 1$ R Impedance = 0.5, $\Phi 1$ L Impedance = 500)

Programmable Output Impedance (Impedance) Parameter Descriptions::

Parameter	Sub-item	Description
Output Impedance	<ul style="list-style-type: none"> ■ ON ■ OFF 	Programmable output impedance setting
$\Phi 1$ R Impedance	-1.0 ~ 1.0 Ω	Resistance setting for the first phase output impedance
$\Phi 2$ R Impedance	-1.0 ~ 1.0 Ω	Resistance setting for the second phase output impedance
$\Phi 3$ R Impedance	-1.0 ~ 1.0 Ω	Resistance setting for the third phase output impedance
$\Phi 1$ L Impedance	-1000.0 ~ 1000.0 μH	Inductance setting for the first phase output impedance

Φ2 L Impedance	-1000.0 ~ 1000.0 uH	Inductance setting for the second phase output impedance
Φ3 L Impedance	-1000.0 ~ 1000.0 uH	Inductance setting for the third phase output impedance

NOTICE

- R (Resistance) and L (Inductance) allow negative values, which typically represent the concept of reverse impedance. This simulates the reverse circuit characteristics, altering the system's phase or damping effects. By setting negative impedance, the power supply can generate effects opposite to the transmission line impedance at the output terminal, effectively canceling part of the transmission line's impedance, making the output voltage closer to the ideal value.
- When the Output Impedance function is enabled, the Remote Sense = ON function, mentioned in Chapter 6.2, will be disabled, and the device will not perform remote compensation operations.

4.6 Output Waveform Selection (Wave Select)

The regenerative power system allows users to select the output waveform settings for each phase according to their needs, offering flexibility to handle different load conditions. This design enables users to choose the appropriate waveform configuration based on specific testing conditions and application requirements, facilitating more accurate testing and simulation.

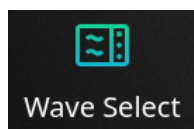



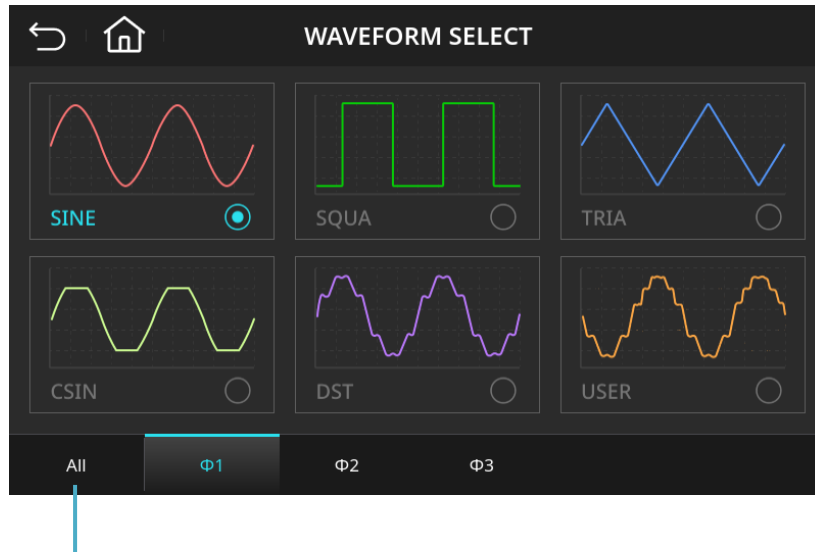

Users can tap the **Wave Select** function key on the main menu function page to enter the Output Waveform Selection (Wave Select) page, which provides the following 6 types of output waveform settings, including Sine Wave (SINE), Square Wave (SQUA), Triangle Wave (TRIA), Clipped Sine Wave (CSIN), 30 Built-in Harmonic Waveforms (DST), and 30 User-defined Waveforms (USER), as shown in Figure 4-48.



Three-Phase Waveform Synchronous Selection

Figure 4-48: Output Waveform Selection (Wave Select) Page

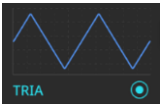
The procedure for setting the three-phase output waveform to Triangle Wave (TRIA) simultaneously is as follows:

1. On the Waveform Select page, tap the icon  in the lower left corner.
2. In the Editing All Phase screen, tap .
3. On the Waveform Select page, tap  and then press . As shown in Figure 4-49, the three-phase output waveforms ($\Phi 1$, $\Phi 2$, $\Phi 3$) have been changed to Triangle Wave (TRIA).

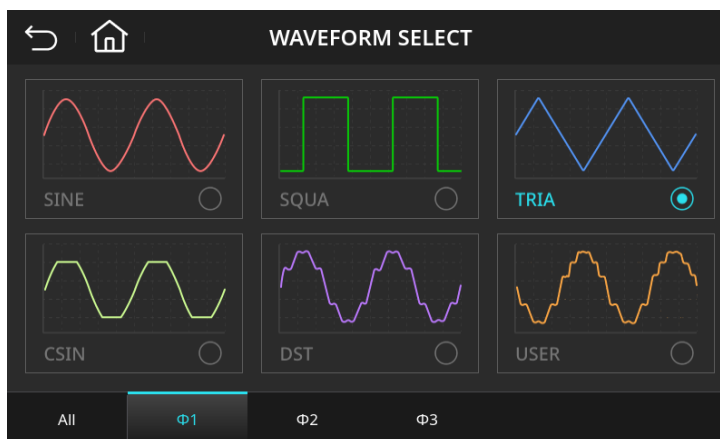
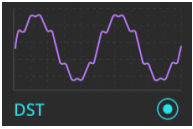





Figure 4-49: Output Waveform Selection Page (Three-Phase Output Waveforms ($\Phi 1$, $\Phi 2$, $\Phi 3$) Set to Triangle Wave (TRIA))

The user sets the output waveform of the third phase to the built-in harmonic (DST1) according to the following procedure.

1. On the Waveform Select page, tap the icon $\Phi 3$ at the bottom of the screen.
2. On the Waveform Select page, tap .
3. Tap the numeric input field for Number  on the screen.
4. Enter  and press the  key. The value will change to "1".
5. Tap  to view the harmonic components of the selected harmonic order.
6. Return to the Waveform Select page. As shown in Figure 4-50, the third-phase output waveform ($\Phi 3$) has been changed to the built-in harmonic waveform (DST1).

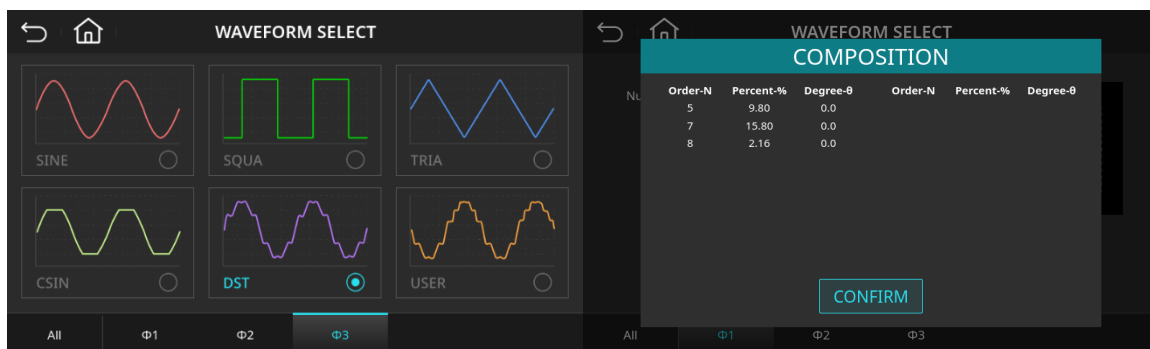



Figure 4-50: Output Waveform Selection Page (Third-Phase Output Waveform ($\Phi 3$) Set to Built-in Harmonic (DST1))

The procedure for setting the first-phase output waveform to Clipped Sine Wave (CSIN) with THD = 20% is as follows:

1. On the Waveform Select page, tap the icon at the bottom of the screen $\Phi 1$.
2. On the Waveform Select page, tap .
3. Tap the dropdown menu for Type  and select "THD".

4. Tap the numeric input field for THD 0.0 on the screen.
5. Enter 2, 0 then press the Enter key. The value will change to “20”.
6. Return to the Waveform Select page. As shown in Figure 4-51, the first-phase output waveform ($\Phi 1$) has been changed to Clipped Sine Wave (CSIN) with THD = 20%.

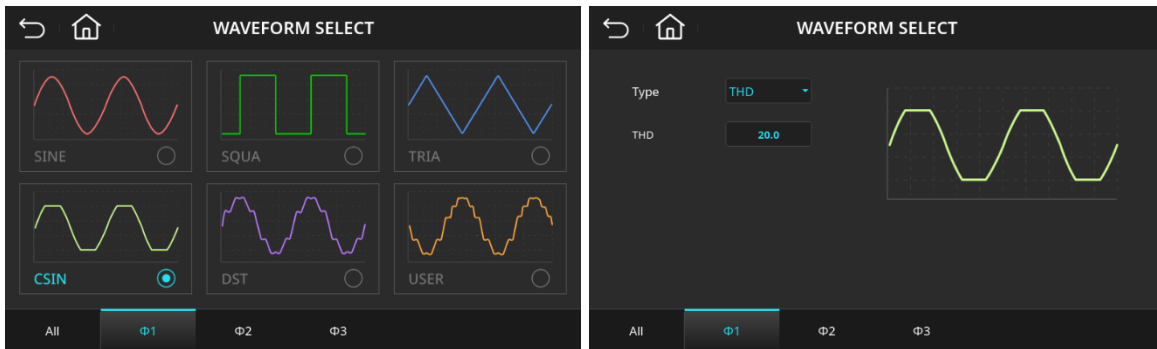

Figure 4-51: Output Waveform Selection Page (First-Phase Output Waveform ($\Phi 1$) Set to Clipped Sine Wave (CSIN), THD = 20%)

Waveform Selection (Wave Select) – Parameter Description:

Parameter	Sub-item	Description
SINE		Sine Wave
SQUA		Square Wave
TRIA		Triangle Wave
CSIN	<ul style="list-style-type: none"> ■ Total Harmonic Distortion (THD): 0.0 ~ 100.0% ■ Amplitude (AMP): 0.0 ~ 43.0% 	Clipped Sine Wave
DST	Please refer to Chapter 10 for details.	Built-in Harmonic Waveforms (30 sets)
USER		User-defined Waveforms (30 sets)
ALL		Three-phase Mode: Synchronized Waveform Selection
$\Phi 1$		Three-phase Mode: Phase 1 Waveform Selection Single-phase Mode: Output Waveform Selection
$\Phi 2$		Three-phase Mode: Phase 2 Waveform Selection
$\Phi 3$		Three-phase Mode: Phase 3 Waveform Selection
$\Phi 12$		Split-phase Mode: Phase 1 vs. Phase 2 Selection

NOTICE

- Clipped Sine Wave (CSIN) settings can be programmed using either Amplitude (AMP) or Total Harmonic Distortion (THD). The amplitude can be set from 0% to 100%, where 100% indicates no clipping or limiting. The THD can be set from 0% to 43%, where 0% means no distortion.
- To set a User-defined waveform (USER), users must either configure the waveform on a remote computer or prepare it in the specified file format (.csv), then load it into the system via a USB flash drive.
- For details on the Built-in Harmonic DST Waveforms, please refer to Chapter 9.

WARNING

- If a User-defined waveform (USER) or a built-in harmonic DST waveform includes high-frequency components that exceed the system's voltage limits, protection mechanisms such as OVP_PEAK or OVP_VR may be triggered.
- Due to the limited bandwidth of the regenerative power system, high-frequency components in a user-defined waveform may result in output waveform distortion.

4.7 System-Wide Parameter Save/Load



In a regenerative power system, the Save/Load function allows users to store the current system configuration as a default file for quick recall later. This function supports saving multiple key system parameters—including output configuration, waveform settings, and protection parameters—into internal memory for easy access during future testing or operation needs.

The Save function enables users to store different configuration schemes, making it convenient to switch quickly between setups for diverse lab requirements. The Load function allows users to retrieve a previously saved configuration file as needed, allowing the system to quickly return to a specific state—greatly improving testing efficiency and reducing the risk of setup errors.

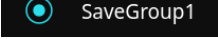

To access the Save/Load page, press the  function key from the main menu. The device provides 6 configuration groups for users. Users can pre-save setups based on different testing needs and use the Load function at any time to quickly switch to the required configuration group, helping save reconfiguration time and ensuring test accuracy and consistency.

The procedure to save system-wide parameters to memory group SaveGroup1 is as follows:

1. On the Save/Load system configuration page, select the first row position .
2. Press , then on the SAVE screen, select . The system will store the current system-wide parameters into memory SaveGroup1, as shown in Figure 4-52.

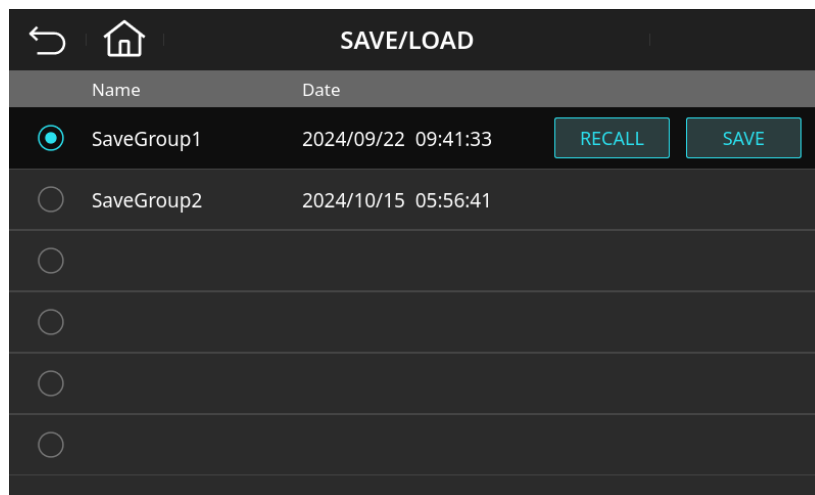



Figure 4-52 System-Wide Parameter Save/Load Page

4.8 Output Protection Settings (Protection)

The protection settings of the regenerative power system are designed to meet the specific requirements of users and their Devices Under Test (DUT), offering multi-level safety assurance. Through flexible configurations such as Overcurrent Protection (OCP), Overpower Protection (OPP), Overvoltage Protection (OVP), Constant Current Control, Constant Power Control, and related delay parameters (e.g., OCP Delay), the system can detect and respond in real time to abnormal conditions, preventing damage caused by overloads or sudden current surges.

This design ensures that users can effectively safeguard both the DUT and system stability under various test conditions, providing enhanced safety and accuracy for the testing environment.

To access the Output Protection Settings page, press the  function key from the main menu, as shown in Figure 4-53.

Simultaneous / Individual
Parameter Editing
Selection

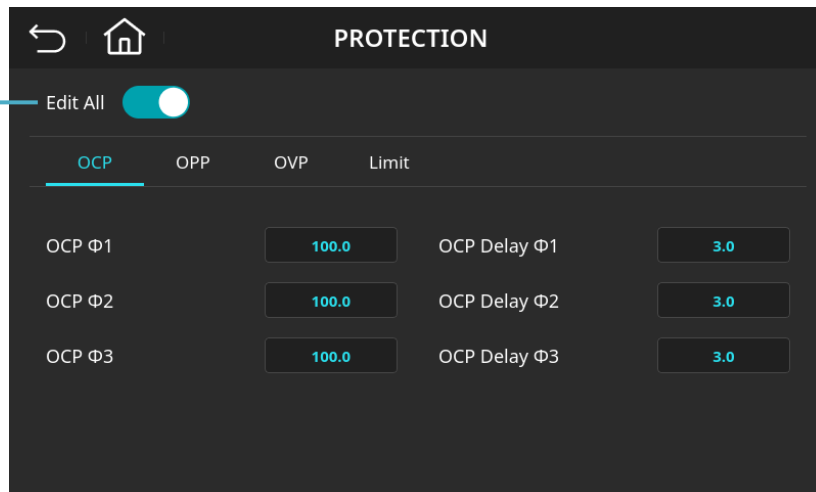



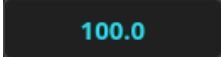



Figure 4-53 Output Protection Settings (Protection) Page

■ Output Overcurrent Protection (OCP)

- A. **O A. OCP (Overcurrent Protection):** This setting is used to limit the output current and prevent damage to equipment and loads due to excessive current. When the output current exceeds the preset value, OCP activates and shuts off the output.

B. **OCP Delay (Overcurrent Protection Delay):** This parameter sets the delay time before OCP activates. If the output current exceeds the OCP set value and continues beyond the specified delay time, the protection will be triggered. This avoids false triggering caused by brief load transients.

The procedure for simultaneously setting the three-phase output overcurrent protection to “OCP $\Phi 1/\Phi 2/\Phi 3 = 50.0$ A, OCP Delay $\Phi 1/\Phi 2/\Phi 3 = 1.0$ s” is described as follows.

1. On the Output Protection Settings (Protection) page, tap  on the screen.
2. Tap to enable the Edit All function key .
3. Tap the numeric input field for OCP $\Phi 1$ .
4. Enter , then press  to change the value to “50.0”.
5. Tap the numeric input field for OCP Delay $\Phi 1$ .
6. Enter , then press  to change the value to “1.0”, as shown in Figure 4-54.

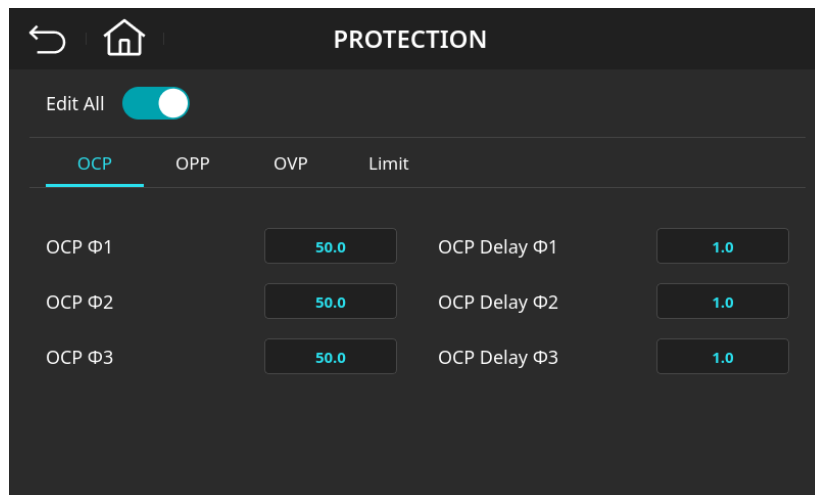

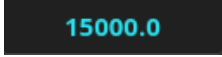



Figure 4-54 Output Overcurrent Protection Page (OCP $\Phi 1/\Phi 2/\Phi 3 = 50.0$ A, OCP Delay $\Phi 1/\Phi 2/\Phi 3 = 1.0$ s)

■ Output Overpower Protection (OPP)

OPP (Overpower Protection): OPP is used to limit the output power to prevent overload from damaging the system or the Device Under Test (DUT). When the output power exceeds the preset protection value, the system will trigger OPP and shut down the output.

The procedure for setting the Phase 1 output overpower protection to “OPP Φ 1 = 10000.0 VA” is described as follows:

1. On the Output Protection Settings (Protection) page, tap  on the screen.
2. Tap to disable the Edit All function key .
3. Tap the numeric input field for OPP Φ 1 .
4. Enter 1, 0, 0, 0, 0 then press  to change the value to “10000.0”, as shown in Figure 4-55.

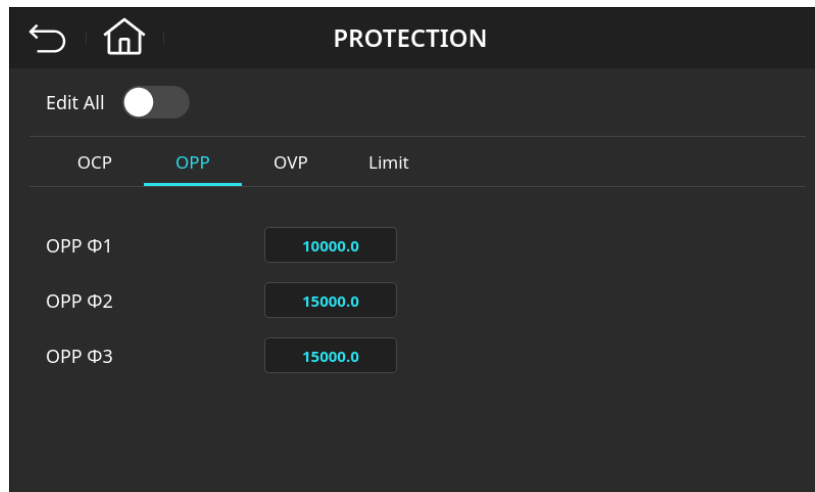





Figure 4-55 Output Overpower Protection Page (OPP Φ 1 = 10000.0 VA)

■ Output Overvoltage Protection (OVP)

OVP (Overvoltage Protection): OVP is designed to protect equipment from damage caused by excessive voltage. When the output voltage exceeds the set value, the system will activate overvoltage protection to prevent high voltage from affecting the DUT or internal system components.

The procedure for setting Phase 1 output overvoltage protection to “OVP-Peak Φ 1 = 350 V” is described as follows:

1. On the Output Protection Settings (Protection) page, tap  on the screen.
2. Tap to disable the Edit All function key .
3. Tap the numeric input field for OVP-Peak Φ 1 .
4. Enter 3, 5, 0 then press  to change the value to “350.0”, as shown in Figure 4-56.

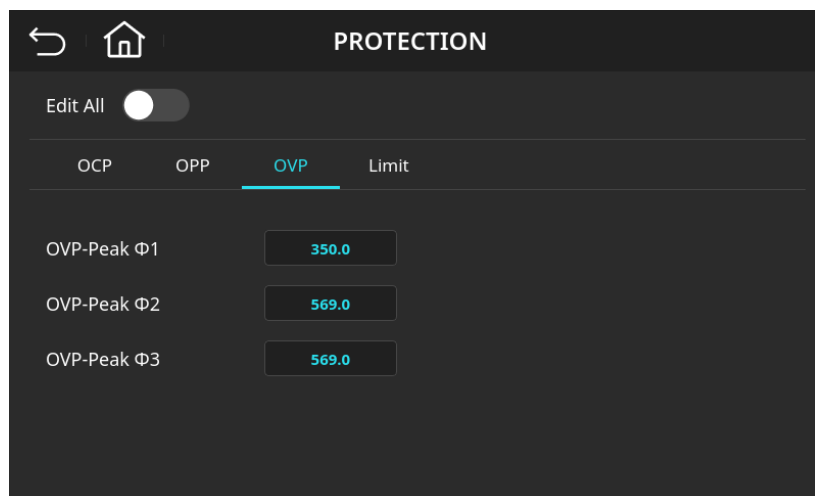

Figure 4-56 Output Overvoltage Protection Page (OVP-Peak Φ 1 = 350 V)

■ Output Constant Current / Power Control (Current/Power Limit Control)

The **Current Limit Control function** ensures that when the regenerative power system detects output current exceeding a preset limit during testing, the device automatically reduces the output voltage to keep the current within the defined range. At this point, the power supply switches to Constant Current Mode, maintaining the output current at the set value to avoid potential damage to either the DUT or the power device itself. This current clamping feature enhances both test safety and DUT stability.

The **Power Limit Control function** operates on a similar principle. When the output power exceeds the configured limit, the system adjusts the output voltage to keep the power within the set limit. Under this mode, once the power reaches the upper limit, the power supply automatically decreases output voltage to prevent overload. This characteristic allows the system to remain stable during overpower conditions and protects both the DUT and the equipment from potential damage.

The procedure for simultaneously setting the three-phase current/power limit protection to “Current Limit $\Phi 1/\Phi 2/\Phi 3 = 35.0$ A, Power Limit $\Phi 1/\Phi 2/\Phi 3 = 10000.0$ VA” is described as follows:

1. On the Output Protection Settings (Protection) page, tap **Limit** on the screen.
2. Tap to enable the Edit All function key **Edit All**.
3. Tap the dropdown menu for Current Limit Control **Disable**, and select “Enable”.
4. Tap the numeric input field for Current Limit $\Phi 1$ **100.0**.
5. Enter **3**, **5** then press **Enter** to change the value to “35.0”.
6. Tap the dropdown menu for Power Limit Control **Disable**, and select “Enable”.
7. Tap the numeric input field **15000.0** for Power Limit $\Phi 1$.
8. Enter **1**, **0**, **0**, **0**, **0** then press **Enter** to change the value to “10000.0”, as shown in Figure 4-57.

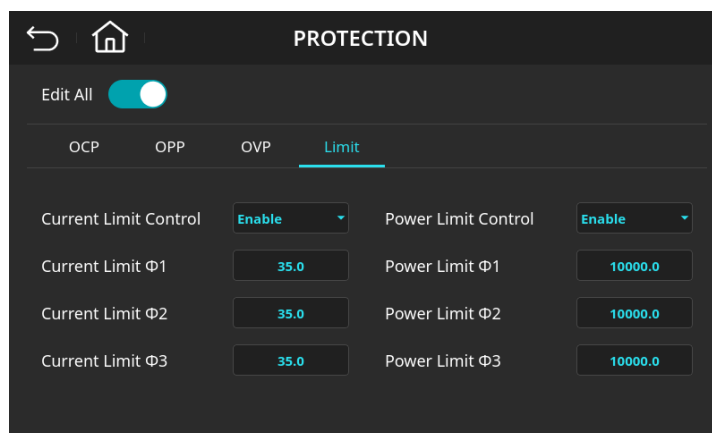

Figure 4-57 Output Current/Power Limit Protection Page (Current Limit $\Phi 1/\Phi 2/\Phi 3 = 35.0$ A, Power Limit $\Phi 1/\Phi 2/\Phi 3 = 10000.0$ VA)

Output Protection Settings (Protection) – Parameter Description:

Parameter	Sub-item	Description
OCP	<ul style="list-style-type: none"> ■ OCP Φ1 : 0.1 ~ 102.0 A ■ OCP Φ2 : 0.1 ~ 102.0 A ■ OCP Φ3 : 0.1 ~ 102.0 A ■ OCP Delay Φ1 : 0.0 ~ 5.0 s ■ OCP Delay Φ2 : 0.0 ~ 5.0 s ■ OCP Delay Φ3 : 0.0 ~ 5.0 s 	Output Overcurrent Protection
OPP	<ul style="list-style-type: none"> ■ OPP Φ1 : 0.1 ~ 15300.0 VA ■ OPP Φ2 : 0.1 ~ 15300.0 VA ■ OPP Φ3 : 0.1 ~ 15300.0 VA 	Output Overpower Protection
OVP	<ul style="list-style-type: none"> ■ OVP-Peak Φ1 : 5.0 ~ 569.0 V ■ OVP-Peak Φ2 : 5.0 ~ 569.0 V ■ OVP-Peak Φ3 : 5.0 ~ 569.0 V 	Output Overvoltage Protection
Limit	<ul style="list-style-type: none"> ■ Current Limit Control : Enable/Disable ■ Current Limit Φ1 : 1.0 ~ 102.0 A ■ Current Limit Φ2 : 1.0 ~ 102.0 A ■ Current Limit Φ3 : 1.0 ~ 102.0 A ■ Power Limit Control : Enable/Disable ■ Power Limit Φ1 : 1.0 ~ 15300.0 VA ■ Power Limit Φ2 : 1.0 ~ 15300.0 VA ■ Power Limit Φ3 : 1.0 ~ 15300.0 VA 	Constant Current / Power Output Function

NOTICE

- The protection setting ranges described here are based on the specifications of the RPS-5045 (45 kVA) model. If you are using a different model from the same series, please refer to Section 1.4 – Specifications for the corresponding protection ranges and parameter differences.
- The delay time setting for current protection is only valid within the output current range specified by the device.
- When both Current Limit Control and Power Limit Control functions are enabled, the system will prioritize the first limit value reached and control based on that threshold.

4.9 Information

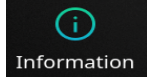
Users can access the **System Information** page by selecting the function key  on the main menu screen, as shown in Figure 4-58. This page provides essential device information, including product model, serial number, firmware version, and optional features. It allows users to verify device specifications, track version status, and support future maintenance and technical management tasks.

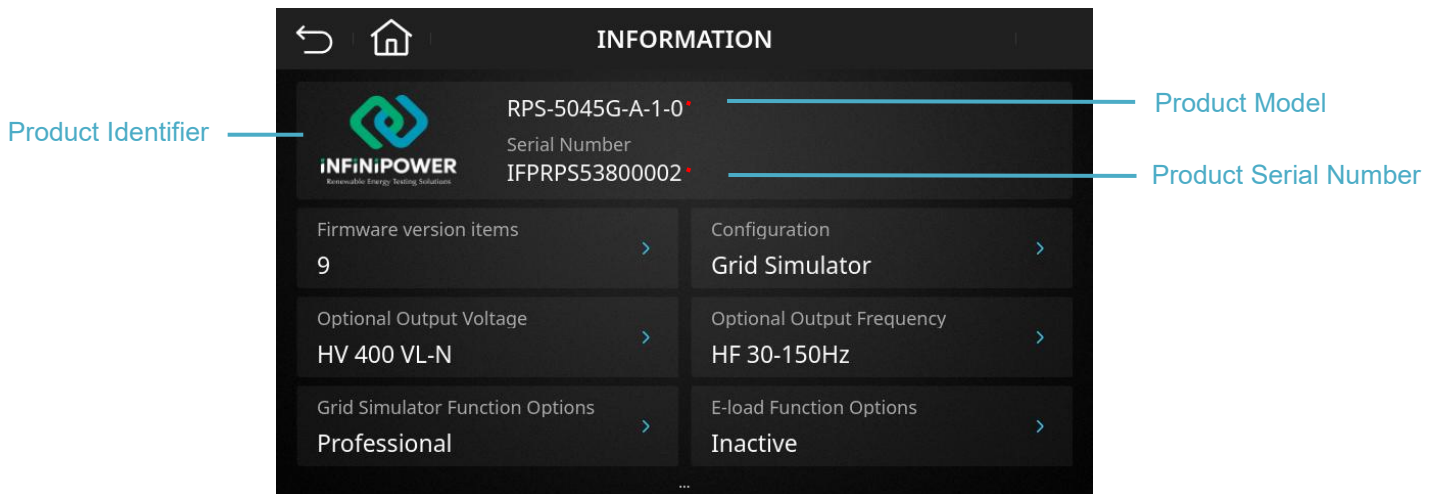

Figure 4-58 System Information (Information) Page

On the System Information page, users can select the Firmware Version item. By turning the rotary knob clockwise, they can view the detailed firmware version of the device, as shown in Figure 4-59.

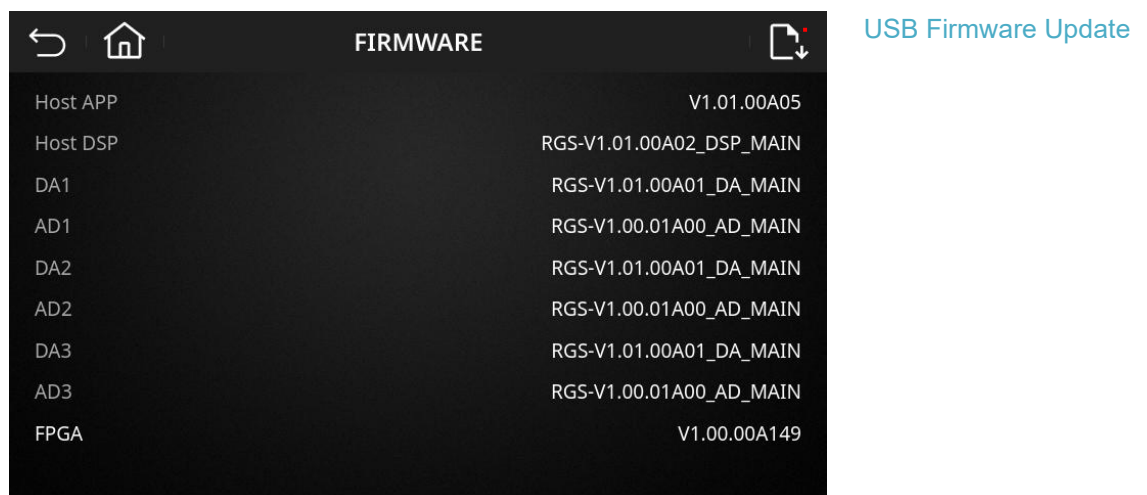

Figure 4-59 System Firmware Version Page

NOTICE

- This device supports firmware updates via USB flash drive. Users can perform the upgrade through the front panel USB port. The update must use a dedicated file format (.bin) provided by InfiniPower or an authorized distributor to ensure file integrity and system compatibility.

System Information (Information) Parameter Descriptions:

Parameter	Sub-Item	Description
Product Logo		Product identifier/logo
Product Number		Device model number
Series Number		Device serial number
Firmware version items	<ul style="list-style-type: none"> ■ Host APP ■ Host DSP ■ DA1 ■ AD1 ■ DA2 ■ AD2 ■ DA3 ■ AD3 ■ FPGA 	Firmware Version Item
Configuration	<ul style="list-style-type: none"> ■ AC/DC Source ■ Grid Simulator ■ E-Load ■ Grid Simulator + E-Load 	Product Configuration
Optional Output Voltage	<ul style="list-style-type: none"> ■ Standard(350VL-N) ■ HV 400VL-N 	Optional Output Voltage
Optional Output Frequency	<ul style="list-style-type: none"> ■ Standard(30-150Hz) ■ HF 30-1000Hz 	Optional Output Frequency
Grid Simulator Function Options	<ul style="list-style-type: none"> ■ Standard ■ Professional 	Grid Simulator Function Option
E-load Function Options	<ul style="list-style-type: none"> ■ Standard ■ Professional 	Electronic Load Function Option

5 Advanced Mode Setting

The regenerative power system is equipped with powerful programmable advanced modes designed to meet a wide range of testing requirements. Users can flexibly switch between modes based on real-world test scenarios. The system supports multiple operating modes that accurately simulate real application conditions, including voltage fluctuations and sags, power cycle interruptions, frequency drift, and surges, significantly enhancing test realism and comprehensiveness. Additionally, the system supports Power Line Disturbance (PLD) simulation, allowing users to replicate various nonlinear load characteristics and complex power disturbance conditions. This ensures effective adaptation to diverse DUT (Device Under Test) requirements.

The system is suitable for a broad range of testing applications—from stress tolerance tests to performance response evaluations—providing precise and controllable power conditions. By leveraging these advanced modes, users can ensure the stability and reliability of DUT testing under dynamic operating conditions.

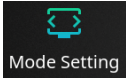
From the main menu function page, press the  function key to enter the Advanced Mode Setting page (Mode Setting), as shown in Figure 5-1.

Mode options include Base Mode, List Mode, Step Mode, Pulse Mode, Synthesis Mode, Interharmonic Mode, and Transient Mode.

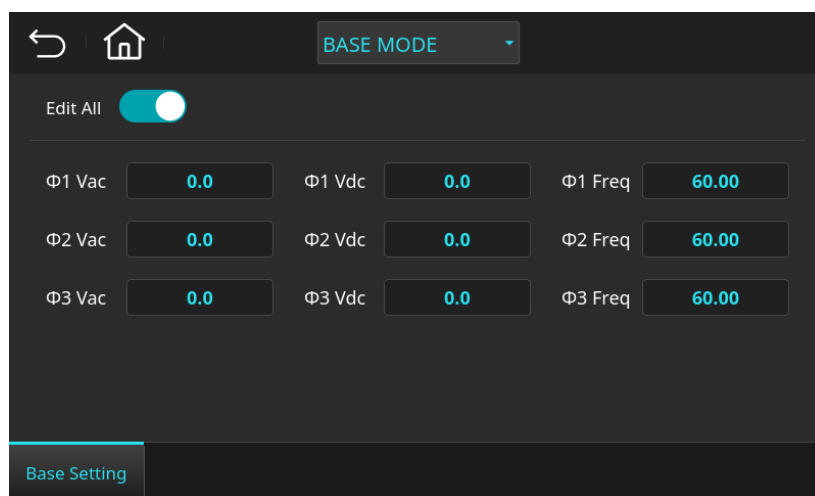

Figure 5-1 Advanced Mode Setting (Mode Setting) Page

Advanced Mode Setting (Mode Setting) – Parameter Description:

Parameter	Sub-item	Description
Base	Refer to Section 5.1	Base Mode
List	Refer to Section 5.2	List Mode
Step	Refer to Section 5.3	Step Mode
Pulse	Refer to Section 5.4	Pulse Mode
Synthesis	Refer to Section 5.5	Waveform Synthesis Mode
Interharmonic	Refer to Section 5.6	Interharmonic Mode
Transient	Refer to Section 5.7	Transient Waveform Mode

⚠ WARNING

- In Advanced Mode Setting, pressing the TRIG. function key will directly activate the configured mode and start output, equivalent to triggering the OUTPUT ON function. During operation, users should pay close attention to the system status to ensure safe operation..

5.1 Base Mode (Base)

From the Advanced Mode Setting (Mode Setting) page, press **BASE MODE** to open the dropdown menu, and select “Base Mode” to enter Base Mode, as shown in Figure 5-1.

Base Mode provides stable and continuous voltage output and is the best choice for general testing. Users can set and maintain a specific voltage and frequency, suitable for basic electrical performance inspection.

Base Mode – Parameter Description:

Parameter	Sub-item	Description
Edit All	ON, OFF	Simultaneous / Individual Parameter Editing Selection
Φ1 / Φ2 / Φ3 Vac	0.0 ~ 350.0 V	Three-phase AC output voltage setting parameters
Φ1 / Φ2 / Φ3 Vdc	-495.0 ~ 495.0 V	Three-phase DC output voltage setting parameters
Φ1 / Φ2 / Φ3 Freq	30.0 ~ 150.0 Hz	Three-phase frequency output setting parameters

5.2 List Mode (List)

The List Mode provides a programmable waveform sequence that allows precise control over the output order and parameters of each phase. This mode enables users to set a series of predefined parameters such as voltage, frequency, and phase, and output them in a specified order and time interval. Through List Mode, users can simulate dynamic power conditions such as surges, sags, and frequency shifts. This mode is ideal for simulating continuously changing test conditions in specific applications, such as power transitions or device endurance tests. It meets the DUT's needs under various test scenarios, significantly enhancing the flexibility and accuracy of testing.

From the Advanced Mode Setting (Mode Setting) page, press **BASE MODE** to open the dropdown menu, and select "LIST MODE" to enter List Mode, as shown in Figure 5-2.

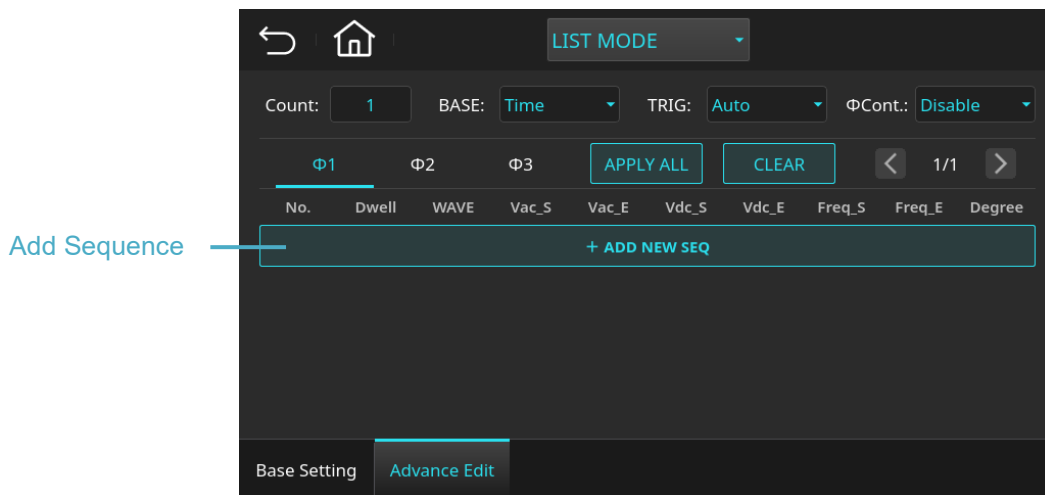

Figure 5-2 List Mode Setting Page

On the List Mode page, tapping **+ ADD NEW SEQ** allows you to add a new sequence. After selecting a specific sequence, the related editable parameters will be displayed, as shown in Figure 5-3. Then, tap **EDIT** again to enter the sequence design page for detailed editing, as shown in Figure 5-4.

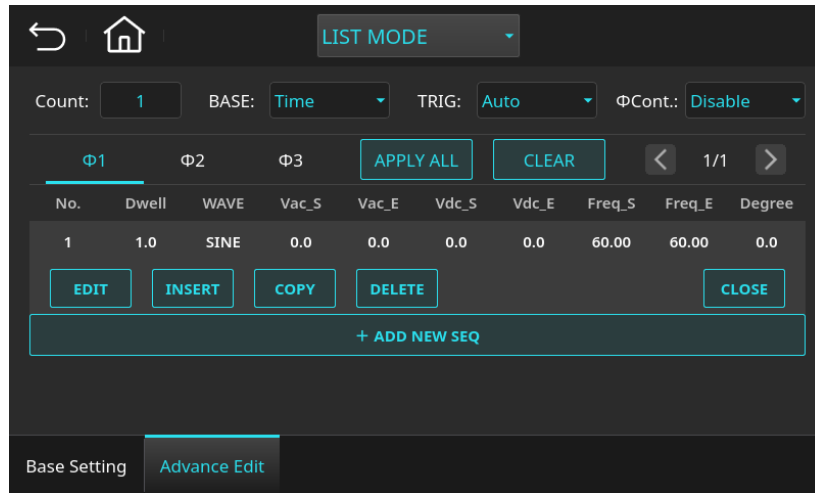

Figure 5-3 List Mode Setting Page (Add Phase 1 – Sequence 1)

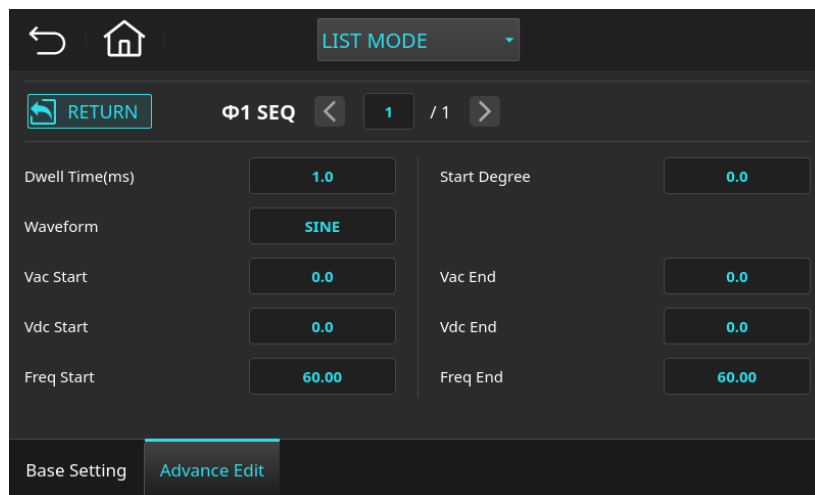





Figure 5-4 List Mode Setting Page (Phase 1 – Sequence 1 Configuration Page)

■ Press TRIG. ON to Execute List Mode (List)

After configuring the sequence, tap the Home key  to exit the List Mode editing page. At this point,

press  to trigger the output. The output status will appear in green text as ,

indicating that the regenerative power system is currently executing the List Mode output (see Figure 5-5). To

stop List Mode output, the user can press  to halt the process. When the system completes all sequences

and the specified number of cycles, the main screen will display **LIST MODE**, indicating the OUTPUT OFF status—i.e., no output is active, as shown in Figure 5-6.

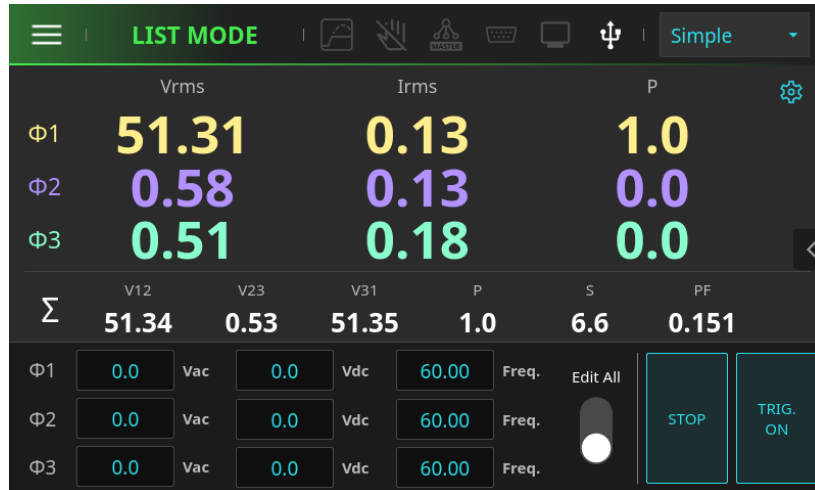

Figure 5-5 Three-Phase Mode Main Screen (List Mode Output Status)

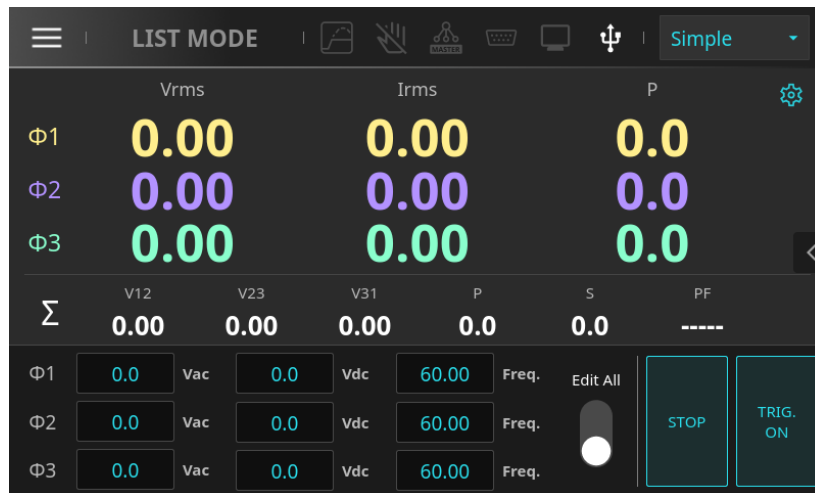



Figure 5-6 Three-Phase Mode Main Screen (List Mode Standby Status)

■ Execute List Mode (List) by Pressing TRIG. ON During Output Operation

When the regenerative power system is in operation, pressing the OUTPUT OFF key will reduce the output voltage to 0V and immediately stop the output. If OUTPUT ON is pressed again, the system will only output the basic parameter settings shown on the main screen (i.e., Base Mode). To restart List Mode, the user must press

TRIG. ON to trigger it. This allows the user to activate List Mode at any time while in the OUTPUT ON state, making operation more convenient.

An example of configuring Phase 1 in List Mode (List) by the user is described as follows.

1. On the List Mode page, select **Φ1**, then tap **+ ADD NEW SEQ** on the screen to add three sequences.
2. Set Count = 1, BASE = Time, TRIG = Auto, ΦCont. = Disable.
3. Select Φ1 SEQ1, tap the Edit button **EDIT**, and edit the parameters as shown in Figure 5-7.
4. Select Φ1 SEQ2, tap the Edit button **EDIT**, and edit the parameters as shown in Figure 5-8.
5. Select Φ1 SEQ3, tap the Edit button **EDIT**, and edit the parameters as shown in Figure 5-9.
6. Press **RETURN** to confirm the List Mode setting page, as shown in Figure 5-10.
7. After setting the sequences, tap the Home key , then press **TRIG. ON** to trigger the output. The output waveform is shown in Figure 5-11.

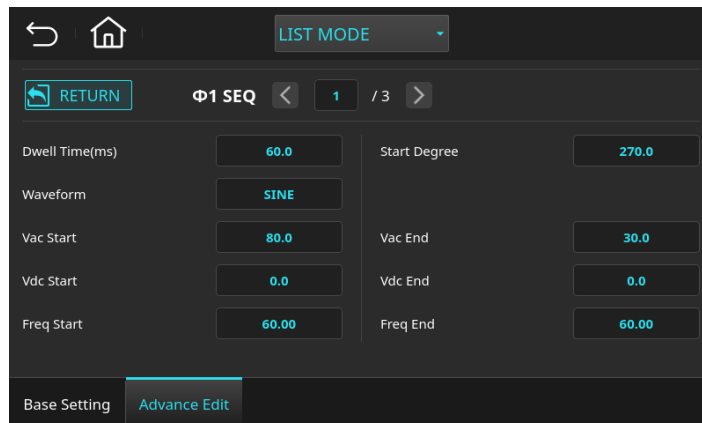

Figure 5-7 List Mode Setting Page (Example Parameters for Phase 1 – Sequence 1)

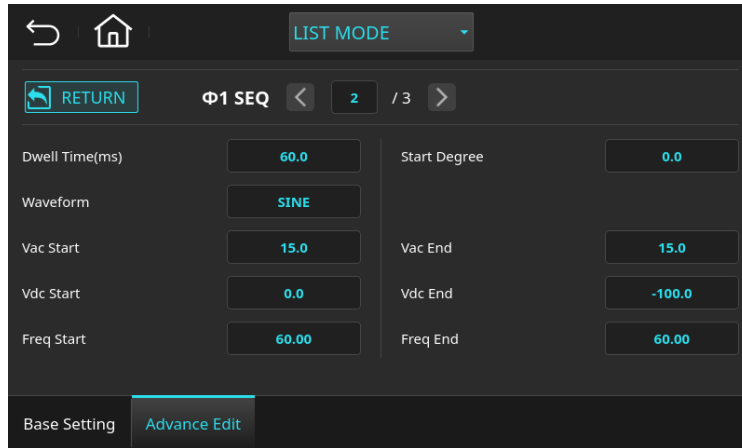

Figure 5-8 List Mode Setting Page (Example Parameters for Phase 1 – Sequence 2)

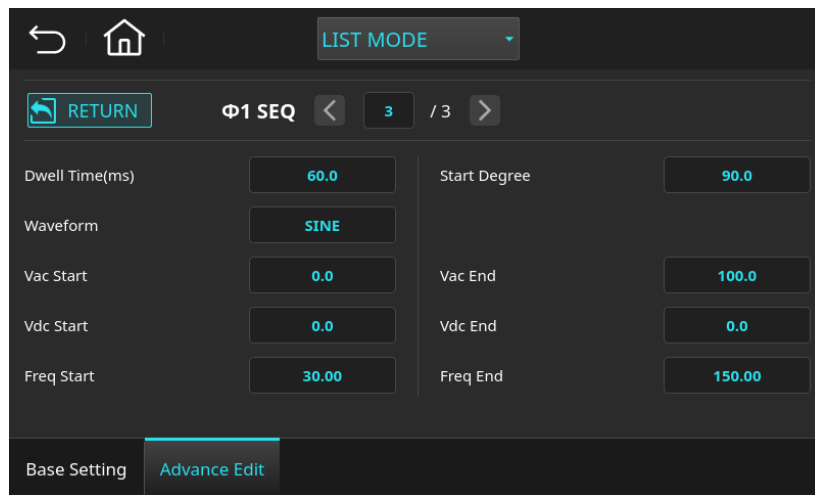

Figure 5-9 List Mode Setting Page (Example Parameters for Phase 1 – Sequence 3)

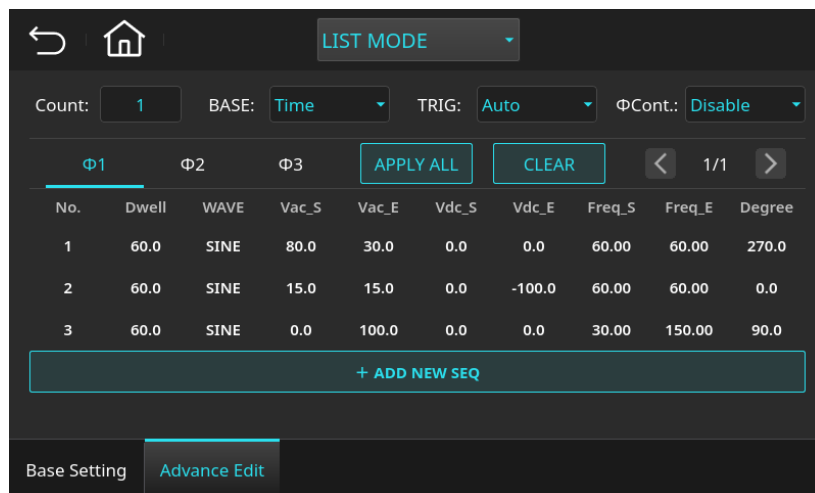

Figure 5-10 List Mode Setting Page (Example Parameters for Phase 1 Sequence Configuration)

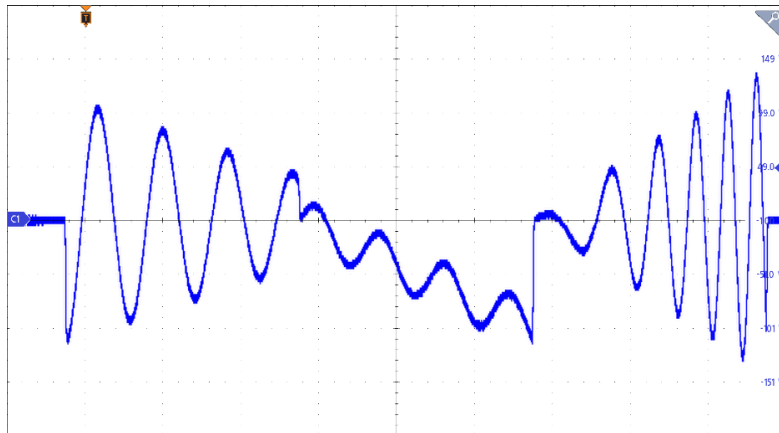

Figure 5-11 List Mode Setting Page (Example Output Waveform for Phase 1 Sequence Configuration)

If the user applies the above example for Phase 1 in List Mode (List) and sets “ΦCont. = Enable”, the resulting waveform is shown in Figure 5-12.

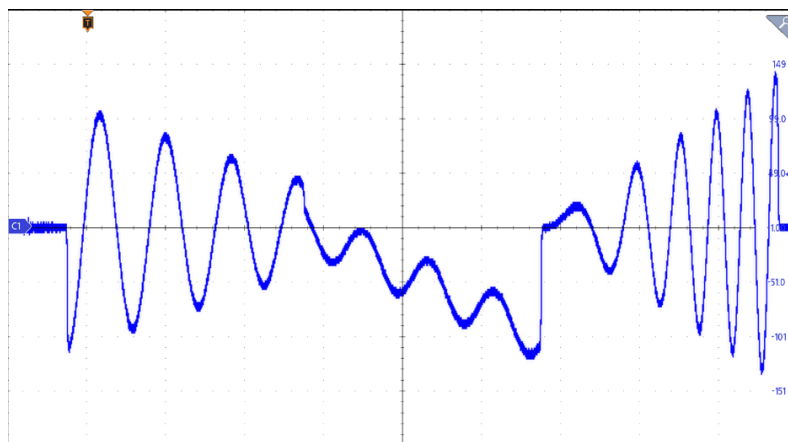

Figure 5-12 List Mode Setting Page (Example Output Waveform for Phase 1 Sequence Configuration, ΦCont. = Enable)

List Mode Parameter Description:

Parameter	Sub-item	Description
Count	1 ~ 99999, 0=Continuous	Number of times the sequence will be executed. When set to 0, the system will loop the sequence indefinitely.
BASE	<ul style="list-style-type: none"> ■ Cycle ■ Time 	Cycle: Sequence length is measured in cycles. Time: Sequence length is measured in time units.
TRIG	<ul style="list-style-type: none"> ■ Auto ■ Manual ■ Excite 	Auto: Automatically runs the sequence the number of times defined by Count. Manual: Executes the sequence once; equivalent to Count = 1. Excite: Uses an external trigger signal via External I/O pin 15 (/Remote-Excite) to start the sequence.
ΦCont.	<ul style="list-style-type: none"> ■ Enable ■ Disable 	Enable: Each sequence starts from the final phase angle of the previous sequence, ignoring the start angle of the current one. Disable: Each sequence (SEQ) follows its own configured start angle.

$\Phi 1 / \Phi 2 / \Phi 3$		Opens the List Mode setting page for the selected phase ($\Phi 1 / \Phi 2 / \Phi 3$).
APPLY ALL		Applies the selected phase's configuration parameters to all phases.
CLEAR		Clears the configuration parameters of the selected phase.
ADD NEW SEQ		Adds a new sequence.
EDIT		Edits the selected sequence.
INSERT		Inserts a new sequence above the selected one.
COPY	–	Copies the selected sequence and inserts it above the current one with the same parameter settings.
DELETE	–	Deletes the selected sequence.
CLOSE	–	Closes the selected sequence.
Cycle Count	1 ~ 9999	When BASE = Cycle, sets the number of cycle repetitions for the sequence.
Dwell Time (ms)	0.1 ~ 99,999,999.9	When BASE = Time, sets the duration of the sequence in milliseconds.
Start Degree	0.0 ~ 359.9 deg	Sets the starting phase angle for the sequence.
Waveform	Refer to Section 4.6	Selects the waveform for the sequence.
Vac Start / End	0.0 ~ 350.0 V	Sets the start and end values of AC voltage for the sequence.
Vdc Start / End	-495.0 ~ 495.0 V	Sets the start and end values of DC voltage for the sequence.
Freq Start / End	30.0 ~ 150.0 Hz	Sets the start and end frequency values for the sequence.

NOTICE

- For details on the pin functions and specifications of the External I/O terminal, please refer to Chapter 12 of this manual.
- In List Mode, waveform programming is composed of multiple sequences. The output waveform will start from Sequence = 1 and execute each subsequent sequence in order. In Three-Phase Mode, if the Time or Cycle settings differ between phases, the system will follow the phase with the longest configured time or cycle. The other phases will remain at 0V during that time. This design helps prevent operational errors or test inaccuracies, ensuring system stability and test precision.

5.3 Step Mode (Step)

Step Mode provides a convenient automatic switching function that enables the output voltage to quickly switch between defined steps, changing the voltage in discrete increments. Users can configure the initial voltage, step dwell time, voltage increment per step, and the number of steps, executing them in a programmed sequence.

After execution is completed, the output voltage will remain at the value set in the final step. This mode is ideal for tests that require rapid transitions between different voltage levels, allowing simulation of various power fluctuation scenarios to evaluate the DUT's response and performance.

From the Advanced Mode Setting (Mode Setting) page, press **BASE MODE** to open the dropdown menu, then select "STEP MODE" to enter Step Mode, as shown in Figure 5-13.

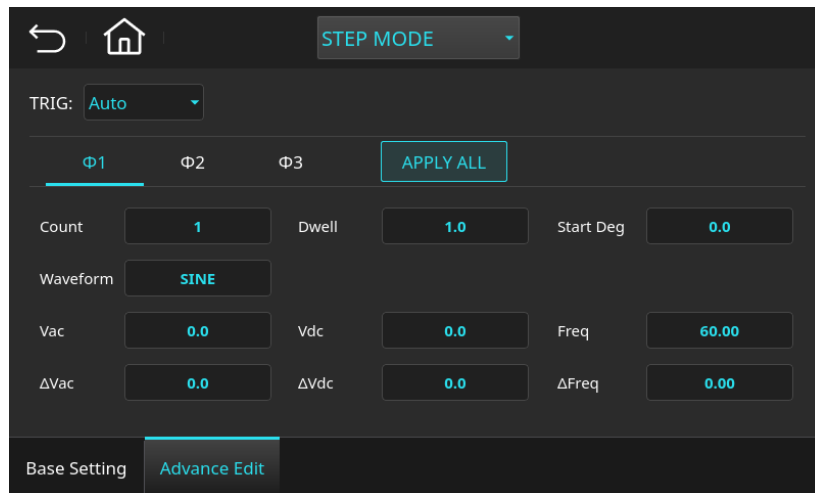



Figure 5-13 Step Mode Setting Page

■ TRIG = Auto: Press TRIG. ON to execute Step Mode (Step)

After setting the parameters, tap the Home key  to exit the Step Mode (Step) editing page. At this point, press **TRIG. ON** to trigger the output. The output status will be shown in green text **STEP MODE**, indicating that the regenerative power system is executing the Step Mode output (see Figure 5-14). After pressing the

PAUSE key, the system will maintain the current step's output waveform. Only when **CONTINUE** is pressed again will the waveform continue and proceed to the next step. To stop the Step Mode output, the user can press **STOP**. Once the system completes the set number of cycles, the main screen will display **STEP MODE**, indicating the OUTPUT OFF state, i.e., no output is active (see Figure 5-15).

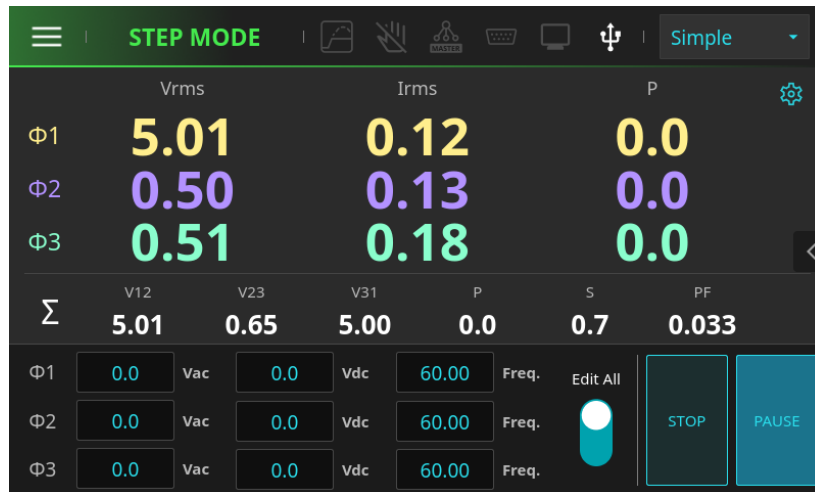

Figure 5-14 Main Screen in Three-Phase Mode (Step Mode Output Status)

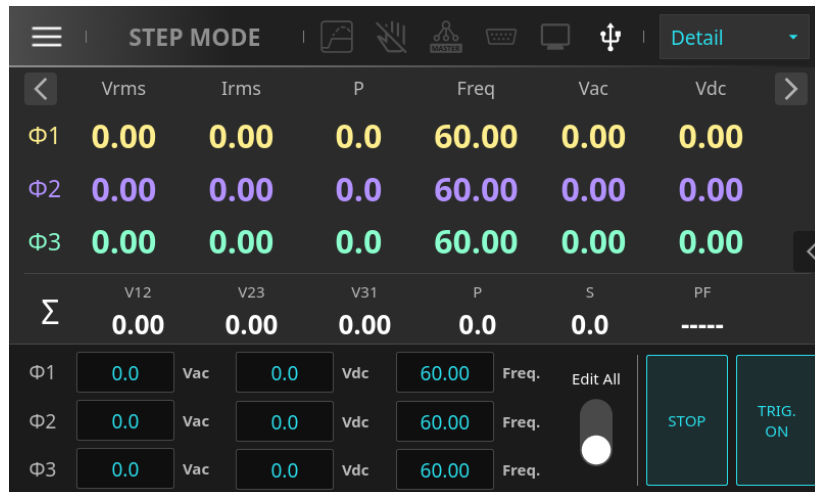

Figure 5-15 Three-Phase Mode Main Screen (Step Mode Standby Status)

■ **TRIG = Manual: Press TRIG. UP / DOWN to execute Step Mode (Step)**

When the trigger mode is set to Manual, the lower right corner of the main screen will display the options

TRIG. UP and **TRIG. DOWN**, as shown in Figure 5-16. When “TRIG. UP” is selected, the output waveform will change to the

current voltage plus the step increment. If “TRIG. DOWN” is selected, the output waveform will change to the current voltage minus the step increment.

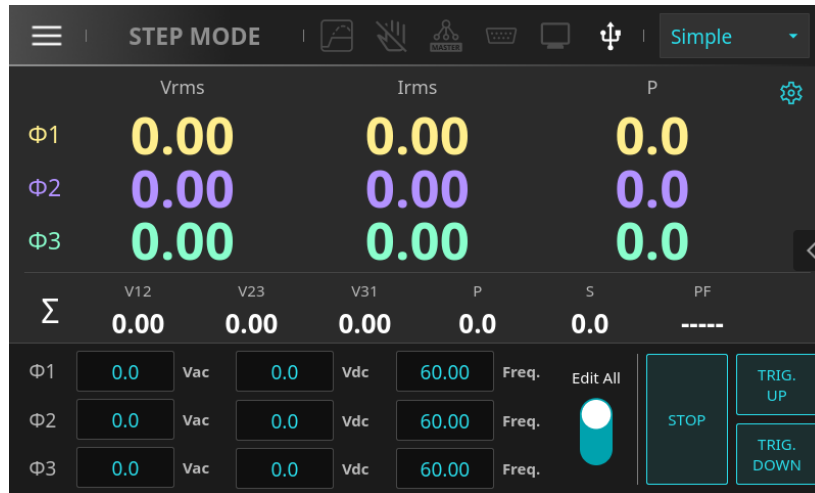



Figure 5-16 Three-Phase Mode Main Screen (Step Mode Standby Status, TRIG = Manual)

■ Execute Step Mode (Step) During Output Operation by Pressing TRIG.

When the regenerative power system is in operation, pressing the OUTPUT OFF key will reduce the output voltage to 0V and immediately stop the output. If OUTPUT ON is pressed again, the system will only output the basic parameter settings shown on the main screen (i.e., Base Mode). To restart Step Mode, the user must press

TRIG. ON or **TRIG. UP** / **TRIG. DOWN** to trigger it. This allows users to activate Step Mode at any time while in the OUTPUT ON state, making operation more convenient.

An example of configuring Phase 1 in Step Mode (Step) by the user is described as follows.

1. On the Step Mode (Step) page, select **Φ1**.
2. Set TRIG = Auto, and edit the parameters as shown in Figure 5-17.
3. After setting the parameters, tap the Home key , then press **TRIG. ON** to trigger the output. The output waveform is shown in Figure 5-18.

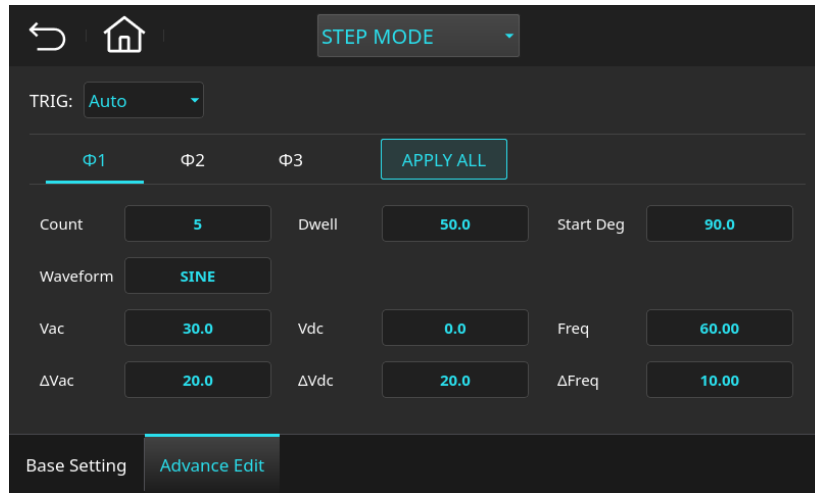

Figure 5-17 Step Mode Setting Page (Example Parameters for Phase 1)

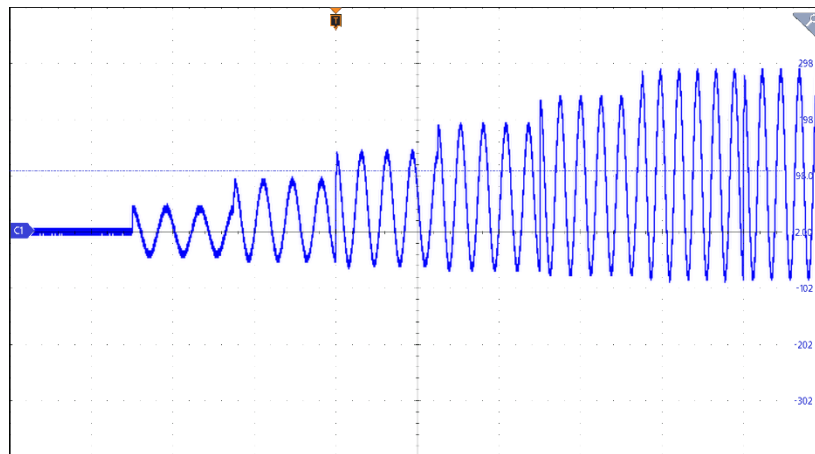

Figure 5-18 Step Mode Setting Page (Example Output Waveform for Phase 1)

Step Mode – Parameter Description:

Parameter	Sub-item	Description
TRIG	<ul style="list-style-type: none"> ■ Auto ■ Manual ■ Excite 	Auto: Automatically executes all steps according to the set Count value. Manual: Each operation advances one step with the defined increment. Excite: Uses an external trigger signal via External I/O pin 15 (/Remote-Excite) to trigger.
Φ1 / Φ2 / Φ3		Opens the Step Mode setting page for the selected phase (Φ1 / Φ2 / Φ3).
APPLY ALL		Applies the selected phase's settings to all phases.
Count	1 ~ 99999, 0=Continuous	Step execution count: When the Count is set to 0, the system will loop through the step settings indefinitely until it reaches the system's maximum rated limit.
Dwell Time	0.1 ~ 99999999.9 ms	Duration of each step.
Start Deg	0.0 ~ 359.9 deg	Starting phase angle for each step.

Waveform	Refer to Section 4.6	Waveform selection.
Vac	0.0 ~ 350.0 V	Initial AC voltage value for Step Mode output.
Vdc	-495.0 ~ 495.0 V	Initial DC voltage value for Step Mode output.
Freq	30.0 ~ 150.0 Hz	Initial frequency value for Step Mode output.
Δ Vac	0.0 ~ 350.0 V	AC voltage increment per step.
Δ Vdc	-495.0 ~ 495.0 V	DC voltage increment per step.
Δ Freq	30.0 ~ 150.0 Hz	Frequency increment per step.

5.4 Pulse Mode (Pulse)

Pulse Mode is designed to simulate instantaneous voltage variations, making it especially suitable for test scenarios that require rapid and short-term voltage switching. In this mode, users can define the pulse amplitude, duration, and cycle count to generate specific voltage waveforms and accurately simulate how the Device Under Test (DUT) responds to different pulse waveforms. This function is particularly useful for evaluating a DUT's tolerance or response to short-term voltage disturbances, such as sudden load fluctuations or momentary voltage dips.

Pulse Mode allows users to programmatically overlay special waveforms on top of the settings in Base Mode. This mode supports configuring the pulse duration ratio and cycle length. From the Advanced Mode Setting (Mode Setting) page, press **BASE MODE** to open the dropdown menu and select "PULSE MODE" to enter Pulse Mode, as shown in Figure 5-19.

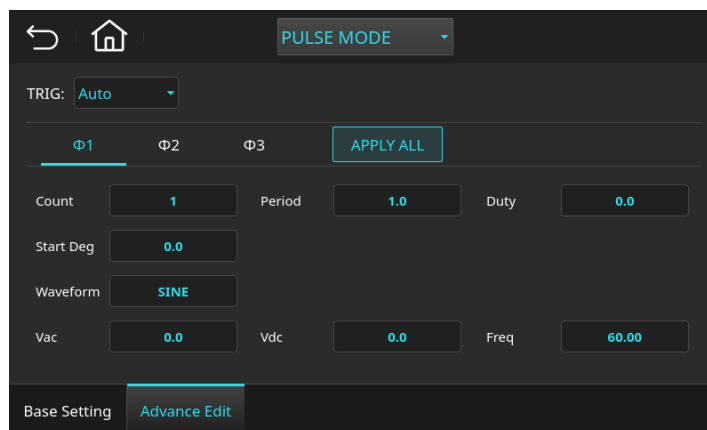





Figure 5-19 Pulse Mode Setting Page

■ TRIG = Auto: Press TRIG. ON to execute Pulse Mode (Pulse)

After setting the parameters, tap the Home key  to exit the Pulse Mode (Pulse) editing page. At this point, press  to trigger the output. The output status will be displayed in green text **PULSE MODE**, indicating that the regenerative power system is currently executing Pulse Mode (Pulse) output (see Figure 5-20). To stop Pulse Mode output, the user can press . Once the system completes the specified number of cycles, the main screen will display **PULSE MODE**, indicating the OUTPUT OFF status—i.e., no output is active (see Figure 5-21).

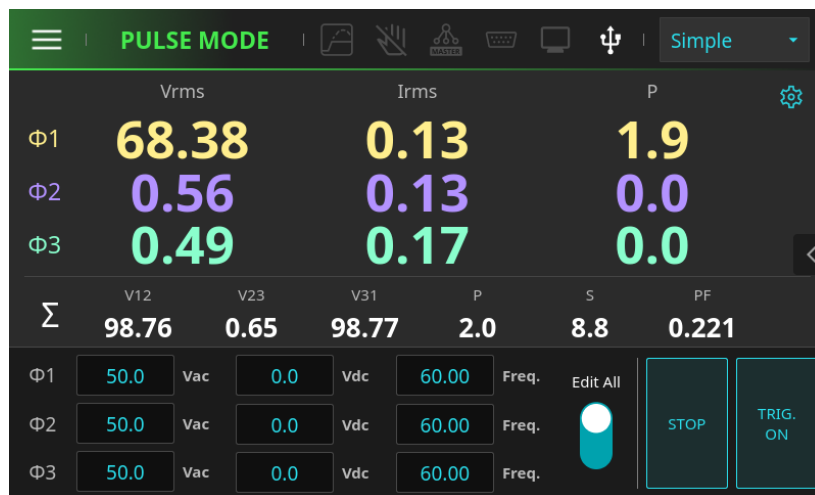

Figure 5-20 Three-Phase Mode Main Screen (Pulse Mode Output Status)

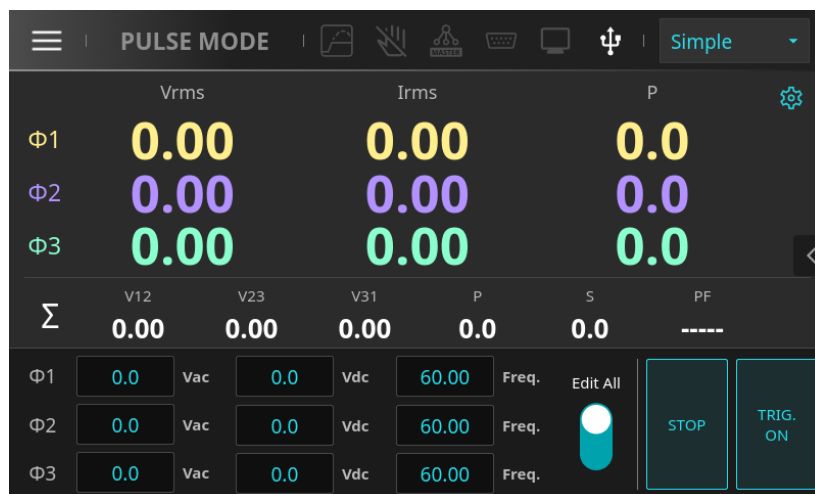

Figure 5-21 Three-Phase Mode Main Screen (Pulse Mode Standby Status)

■ Execute Pulse Mode (Pulse) During Output Operation by Pressing TRIG. ON

When the regenerative power system is in operation, pressing the OUTPUT OFF key will reduce the output voltage to 0V and immediately stop the output. If OUTPUT ON is pressed again, the system will only output the basic parameter settings shown on the main screen (i.e., Base Mode). To restart Pulse Mode, the user needs to press **TRIG. ON** to trigger it. This allows users to enable Pulse Mode at any time during OUTPUT ON, making operation more convenient.

Example: Configuring Phase 1 in Pulse Mode (Pulse) by the user is described as follows:

1. On the Pulse Mode (Pulse) page, tap the icon at the bottom **Base Setting**.
2. Tap the numeric input field for $\Phi 1$ on the screen **0.0**.
3. Enter **5**, **0**, then press **Enter** to change the value to "50.00".
4. On the Pulse Mode (Pulse) page, tap the icon at the bottom **Advance Edit**, then select **$\Phi 1$** .
5. Set TRIG = Auto and edit the parameters as shown in Figure 5-22.
6. After setting the parameters, tap the Home key **Home**, press the OUTPUT ON key, and then tap **TRIG. ON** to trigger the output. The output waveform is shown in Figure 5-23.

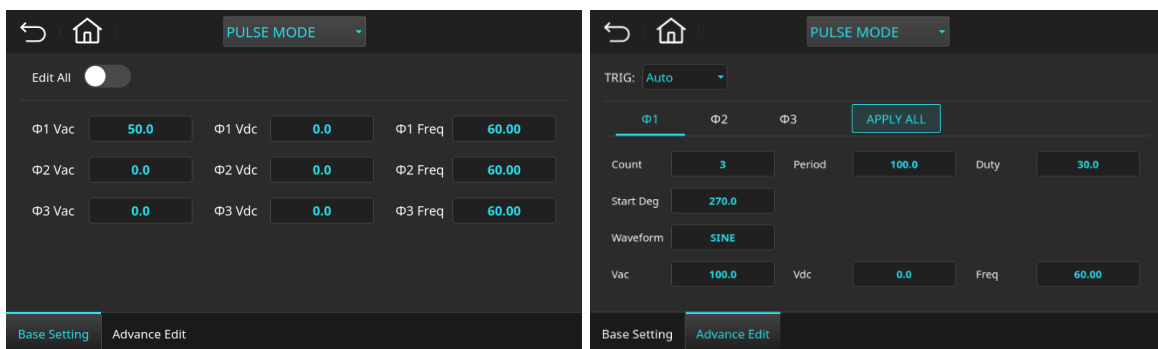

Figure 5-22 Pulse Mode Setting Page (Example Parameters for Phase 1)

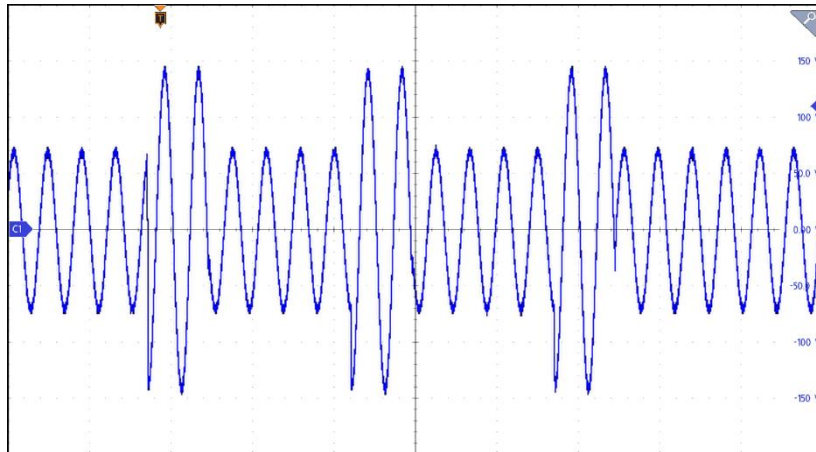

Figure 5-23 Pulse Mode Setting Page (Example Output Waveform for Phase 1)

Pulse Mode – Parameter Description:

Parameter	Sub-item	Description
TRIG	<ul style="list-style-type: none"> ■ Auto ■ Manual ■ Excite 	<p>Auto: Automatically executes all pulses according to the set Count.</p> <p>Manual: Executes the pulse waveform once; equivalent to Count = 1.</p> <p>Excite: Uses an external trigger signal via External I/O pin 15 (/Remote-Excite) to trigger the pulse.</p>
$\Phi 1 / \Phi 2 / \Phi 3$		Opens the Pulse Mode setting page for the selected phase ($\Phi 1 / \Phi 2 / \Phi 3$).
APPLY ALL		Applies the selected phase's parameter settings to all phases.
Count	1 ~ 99999, 0=Continuous	Number of pulse executions. When set to 0, the pulse waveform will loop continuously.
Period	0.1 ~ 99999999.9 ms	Total period length of one pulse cycle.
Duty	0.0 ~ 100.0 %	Duty cycle – the percentage of time the pulse is ON within one period.
Start Deg	0.0 ~ 359.9 deg	Output phase angle for each pulse waveform.
Waveform	Refer to Section 4.6	Waveform selection.
Vac	0.0 ~ 350.0 V	AC voltage output value in Pulse Mode.
Vdc	-495.0 ~ 495.0 V	DC voltage output value in Pulse Mode.
Freq	30.0 ~ 150.0 Hz	Frequency output value in Pulse Mode.

5.5 Synthesis Mode (Synthesis)

Synthesis Mode provides a flexible custom waveform design feature. Users can utilize an intuitive programming interface to precisely adjust the amplitude and phase of each harmonic order, generating composite waveforms composed of multiple harmonics. This mode supports up to 50 harmonic orders, helping testers simulate non-sinusoidal power environments to meet various testing requirements. This feature is especially suitable for testing the DUT's endurance and performance under complex harmonic waveforms. It is commonly used in harmonic distortion tests and power quality evaluations, assessing a device's adaptability and stability under real grid conditions. From the Advanced Mode Setting (Mode Setting) page, press

BASE MODE to open the dropdown menu and select "SYNTHESIS" to enter Synthesis Mode, as shown in

Figure 5-24.

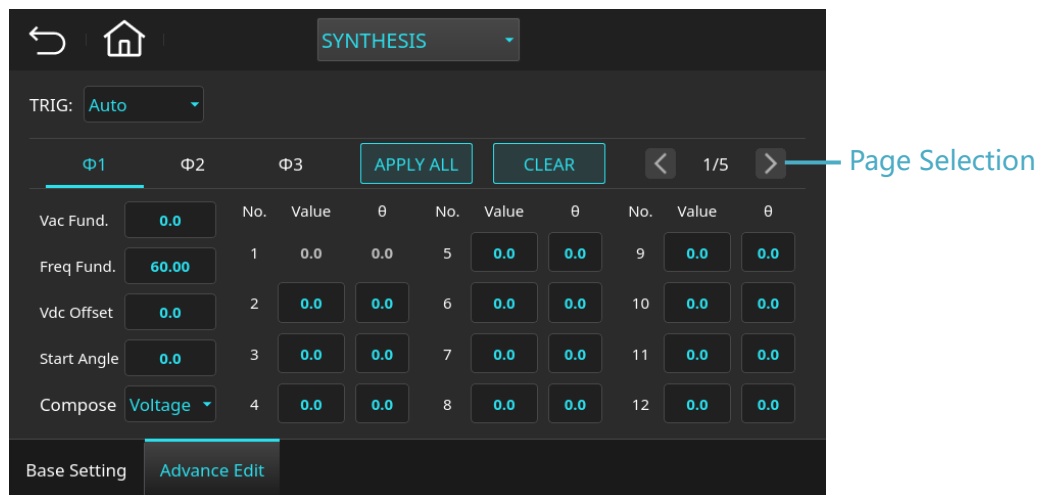

Figure 5-24 Synthesis Mode Setting Page



In the "Compose" settings of Synthesis Mode, "Voltage" and "Percent" refer to the adjustment methods for each harmonic component:

- A. **Voltage:** When this option is selected, the output amplitude of each harmonic can be directly set in voltage units (volts), allowing users to assign precise voltage values to specific harmonics. This setting is ideal for tests that require strict control over the voltage level of each harmonic order.

- B. **Percent**: This option sets each harmonic's amplitude as a percentage of the fundamental voltage. For example, if the fundamental frequency (e.g., 50Hz or 60Hz) voltage is 100V, setting a harmonic component to 10% means the harmonic's voltage is 10V. This relative value approach makes it easier to maintain consistent harmonic ratios when the base voltage changes.

The choice between the two depends on the testing requirements. For instance, when simulating voltage fluctuations or power quality scenarios, the Percent mode offers more flexibility. In contrast, for precise voltage control, the Voltage mode is more suitable.

■ TRIG = Auto: Press TRIG. ON to execute Synthesis Mode (Synthesis)

After setting the parameters, tap the Home key  to exit the Synthesis Mode editing page. At this point, press  to trigger the output. The output status will be displayed in green text **SYNTHESIS**, indicating that the regenerative power system is currently executing Synthesis Mode output (see Figure 5-25). To stop Synthesis Mode output, the user can press . The main screen will then display **SYNTHESIS**, indicating the OUTPUT OFF status—i.e., no output is active (see Figure 5-26).

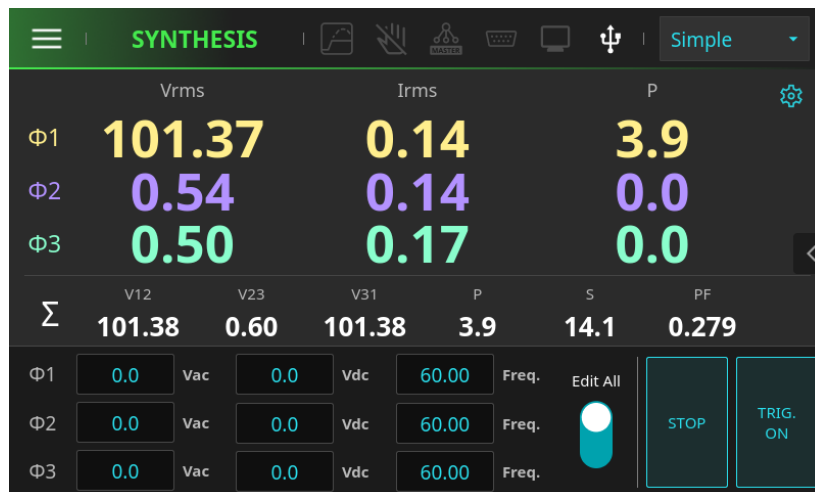

Figure 5-25 Three-Phase Mode Main Screen (Synthesis Mode Output Status)

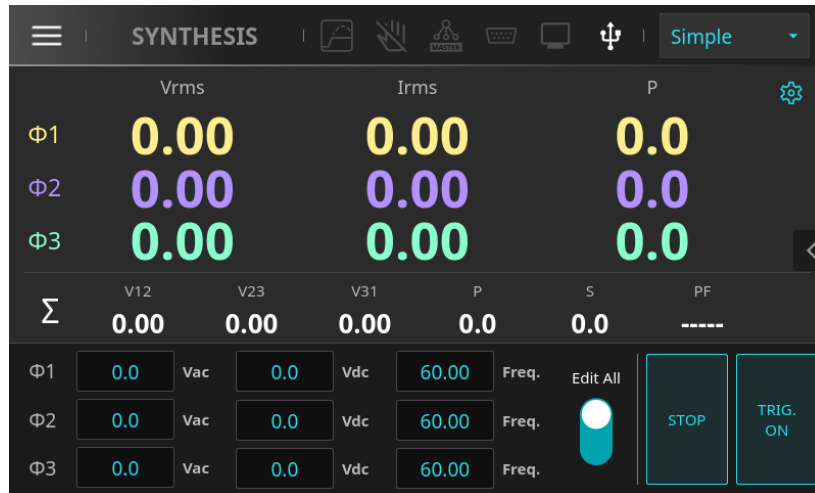

Figure 5-26 Three-Phase Mode Main Screen (Synthesis Mode Standby Status)

■ **During output operation, press TRIG. ON to execute Synthesis Mode (Synthesis)**

When the regenerative power system is in operation, pressing the OUTPUT OFF key will bring the output voltage down to 0V and immediately stop the output. If OUTPUT ON is pressed again, the system will only output the basic parameters shown on the main screen (i.e., Base Mode). To restart Synthesis Mode, the user needs to press **TRIG. ON** to trigger it. This allows users to activate the Synthesis Mode function at any time while in the OUTPUT ON state, making operation more convenient.

An example of configuring Phase 1 in Synthesis Mode (Synthesis) by the user is described as follows.

1. On the Synthesis Mode (Synthesis) page, select **Φ1**, then set TRIG = Auto.
2. Tap the Compose dropdown menu **Voltage** on the screen and select "Percent". Edit the parameters as shown in Figure 5-27.
3. After setting the parameters, tap the Home key **Home**, then tap **TRIG. ON** to trigger the output. The output waveform is shown in Figure 5-28.

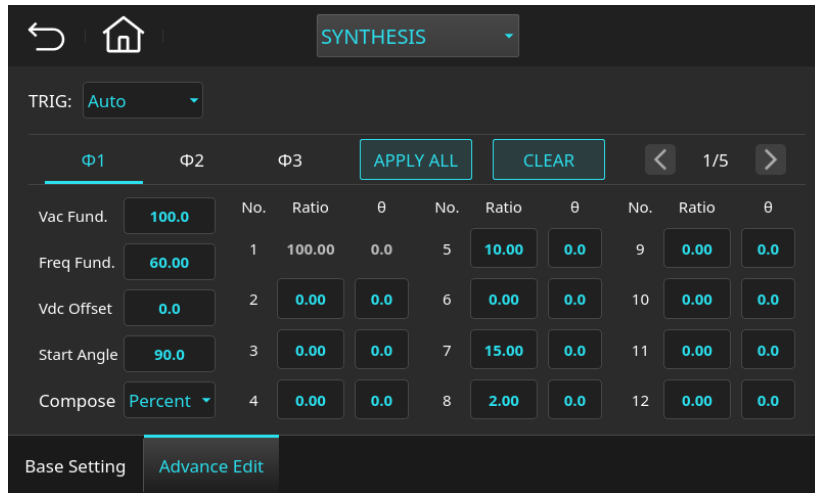

Figure 5-27 Synthesis Mode Setting Page (Example Parameters for Phase 1)

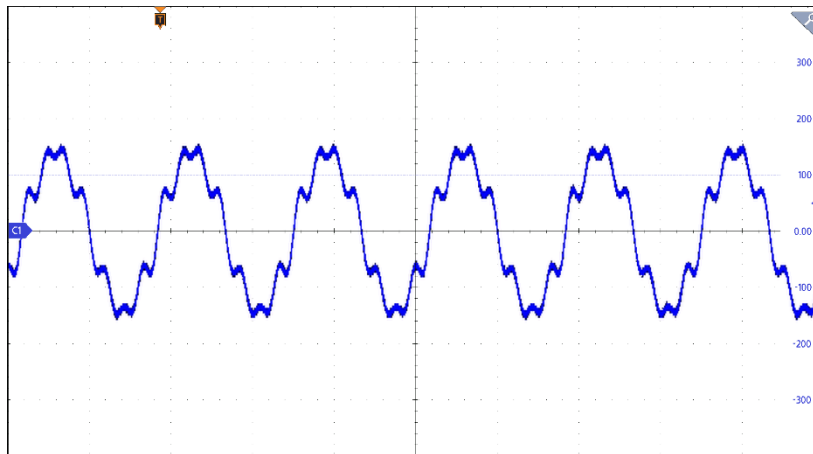

Figure 5-28 Synthesis Mode Setting Page (Example Output Waveform for Phase 1)

Synthesis Mode – Parameter Description:

Parameter	Sub-item	Description
TRIG	<ul style="list-style-type: none"> ■ Auto ■ Excite 	Auto: Automatically executes the configured synthesis waveform when triggered. Excite: Triggered via an external signal using External I/O pin 15 (/Remote-Excite).
Φ1 / Φ2 / Φ3		Opens the Synthesis Mode setting page for the selected phase (Φ1 / Φ2 / Φ3).
APPLY ALL		Applies the selected phase's parameter settings to all phases.
CLEAR		Clears the selected phase's parameter settings.
Vac Fund.	0.0 ~ 350.0 V	Fundamental AC voltage setting.
Freq Fund.	30.0 ~ 150.0 Hz	Fundamental frequency setting.
Vdc Offset	-495.0 ~ 495.0 V	DC voltage component in the output.
Start Angle	0.0 ~ 359.9 deg	Starting phase angle of the output waveform.

Compose	<ul style="list-style-type: none"> ■ Voltage ■ Percent 	Harmonic composition mode.
Value	0.0 ~ 350.0 V	Amplitude of each harmonic when Compose = Voltage.
Ratio	0.0 ~ 100.0 %	Amplitude as a percentage of the fundamental voltage when Compose = Percent.
θ	0.0 ~ 359.9 deg	Phase angle of each harmonic order.

WARNING

- The system imposes limits on the values of synthesized waveforms and the percentage of each harmonic component. To protect the equipment, when the user-configured harmonic content exceeds the allowable range, the system will automatically trigger the Overvoltage Protection (SET_OVP) function. This protection mechanism prevents the output of excessive harmonic levels, ensuring safe operation and avoiding damage to the DUT or the system itself.
- If the synthesized waveform includes high-frequency components that exceed the system's voltage limits, it may trigger protection mechanisms such as OVP_PEAK or OVP_VR.
- Due to the limited bandwidth of the regenerative power system, when high-frequency components are included in the synthesized waveform, output waveform distortion may occur.

5.6 Interharmonic Mode (Interharmonic)

The Interharmonic waveform editing function of the regenerative power system allows users to superimpose a variable-frequency voltage component on top of the fundamental voltage output. Users can customize the frequency and amplitude of the inserted interharmonic signal, making it possible to effectively test a device's immunity and stability under interharmonic disturbances commonly encountered in real-world power grids. From the Advanced Mode Setting (Mode Setting) page, press  to open the dropdown menu and select "INTERHARMONIC" to enter Interharmonic Mode, as shown in Figure 5-29.

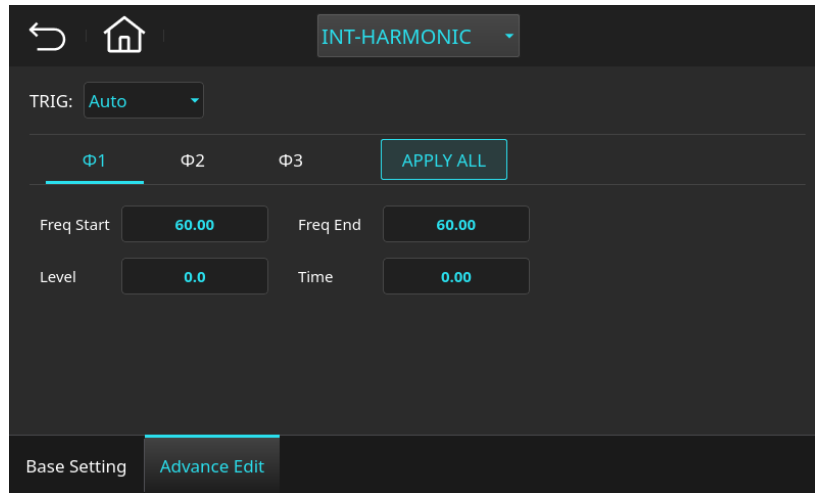







Figure 5-29 Interharmonic Mode Setting Page

■ **TRIG = Auto: Press TRIG. ON to execute Interharmonic Mode (Interharmonic)**

After setting the parameters, tap the Home key  to exit the Interharmonic Mode (Interharmonic) editing page. At this point, press  to trigger the output. The output status will be displayed in green text **INTERHARMONIC**, indicating that the regenerative power system is executing Interharmonic Mode output (see Figure 5-30).

After pressing the  key, the system will maintain the current interharmonic output waveform. Only when  is pressed again will the waveform proceed with the next interharmonic output. To stop the output, the user can press . When the system completes the output, the main screen will display **INTERHARMONIC**, indicating OUTPUT OFF status—i.e., no output is active (see Figure 5-31).

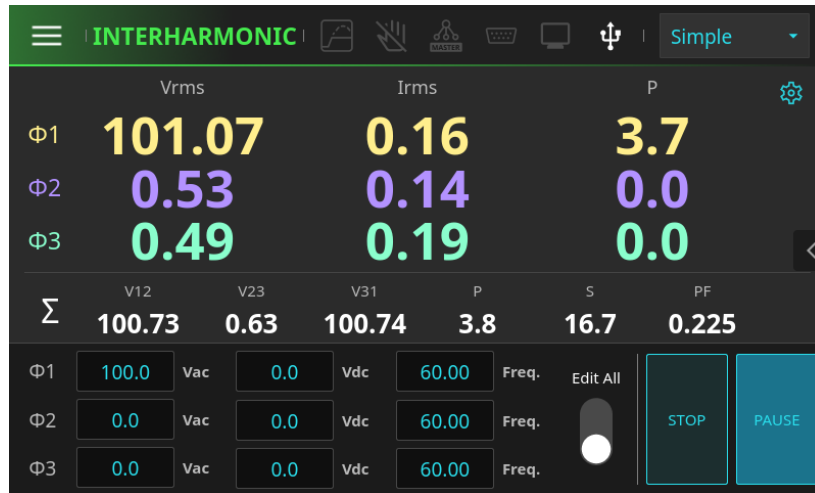

Figure 5-30 Three-Phase Mode Main Screen (Interharmonic Mode Output Status)

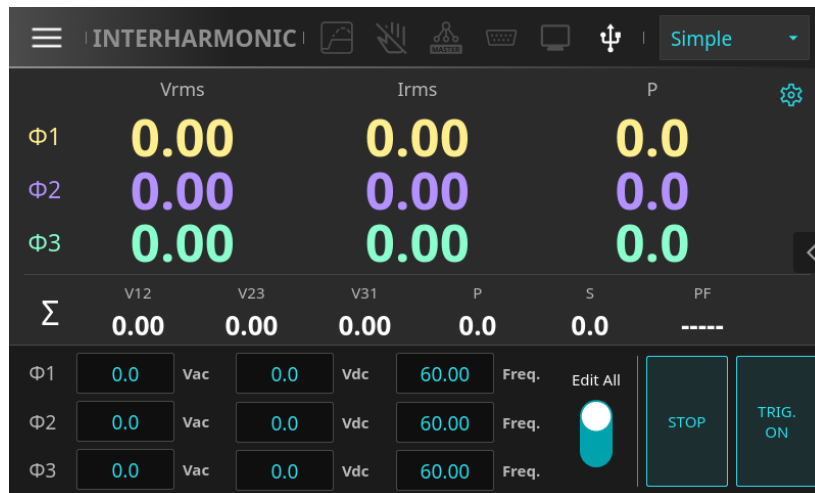









Figure 5-31 Three-Phase Mode Main Screen (Interharmonic Mode Standby Status)

- **During output operation, press TRIG. ON to execute Interharmonic Mode (Interharmonic).**

When the regenerative power system is in operation, pressing the OUTPUT OFF key will reduce the output voltage to 0V and immediately stop the output. If OUTPUT ON is pressed again, the system will only output the basic parameters shown on the main screen (i.e., Base Mode). To restart Interharmonic Mode, the user needs to press **TRIG. ON** to trigger it. This allows users to activate the Interharmonic Mode function at any time while in the OUTPUT ON state, making operation more convenient.

Example: Configuring Phase 1 in Interharmonic Mode (Interharmonic) by the user is described as follows:

1. On the Interharmonic Mode (Interharmonic) page, tap the icon at the bottom .
2. Tap the numeric input field for $\Phi 1$ on the screen .
3. Enter $\bar{1}$, $\bar{0}$, $\bar{0}$, then press  to change the value to "100.00".
4. On the Interharmonic Mode page, tap the icon at the bottom , then select .
5. Set TRIG = Auto, and edit the parameters as shown in Figure 5-32.
6. After setting the parameters, tap the Home key , then tap  to trigger the output. The output waveform is shown in Figure 5-33.

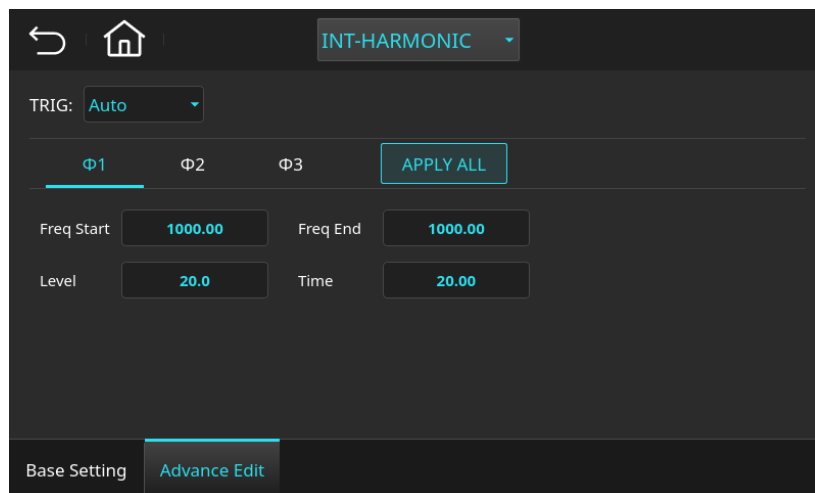

Figure 5-32 Interharmonic Mode Setting Page (Example Parameters for Phase 1)

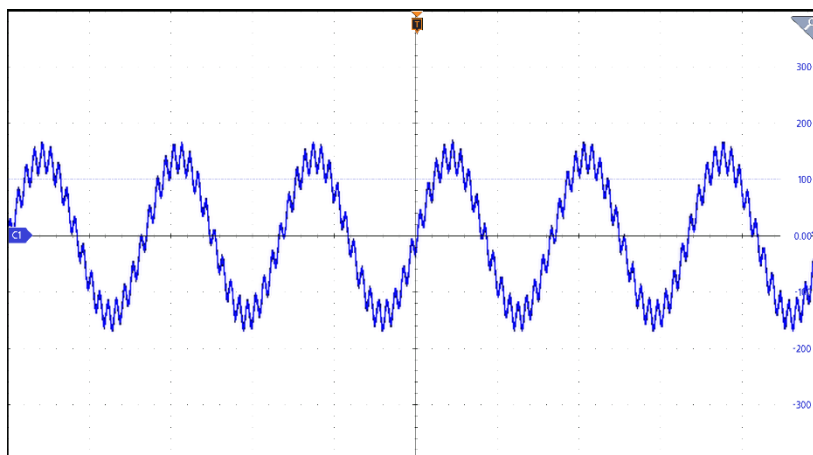

Figure 5-33 Interharmonic Mode Setting Page (Example Output Waveform for Phase 1)

Interharmonic Mode – Parameter Description:

Parameter	Sub-item	Description
TRIG	<ul style="list-style-type: none"> ■ Auto ■ Excite 	Auto: Automatically executes the configured interharmonic waveform upon triggering. Excite: Triggered via an external signal using External I/O pin 15 (/Remote-Excite).
Φ1 / Φ2 / Φ3		Opens the Interharmonic Mode setting page for the selected phase (Φ1 / Φ2 / Φ3).
APPLY ALL		Applies the selected phase's parameter settings to all phases.
Freq Start	0.01 ~ 3000.0 Hz	Sets the starting frequency of the interharmonic component.
Freq End	0.01 ~ 3000.0 Hz	Sets the ending frequency of the interharmonic component.
Level	0.0 ~ 100.0 %	Amplitude of the interharmonic component as a percentage of the AC voltage value set in Base Mode.
Time	0.00 ~ 99999.99 sec	Duration of the interharmonic waveform output.

NOTICE

- When entering Interharmonic Mode, the AC voltage waveform type in the Base Setting will automatically be set to Sine Wave and cannot be changed. This ensures the accuracy of the interharmonic superposition.

WARNING

- The system imposes limits on parameter values in Interharmonic Mode. To protect the equipment, if the user sets a harmonic amplitude that exceeds the allowable range, the system will automatically activate the Overvoltage Protection (SET_OVP) function. This protection mechanism prevents the output of excessively high harmonic components, ensuring safe operation and avoiding damage to the DUT or the system itself.
- If the interharmonic settings include high-frequency components that exceed the system's voltage limits, protection mechanisms such as OVP_PEAK or OVP_VR may be triggered.
- Due to the limited bandwidth of the regenerative power system, if high-frequency components are included in the waveform, output waveform distortion may occur.

5.7 Transient Waveform Mode (Transient)

Transient Waveform Mode (Transient Mode) provides surge and sag simulation functions, allowing users to superimpose short-term voltage changes on top of a stable output waveform to emulate sudden anomalies in power systems. This feature enables testing of a DUT's performance response and tolerance under rapid voltage fluctuations, such as voltage spikes or dips commonly encountered in power grids.

From the Advanced Mode Setting (Mode Setting) page, press **BASE MODE** to open the dropdown menu and select "TRANSIENT" to enter Transient Waveform Mode, as shown in Figure 5-34.

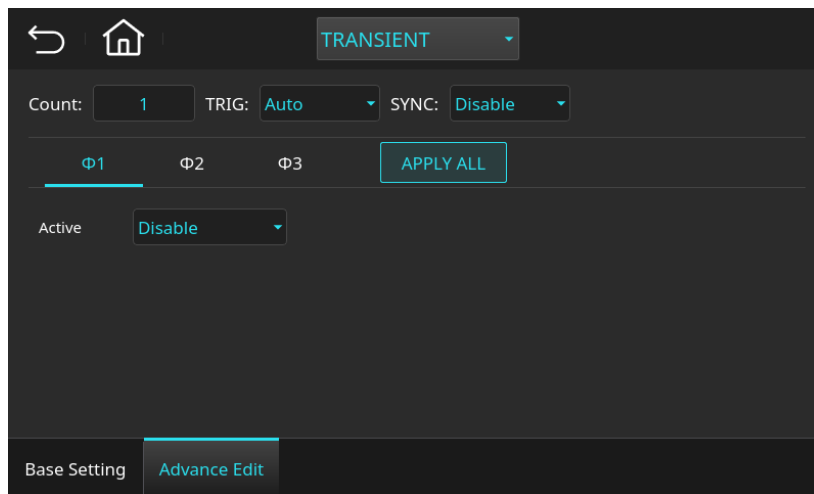



Figure 5-34 Transient Waveform Mode (Transient) Setting Page

■ TRIG = Auto: Press TRIG. ON to execute Transient Waveform Mode (Transient)

After setting the parameters, tap the Home key  to exit the Transient Mode editing page. At this point, press **TRIG. ON** to trigger the output. The output status will appear in green text **TRANSIENT**, indicating that the regenerative power system is executing Transient Mode output (see Figure 5-35). To stop the output of Transient Mode, the user can press **STOP**. Once the system completes the output, the main screen will display **TRANSIENT**, indicating the OUTPUT OFF status—i.e., no active output (see Figure 5-36).

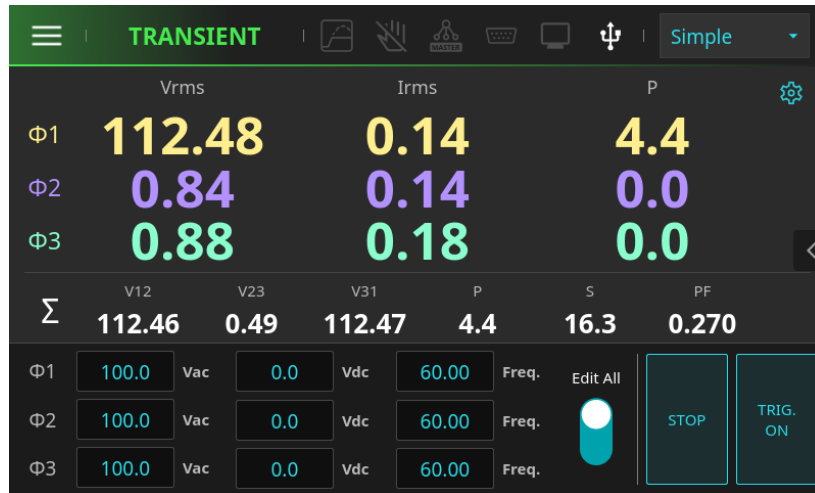

Figure 5-35 Three-Phase Mode Main Screen (Transient Waveform Mode Output Status)

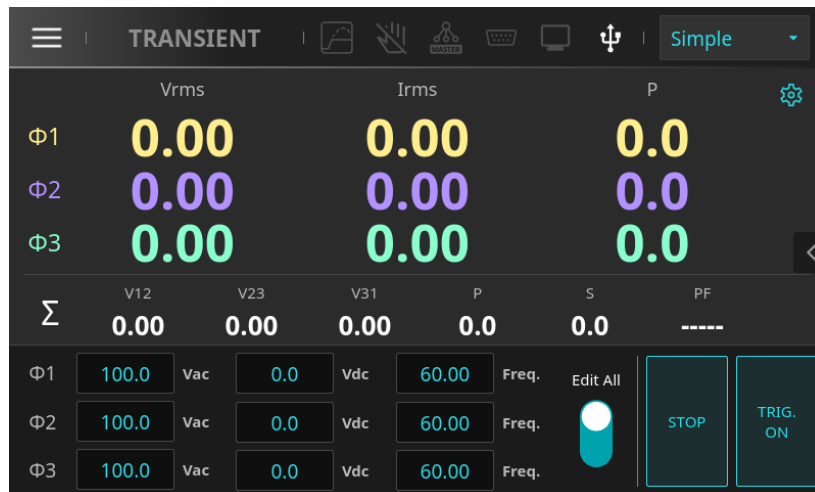









Figure 5-36 Three-Phase Mode Main Screen (Transient Waveform Mode Standby Status)

- During output operation, press TRIG. ON to execute Transient Waveform Mode (Transient)**

When the regenerative power system is in operation, pressing the OUTPUT OFF key will reduce the output voltage to 0V and immediately stop the output. If OUTPUT ON is pressed again, the system will only output the basic parameters shown on the main screen (i.e., Base Mode). To restart Transient Waveform Mode, the user must press  to trigger it. This allows users to enable the Transient Mode function at any time while the system is in OUTPUT ON state, providing a more convenient operation experience.

Example: Configuring Phase 1 in Transient Waveform Mode (Transient) by the user is described as follows:

1. On the Transient Waveform Mode (Transient) page, tap the icon at the bottom .
2. Tap the numeric input field for $\Phi 1$ on the screen .
3. Enter $\bar{1}$, $\bar{0}$, $\bar{0}$ then press  to change the value to "100.00".
4. On the Transient Mode page, tap the icon at the bottom , then select .
5. Set TRIG = Auto, and edit the parameters as shown in Figure 5-37.
6. After setting the parameters, tap the Home key , then tap  to trigger the output. The output waveform is shown in Figure 5-38.

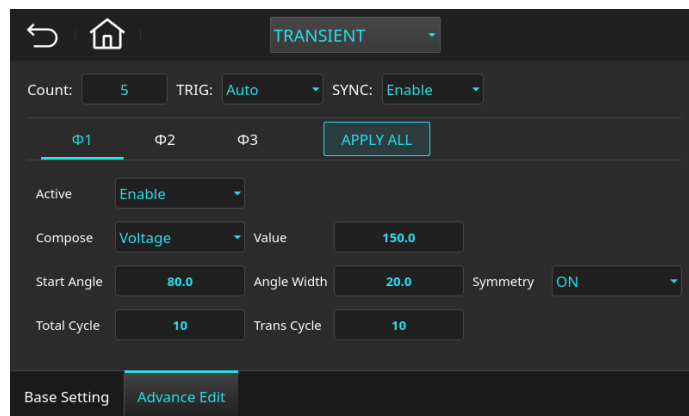

Figure 5-37 Transient Waveform Mode Setting Page (Example Parameters for Phase 1 – Surge)

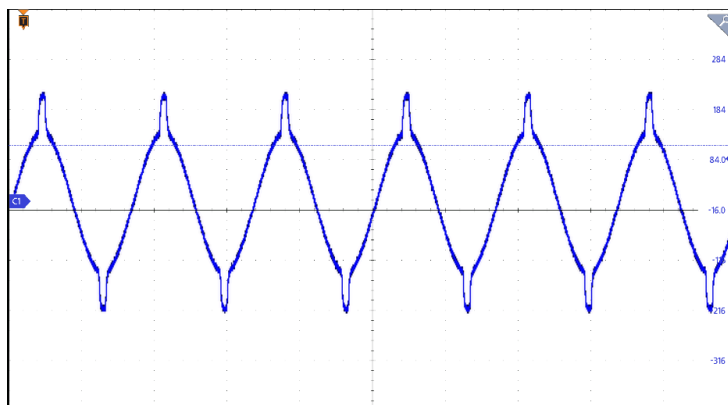



Figure 5-38 Transient Waveform Mode Setting Page (Example Output Waveform for Phase 1 – Surge)

7. Repeat steps 1 to 4 above, set TRIG = Auto, and edit the parameters as shown in Figure 5-39.

8. After setting the parameters, tap the Home key , then tap  to trigger the output. The output waveform is shown in Figure 5-40.

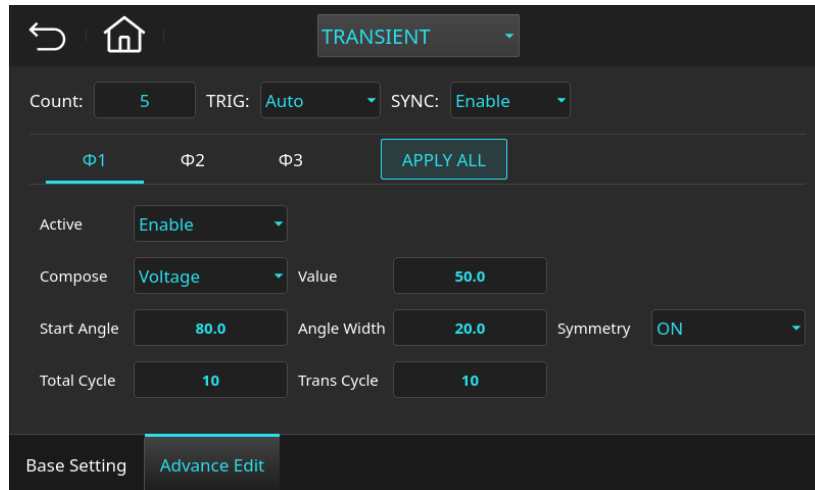

Figure 5-39 Transient Waveform Mode Setting Page (Example Parameters for Phase 1 – Sag)

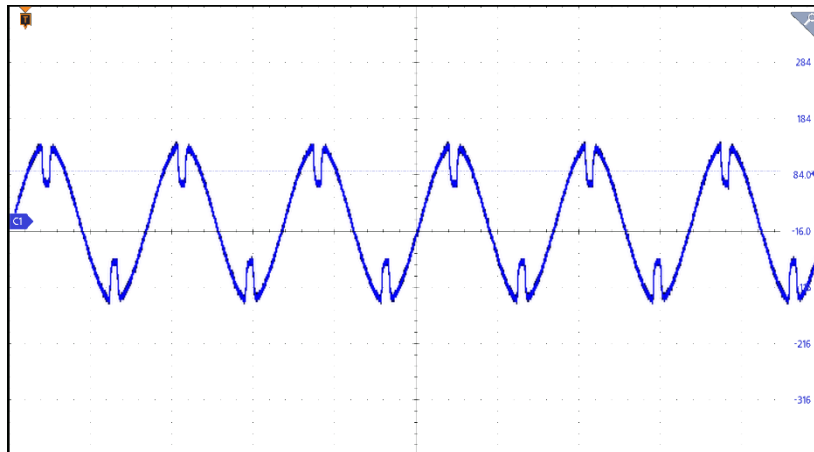

Figure 5-40 Transient Waveform Mode Setting Page (Example Output Waveform for Phase 1 – Sag)

Transient Waveform Mode – Parameter Description:

Parameter	Sub-item	Description
Count	1 ~ 99999, 0=Continuous	Number of transient waveform executions. When set to 0, the system will continuously loop the transient waveform configuration.
TRIG	<ul style="list-style-type: none"> ■ Auto ■ Manual ■ Excite 	Auto: Automatically executes all cycles according to the set Count. Manual: Executes the transient waveform once; same effect as Count = 1. Excite: Triggered via external signal using External I/O pin 15 (/Remote-Excite).
SYNC	<ul style="list-style-type: none"> ■ Enable ■ Disable 	Enable: Three-phase output is synchronized with Phase 1's set position; surges and sags occur at the specified angle. Disable: Each phase outputs surge/sag independently based on its own settings.
Φ1 / Φ2 / Φ3		Opens the Transient Waveform Mode setting page for the selected phase (Φ1 / Φ2 / Φ3).
APPLY ALL		Applies the selected phase's parameter settings to all phases.
Active	<ul style="list-style-type: none"> ■ Enable ■ Disable 	Enable: Enables transient waveform function. Disable: Disables transient waveform function.
Compose	<ul style="list-style-type: none"> ■ Voltage ■ Percent 	Method for defining transient waveform components.
Value	0.0 ~ 350.0 V	Amplitude of the transient waveform when Compose = Voltage.
Ratio	0.0 ~ 100.0 %	Voltage percentage of the transient waveform when Compose = Percent.
Direction	<ul style="list-style-type: none"> ■ Surge ■ Sag 	Surge: Simulates voltage rise. Sag: Simulates voltage dip.
Start Angle	0.0 ~ 359.9 deg	Angle at which surge or sag begins.
Angle Width	0.0 ~ 359.9 deg	Width of the surge or sag in degrees. Example: If Start Angle = 80 deg and Angle Width = 20 deg, the surge/sag occurs from 80° to 100°.
Symmetry	<ul style="list-style-type: none"> ■ ON ■ OFF 	Defines whether the surge/sag is symmetric in both positive and negative cycles.
Total Cycle	1 ~ 99999	Total number of test cycles for surge/sag.
Trans Cycle	0 ~ 99999	Number of cycles that include surge/sag events. Example: If Total Cycle = 10 and Trans Cycle = 5, surges/sags occur in 5 cycles, and the remaining 5 cycles are normal output.

NOTICE

- When Start Angle is set to a specific value, the allowable range for Angle Width is restricted and must not exceed half a cycle (180 degrees). For example, if Start Angle is set to 80 degrees, the maximum Angle Width can be 100 degrees; if Start Angle is set to 270 degrees, the maximum Angle Width can be 90 degrees. If the configured value exceeds this limit, the system will automatically constrain the output to the maximum allowed value.

6 System Function Description



From the main menu function page, press the **System** function key to enter the System Function Setting page (System), as shown in Figures 6-1 and 6-2. Multiple power system options can be configured here, including power mode switching (power supply mode, load mode), remote sensing and remote inhibit functions, external voltage reference input, output monitoring, automatic output on startup, parallel mode, basic parameter setting limits, system factory reset, remote communication interfaces, system calibration, and basic settings (such as screen brightness, buzzer volume, date/time, language selection, and screen lock function).

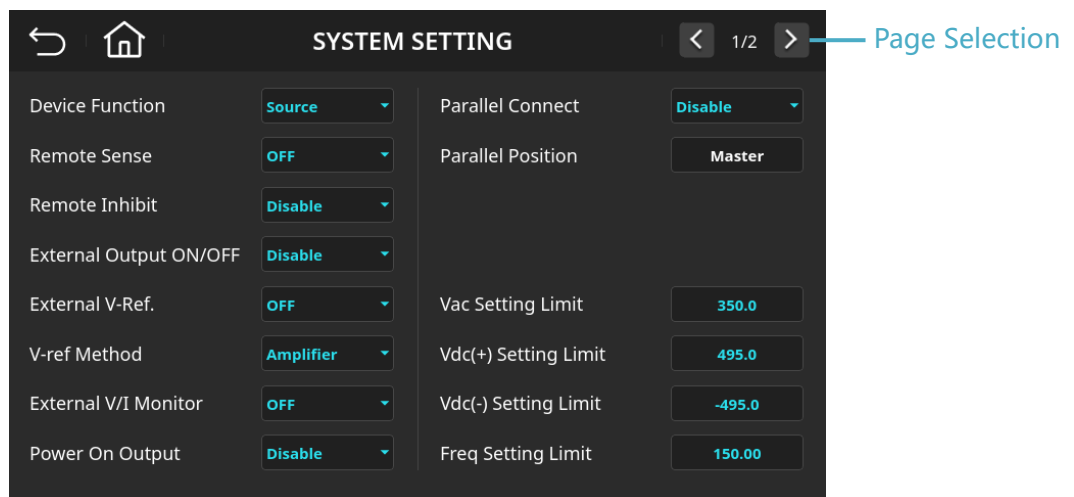

Figure 6-1 System Function Setting Page 1

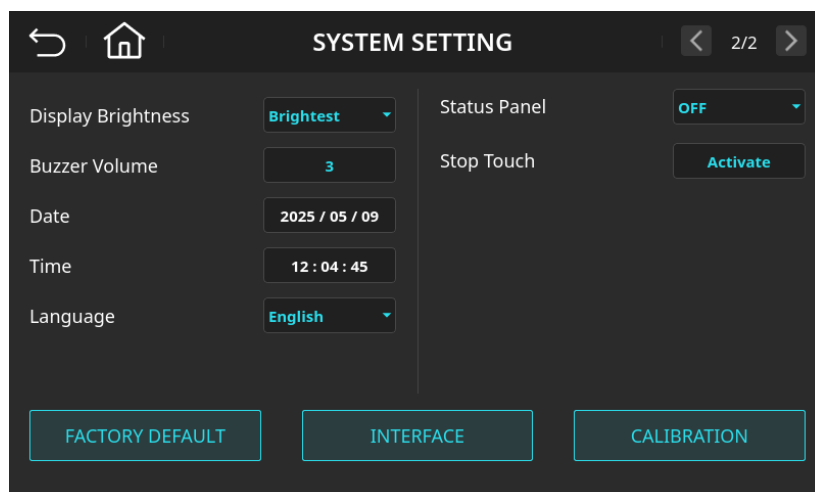
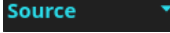



Figure 6-2 System Function Setting Page 2

6.1 Mode Switching (Device Function)

The regenerative power system includes a mode switching function, allowing users to toggle between Source Mode and Load Mode. In Source Mode, the simulator provides a stable voltage and current output to power external devices. In Load Mode, the system can absorb power, simulating how a device operates under different load conditions.

Example: Switching the regenerative power system to Load Mode

1. On the System Function Setting page, tap the Device Function icon  to open the dropdown menu.
2. Select "AC Load", then tap the Home key  to switch to Load Mode.

NOTICE

- For detailed specifications and information on the regenerative load function, please refer to Chapter 9 of this manual.
- Load Mode is an optional feature, available only for regenerative power systems with the appropriate license. Please ensure that the feature has been purchased and activated before using Load Mode for related testing.

6.2 Remote Sense Function

The Remote Sense function is used to compensate for voltage drops in the wiring between the power output and the load. When the load is located some distance away from the power supply, current flowing through the wires causes a voltage drop, resulting in the actual voltage at the load being lower than the set value. By enabling Remote Sense, the power supply can monitor the actual voltage at the load side and automatically adjust its output to compensate for the drop, ensuring that the load receives the correct voltage as configured.

Example: Enabling the Remote Sense function on the regenerative power system is described as follows.

1. On the System Function Setting page, tap the Remote Sense icon **OFF** to open the dropdown menu.
2. Select “ON” to enable the Remote Sense function, as shown in Figure 6-3.

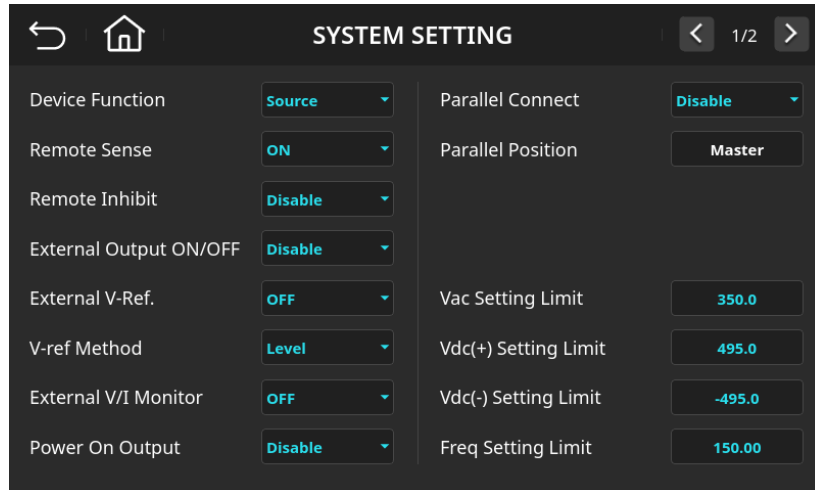

Figure 6-3 System Function Setting Page (Remote Sense = ON)

NOTICE

- For the Remote Sense output wiring method, please refer to Section 3.4.1 for detailed instructions.

6.3 Remote Output Control

The output of the regenerative power system can be inhibited either manually or via external control. Remote control signals for output and inhibition are received through the External I/O terminal on the rear panel (see Chapter 12 for pin definitions). These functions allow users to manage the system's operational state remotely, providing precise control over power delivery during testing—especially in scenarios where controlling the power switch or preventing unintentional voltage output is critical.

Remote Inhibit is a remote suppression function that allows users to control the AC power supply output status through an external signal. When a low-level signal (e.g., External I/O terminal input is Low) is received, the system stops voltage output. When the signal changes to high-level (High), the output remains in an inhibited state until the user manually or remotely restarts the output.

Example: Enabling the Remote Inhibit function on the regenerative power system is described as follows.

1. On the System Function Setting page, tap the Remote Inhibit icon **Disable** to open the dropdown menu.
2. Select "Enable" to activate the Remote Inhibit function, as shown in Figure 6-4.

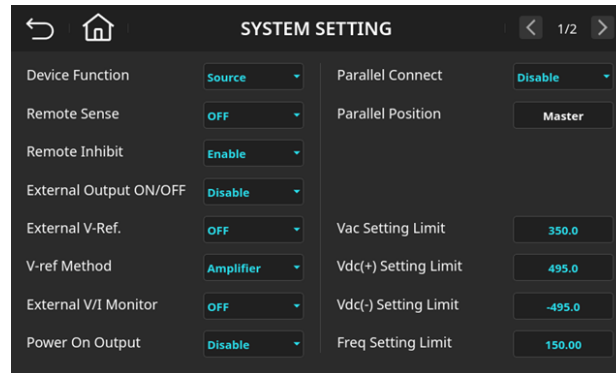

Figure 6-4 System Function Setting Page (Remote Inhibit = Enable)

External Output ON/OFF is a remote output control function that allows users to start or stop the power output via an external signal. When a high-level signal is received, the output is turned OFF (OUTPUT OFF); when the signal is low-level, the output is turned ON (OUTPUT ON).

Example: Enabling the External Output Control function on the regenerative power system is described as follows.

1. On the System Function Setting page, tap the External Output ON/OFF icon **Disable** to open the dropdown menu.
2. Select "Enable" to activate the remote output control function, as shown in Figure 6-5.

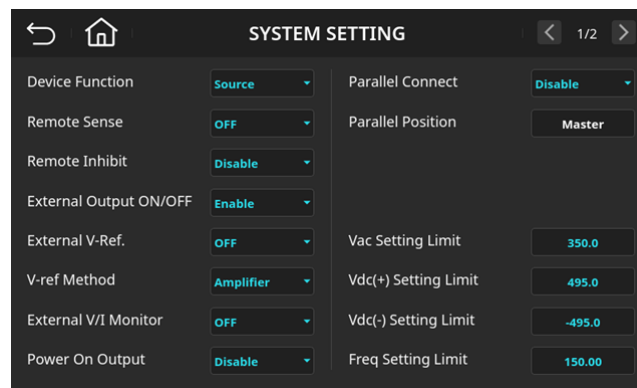

Figure 6-5 System Function Setting Page (External Output ON/OFF = Enable)

6.4 External Voltage Reference Input Function (External V-Ref.)

The External V-Ref. function allows users to adjust the output voltage of the regenerative power system using an analog signal from an external device. This feature provides an input interface through the External I/O terminal on the rear panel, enabling users to select a control method according to their needs. Users can configure control parameters via the V-ref. Method setting, and the system offers two coupling modes: Amplifier Mode and Level Mode, to accommodate different signal processing requirements. By using an external voltage reference source, the system can interoperate with other measurement devices or testing environments, making this function particularly useful in applications where output parameters need to be adjusted based on external conditions or device behavior. It offers a more flexible control approach.

Amplifier : The output voltage (V_o) is a combination of the main screen's voltage setting and the amplified input from the external voltage reference source. The input range of the external voltage reference source is -10 V to 10 V. When the main screen values $V_{ac} = 0$ and $V_{dc} = 0$, the output voltage (V_o) can be calculated as follows:

$$\text{DC Voltage Calculation: } V_o(\text{dc}) = \frac{V_{\text{ref}}(\text{dc})}{10(\text{dc})} \times 495V_{\text{dc}}(\text{System Rated Upper Limit Value})$$

$$\text{AC Voltage Calculation: } V_o(\text{ac}) = \frac{V_{\text{ref}}(\text{ac})}{7.072(\text{ac})} \times 350V_{\text{ac}}(\text{System Rated Upper Limit Value})$$

Level: The output voltage $V_o(\text{ac})$ or $V_o(\text{dc})$ varies in linear proportion to the external DC voltage reference source. The input range is from -10 V to 10 V. The output voltage (V_o) is calculated as follows:

$$\text{DC Voltage Calculation: } V_o(\text{dc}) = \frac{V_{\text{ref}}(\text{dc})}{10(\text{dc})} \times 495V_{\text{dc}}(\text{System Rated Upper Limit Value})$$

$$\text{AC Voltage Calculation: } V_o(\text{ac}) = \frac{|V_{\text{ref}}(\text{dc})|}{10(\text{dc})} \times 350V_{\text{ac}}(\text{System Rated Upper Limit Value})$$

A design example where the user uses a coupling method to set the amplifier's Phase 1 output voltage (V_o) to 200Vdc is described as follows:

1. On the system function settings page, click the icon for External V-Ref.  to open the drop-down menu.

2. After selecting "ON", click the icon for V-ref. Method **Amplifier** to open its drop-down menu.
3. After selecting "Amplifier", as shown in Figure 6-6, click the Home button .
4. External reference voltage calculation method: $V_{ref}(dc) = \frac{200 \times 10}{495} = 4.04V_{dc}$
5. Inject the external reference voltage of 4.04Vdc into terminal pins 6 (Ext-V Φ1) and 17 (AGND) on the External I/O interface.
6. After setting Vac = 0 and Vdc = 0 in the basic parameter settings on the main screen, press OUTPUT ON and the output voltage (Vo) will be 200Vdc.

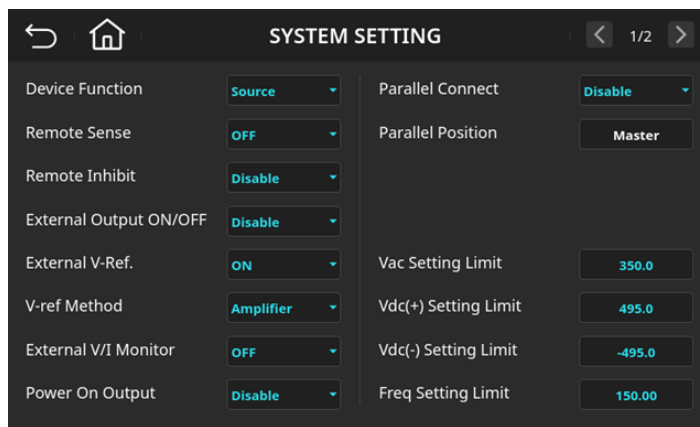

Figure 6-6 System Function Settings Page (External V-Ref.=ON, V-ref Method=Amplifier)

NOTICE

- For details on the functions of the External I/O terminal pins, please refer to Chapter 11.

6.5 Output Voltage/Current Monitoring Function (External V/I Monitor)

The regenerative power system is equipped with an External Voltage/Current Monitoring function (External V/I Monitor), which outputs real-time voltage and current signals as analog voltages proportional to the actual output. This allows external devices to monitor the output in real time. The function supports connection to oscilloscopes, data acquisition systems (DAQ), or upper-level control platforms, enabling real-time monitoring, data logging, and system integration—particularly suitable for automated test environments. The monitoring

signals are output via the External I/O terminals on the rear panel of the device, facilitating hardware connections and signal integration while ensuring high reliability in real-time monitoring.

The monitoring voltage signal (VMON) output through the External I/O terminal corresponds proportionally to the phase output voltage (VΦ1 / VΦ2 / VΦ3) shown on the main screen, and is provided in the form of an analog voltage. The output range of the external voltage monitoring signal is –10 V to +10 V, enabling real-time monitoring of output phase voltage. When both Vac = 0 and Vdc = 0 are displayed on the main screen, the VMON signal output from the External I/O terminal can be calculated using the following formula to confirm the actual output relationship:

$$\text{DC Voltage Calculation Method: } Vo(dc) = \frac{VMON(dc)}{10(dc)} \times 819.2Vdc(\text{system rated maximum})$$



$$\text{AC Voltage Calculation Method: } Vo(ac) = \frac{VMON(ac)}{7.072(ac)} \times 579.26Vac(\text{system rated maximum})$$

The current monitoring signal (IMON) output via the External I/O terminal corresponds proportionally to the output current (IΦ1 / IΦ2 / IΦ3) displayed on the main screen and is output as an analog voltage. The output range of the external current monitoring signal is –10 V to +10 V, providing real-time output current monitoring capability. When both Iac = 0 and Idc = 0 are shown on the main screen, the IMON voltage output from the External I/O terminal can be calculated using the following formula to verify the actual output relationship:

$$\text{DC Current Calculation: } Io(dc) = \frac{IMON(dc)}{10(dc)} \times 409.6Idc(\text{system rated maximum})$$

$$\text{AC Current Calculation: } Io(ac) = \frac{IMON(ac)}{7.072(ac)} \times 289.6Iac(\text{system rated maximum})$$

A design example for users to monitor a 100 Vdc output voltage on Phase 1 via the External I/O terminal is described below:

1. On the system function settings page, tap the External V/I Monitor icon  to open the dropdown menu.
2. Select "ON", then, as shown in Figure 6-7, tap the Home icon  to return to the main screen.

- On the main screen, tap the Vdc input field **0.0** for $\Phi 1$
- Enter 1, 0, 0, then press the Enter key **Enter**; the value will change to "100.00"
- Press the OUTPUT ON button, then measure between pin 2 (VMON $\Phi 1$) and pin 15 (AGND) on the External I/O terminal.
- External voltage monitoring signal calculation: $VMON(dc) = \frac{100}{819.2} \times 10 = 1.22Vdc$

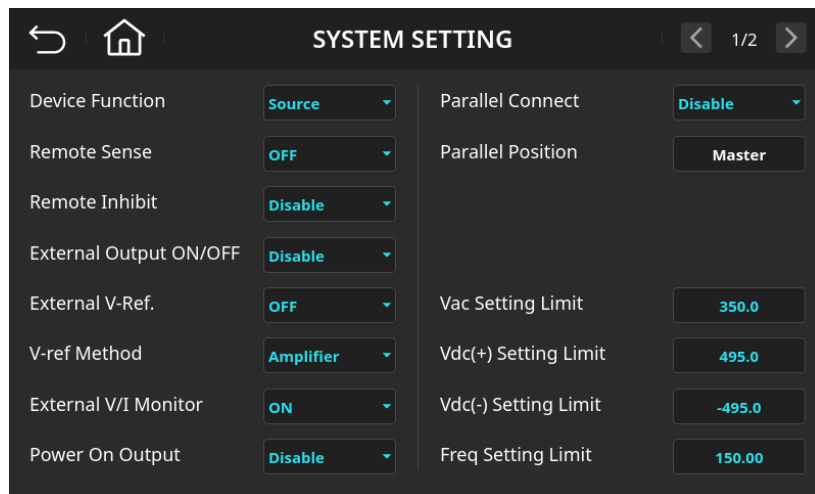

Figure 6-7 System Function Settings Page (External V/I Monitor = ON)

6.6 Output State Setting (Power On Output)

The regenerative power system includes a built-in Power On Output setting feature. Users can access it by

selecting the function key **System** from the main menu to enter the System Settings page, and configure the Power On Output field to define the output behavior when the system is powered on.

By default, this feature is set to Disable, meaning the device will not automatically output voltage upon startup — the user must manually enable output to ensure operational safety. When set to Enable, the system will display a safety prompt (as shown in Figure 6-8) to inform the user that enabling this function will store the current output

parameters displayed on the main screen (such as voltage, frequency, etc.), and will automatically apply these default values during the next startup, as shown in Figure 6-9.

This feature is particularly useful for unattended environments or automated test applications, ensuring the device resumes its predefined output conditions after power is restored. However, it is strongly recommended to perform a thorough safety assessment before enabling this function to avoid potential risks from preset outputs.

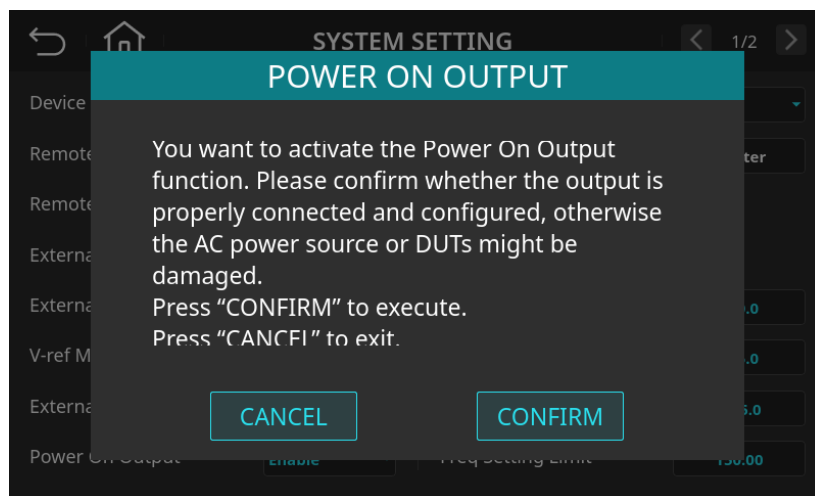

Figure 6-8 Output State Setting Safety Prompt Page

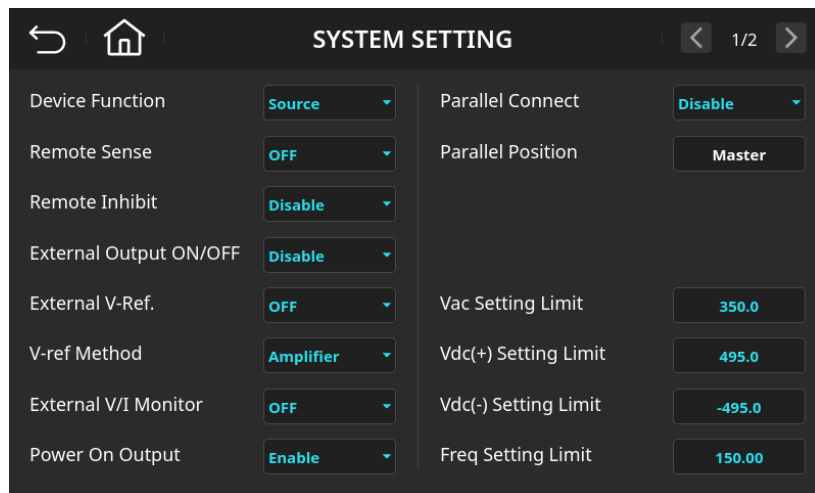



Figure 6-9 System Function Settings Page (Power On Output = Enable)

6.7 Parallel Connection Setting (Parallel Connect)

The regenerative power system supports parallel operation, allowing multiple units to be connected in parallel to increase total output capacity and meet high-power load requirements. In parallel mode, each unit outputs power synchronously, and the built-in master-slave control mechanism ensures uniform voltage and current distribution, enhancing system stability and reliability.

Users can enable parallel mode from the system settings menu. Before activation, the parallel communication cables on the rear panels must be properly connected. The system will automatically detect the connection status, and the first device with the parallel function enabled will be designated as the Master, while the remaining units will automatically become Slaves. The Master unit manages unified control and parameter delivery, while the Slaves follow and synchronize their output accordingly, ensuring coordinated system operation.

A design example for setting up two units in parallel is described as follows:

1. Connect the parallel communication cables on the rear panels of the two units.
2. On the System Function Settings page, tap the Parallel Connect icon  to open the dropdown menu.
3. Select "Enable", then, as shown in Figure 6-10, tap the Home button  to return to the main screen.
4. After enabling the parallel function, the system will automatically designate the unit with the function enabled as the Master, and the remaining unit(s) will be automatically configured as Slaves, with the "Slave" label displayed on their interfaces for easy identification.

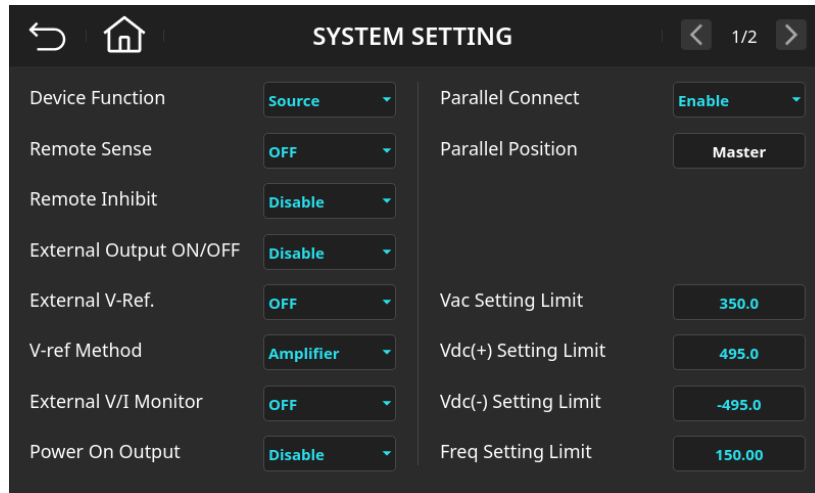

Figure 6-10 System Function Settings Page (Parallel Connect = Enable)

6.8 Output Setting Limits (Setting Limit)

The regenerative power system includes a built-in Setting Limit function, designed to prevent users from configuring output parameters that exceed the system's specifications, thereby ensuring operational safety and device stability. When users set output voltage, current, frequency, or other parameters via the main screen or remote interface, the system will immediately compare the entered values against internally predefined maximum and minimum allowable limits. If the input exceeds these limits, an error message such as "Setup Limit Exceeded" will be displayed on the screen (as shown in Figure 6-11), and the system will reject the setting to avoid abnormal behavior or potential equipment damage caused by improper configuration.

This setting limit function operates at the software level for user protection, rather than as a hardware-level safeguard. While it effectively prevents incorrect parameter entry, users should still conduct a comprehensive safety evaluation and consider the specific application requirements during actual operation.

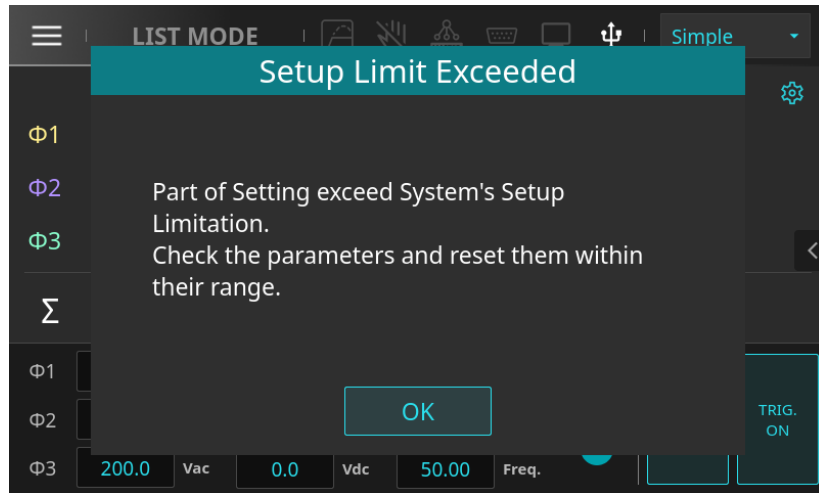

Figure 6-11 Setup Limit Exceeded Warning Message Page

NOTICE

- This function is applicable only to basic parameter settings on the main screen and covers all output modes (such as single-phase, split-phase, and three-phase), ensuring a consistent protection mechanism across different operating modes.

6.8.1 AC Output Voltage Setting Limit (Vac Setting Limit)

The AC Output Voltage Setting Limit (Vac Setting Limit) applies to the basic mode on the main screen and restricts the maximum configurable AC output voltage (Vac) to ensure safe operation.

The following steps describe how to set Vac Setting Limit = 200:

1. On the System Function Settings page, tap the numeric input field **350.0** for Vac Setting Limit.
2. Enter 2, 0, 0, then press the Enter key **Enter**; the value will update to "200.0", as shown in Figure 6-12.

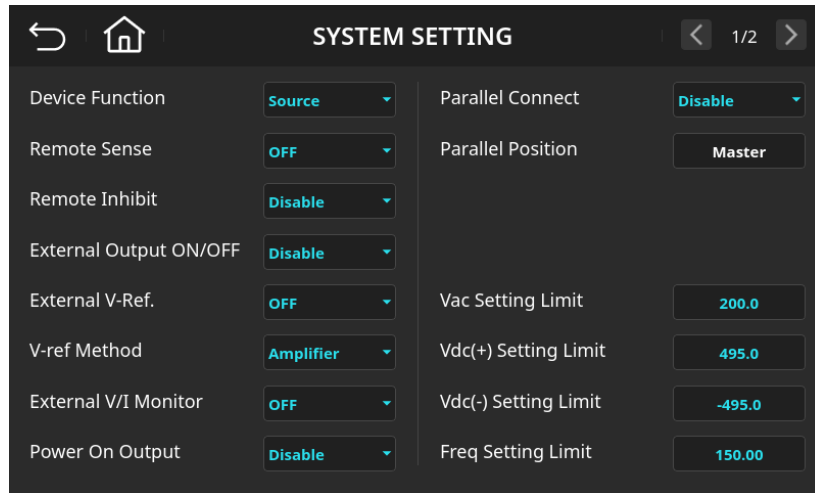

Figure 6-12 System Function Settings Page (Vac Setting Limit = 200.0)

6.8.2 DC Output Voltage Setting Limit (Vdc Setting Limit)

The Vdc Setting Limit applies to the basic mode on the main screen and is used to restrict the range of DC output voltage (Vdc). Vdc(+) limits the maximum positive DC voltage setting, while Vdc(-) limits the maximum negative voltage setting, preventing over-setting and ensuring operational safety. If the configured value exceeds the allowable range, the system will display a warning and block the action.

The following steps describe how to set Vdc(-) Setting Limit = 0:

1. On the System Function Settings page, tap the numeric input field **-495.0** for Vdc(-) Setting Limit.
2. Enter 0, then press the Enter key **Enter**; the value will update to "0.0", as shown in Figure 6-13.

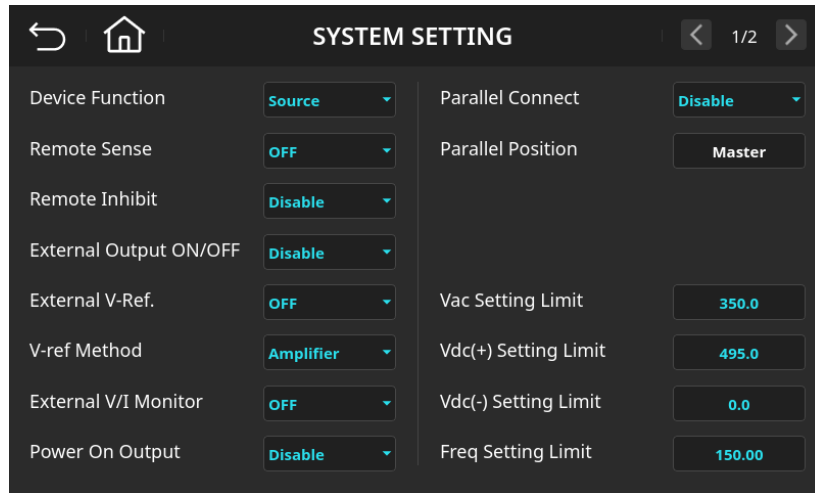



Figure 6-13 System Function Settings Page (Vdc(-) Setting Limit = 0.0)

6.8.3 Output Frequency Setting Limit (Freq Setting Limit)

The Freq Setting Limit restricts the output frequency (Freq) range in the basic mode on the main screen, preventing configurations that exceed the allowable values to ensure operational safety and device stability. If the set value exceeds the limit, the system will display a warning and block the operation.

The following steps describe how to set Freq Setting Limit = 100.00:

1. On the System Function Settings page, tap the icon  for Freq Setting Limit.
2. Enter 1, 0, 0, then press the Enter key ; the value will update to "100.00", as shown in Figure 6-14.

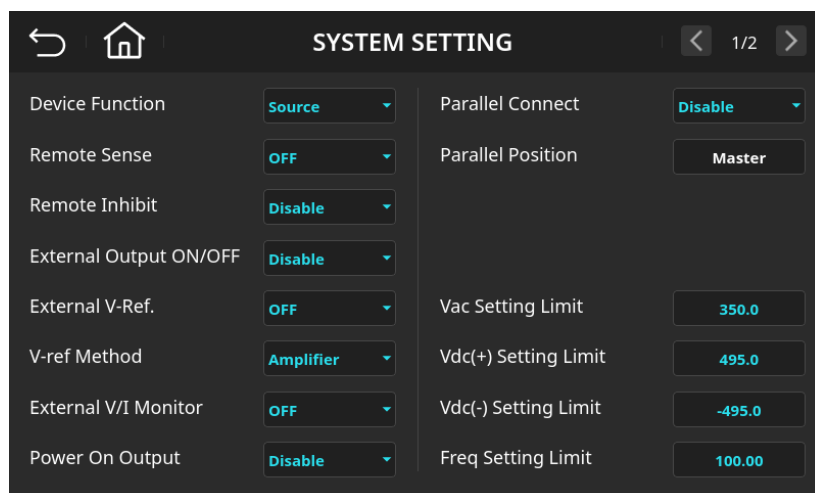

Figure 6-14 System Function Settings Page (Freq Setting Limit = 100.00)

6.9 Screen Brightness Setting (Display Brightness)

This function allows users to adjust the display screen brightness to meet visual needs under different environments. The brightness level can be selected from the System Settings page, offering three adjustable options: Brightest, Medium, and Dimmest. This flexibility helps optimize visibility according to ambient lighting conditions, while also promoting energy savings and extending the screen's service life.

The following steps describe how to set Display Brightness = Medium:

1. On the System Function Settings page, tap the top-right corner to switch to Page 2.
2. Tap the Display Brightness icon **Brightest** to open the dropdown menu.
3. Select "Medium", as shown in Figure 6-15.

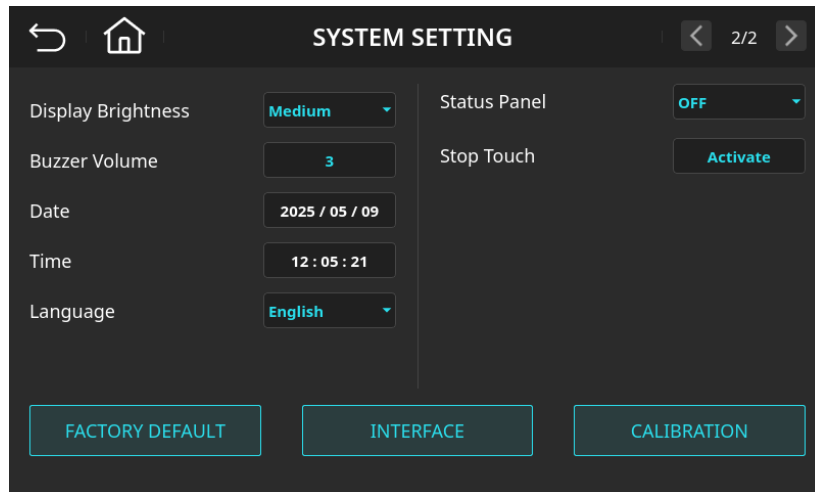
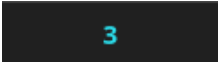



Figure 6-15 System Function Settings Page(Display Brightness=Medium)

6.10 Buzzer Volume Setting

This function allows users to adjust the buzzer volume, which provides audible alerts when the device encounters an abnormal condition or enters a protection state. The system offers volume level options from 0 to 6, where 0 is mute, 1 is the lowest volume, and 6 is the highest. Users can set an appropriate volume level according to their environment to ensure alert sounds are clearly heard.

The following steps describe how to set Buzzer Volume = 1:

1. On the System Function Settings page, tap the top-right corner to switch to Page 2.
2. Tap the Buzzer Volume icon  to open the dropdown menu.
3. Enter 1, then press the Enter  key; the value will update to "1", as shown in Figure 6-16.

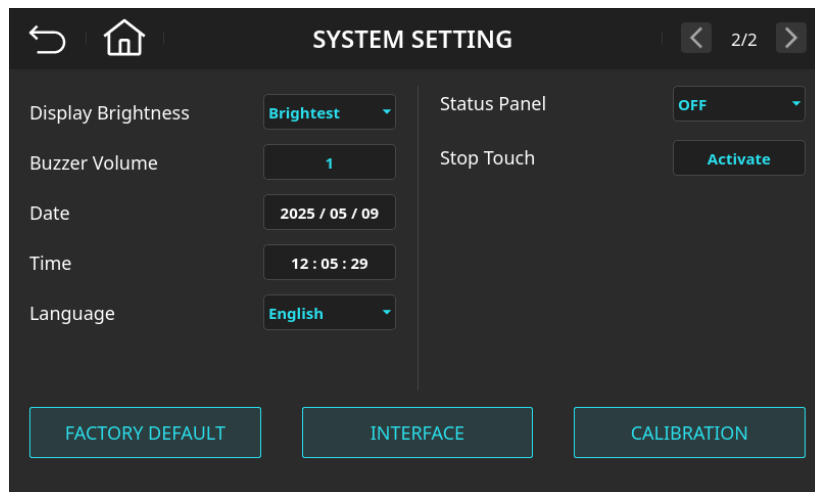

Figure 6-16 System Function Settings Page (Buzzer Volume = 1)

6.11 Date/Time

This function displays the current date and time of the device for user reference. Manual adjustment of this setting is currently not available. When the device is connected to a network, the system will automatically synchronize the date and time with the server to ensure accurate timekeeping, which is useful for logging and tracking usage history.

The following steps describe how to view the current date and time of the device:

On the System Function Settings page, tap the top-right corner to switch to Page 2, as shown in Figure 6-2.

6.12 Language

This function provides a multilingual interface to facilitate operation for users of different language backgrounds. The system currently supports three language options: English, Simplified Chinese, and Traditional Chinese. Users can select their preferred language in the settings page, and the system will instantly switch to the corresponding interface to enhance usability.

The following steps describe how to set the Language to Simplified Chinese:

1. On the System Function Settings page, tap the top-right corner to switch to Page 2.
2. Tap the Language icon  to open the dropdown menu.
3. Select "简体中文 (Simplified Chinese)", as shown in Figure 6-17.



Figure 6-17 System Function Settings Page (Language = Simplified Chinese)

6.13 System Status Monitoring Interface (Status Panel)

The device includes a built-in System Status Monitoring Interface (Status Panel), which provides real-time operational data of key components, such as internal temperature and fan speed. This information is intended for use by maintenance engineers or authorized distributors to assess the health of the equipment. This feature helps identify whether components are operating under abnormal conditions, enabling early detection of potential risks and timely implementation of maintenance or replacement measures. The goal is to extend the device's lifespan and enhance system stability.

Typical applications include:

- Aging assessment after prolonged operation
- Reliability analysis in high-temperature environments
- Fan anomaly alerts and thermal module diagnostics

With this feature, maintenance practices shift toward predictive management, reducing failure rates and minimizing repair costs.

NOTICE

- This function is currently available only to authorized distributors or internal technical personnel and is not accessible to general users by default.

6.14 Touchscreen Lock Function (Stop Touch)

This function allows temporary locking of the touchscreen to prevent accidental touches or unauthorized setting changes. Once enabled, the touchscreen enters a locked state and will no longer respond to user input, while still displaying system information. It is especially suitable for long-term monitoring or during periods requiring stable testing. Unlocking requires a specific confirmation process guided by system prompts to ensure operational safety and integrity of device settings.

The following steps describe how to enable and disable the Touchscreen Lock (Stop Touch) function:

1. On the System Function Settings page, tap the top-right corner to switch to Page 2.

2. Tap the Stop Touch icon **Activate** to enable the touchscreen lock function, as shown in Figure 6-18.
3. On the main screen, tap any area, then click the icon **RELEASE** that appears (as shown in Figure 6-19) to unlock the touchscreen and resume normal operation.

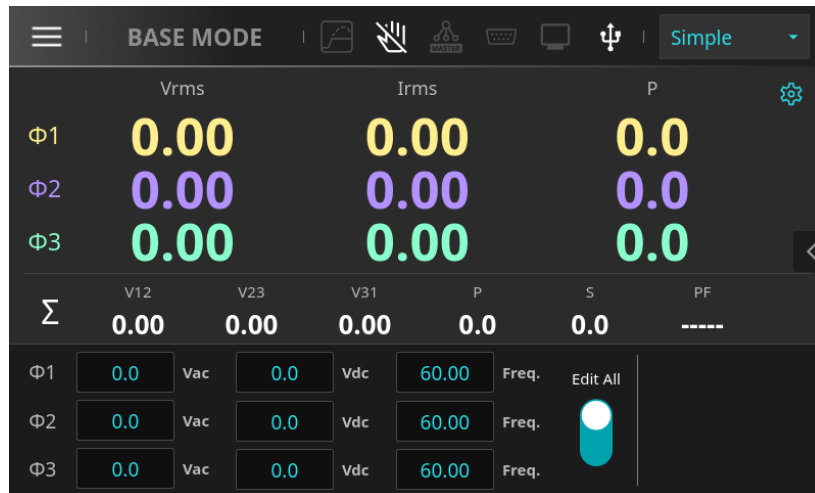

Figure 6-18 Main System Screen (Touch Lock Enabled State)

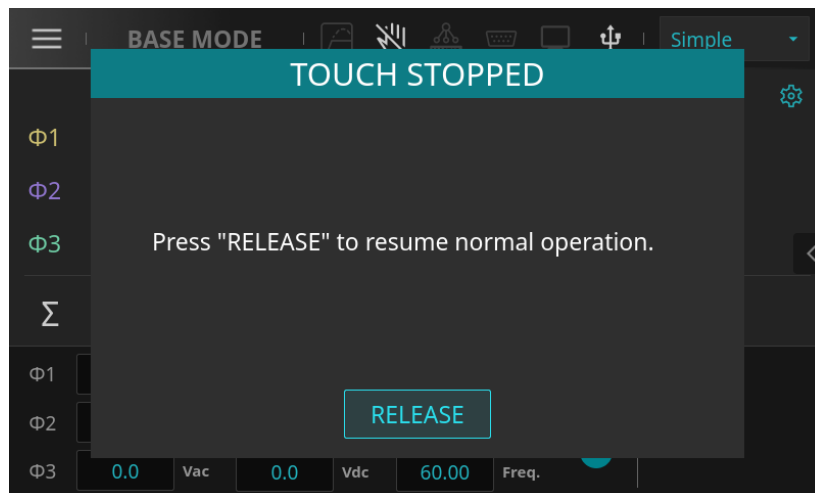
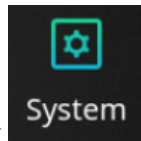

Figure 6-19 Main System Screen (Touch Lock Release Prompt Screen)

6.15 Restore Factory Settings (Factory Default)

This function restores all user-defined parameters on the device (such as output settings, system preferences, language, brightness, volume, etc.) to their factory default values. Users can access this feature from the System Settings page in the main menu to quickly reset the system, which is helpful for resolving configuration errors or returning to the initial state. Before executing the reset, the system will display a confirmation prompt to prevent accidental loss of settings.



Users can tap the function key **System** on the main menu to enter the System Settings page (System) (see Figure 6-2). On Page 2 of this screen, tap the **FACTORY DEFAULT** option at the bottom, enter the correct password, then press the **CONFIRM** key. A confirmation message will appear on the panel (as shown in Figure 6-21), and pressing the **CONFIRM** key again will execute the factory reset.

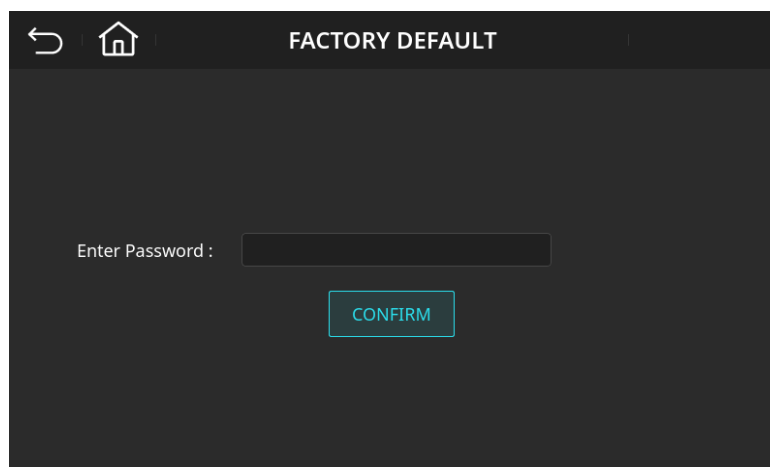

Figure 6-20 Factory Reset Password Entry Screen

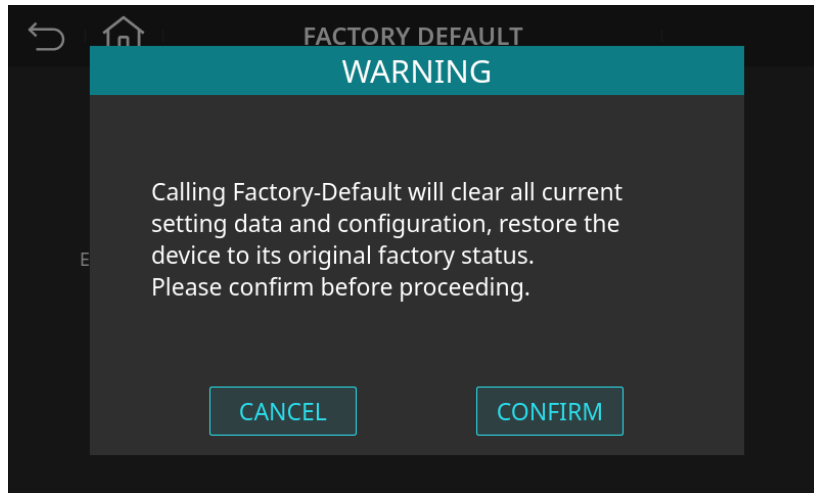

Figure 6-21 Factory Reset Confirmation Prompt Screen

The table below (Table 6-1) lists the system parameter values for the RPS-5045 model after restoring factory settings.

Table 6-1 Factory Default Parameter Table

Item	Default Value	Minimum	Maximum	Resolution	Unit
Output Configuration Settings					
Phase Angle 1-2	120.0	0.0	359.9	0.1	degree-degree
Phase Angle 1-3	240.0	0.0	359.9	0.1	degree-degree
Measure Times	1	1	32	1	
Response Setting	8	1	15	1	
Start Angle	0.0	0.0	359.9	0.1	degree
End Angle	0.0	0.0	359.9	0.1	degree
Vac Slew Rate	1500.00	0.01	2000.00	0.01	V/ms
Vac-Off Slew Rate	1500.00	0.01	2000.00	0.01	V/ms
Vdc Slew Rate	1000.00	0.01	2000.00	0.01	V/ms
Vdc-Off Slew Rate	1000.00	0.01	2000.00	0.01	V/ms
Frequency Slew Rate	1000.00	0.01	1000.00	0.01	Hz/ms
I-Surge Delay	10	0	9999	1	ms
I-Surge Interval	10	0	9999	1	ms
Φ1 R Impedance	0.000	-1.000	1.000	0.001	Ω
Φ1 L Impedance	0	-1000	1000	1	uH
Φ2 R Impedance	0.000	-1.000	1.000	0.001	Ω
Φ2 L Impedance	0	-1000	1000	1	uH

Φ3 R Impedance	0.000	-1.000	1.000	0.001	Ω
Φ3 L Impedance	0	-1000	1000	1	uH
Item	Default Value	Minimum	Maximum	Resolution	Unit
System Function Settings					
Vac Setting Limit	350.0	0.0	350.0	0.1	V
Vdc(+) Setting Limit	495.0	0.0	495.0	0.1	V
Vdc(-) Setting Limit	-495.0	-495.0	0.0	0.1	V
Freq Setting Limit	150.00	30.00	150.00	0.01	Hz
Item	Default Value	Minimum	Maximum	Resolution	Unit
Output Protection Settings					
OCP Φ1	100.0	0.1	102.0	0.1	A
OCP Delay Φ1	3.0	0.0	5.0	0.1	s
OCP Φ2	100.0	0.1	102.0	0.1	A
OCP Delay Φ2	3.0	0.0	5.0	0.1	s
OCP Φ3	100.0	0.1	102.0	0.1	A
OCP Delay Φ3	3.0	0.0	5.0	0.1	s
OPP Φ1	15000	0.1	15300	0.1	VA
OPP Φ2	15000	0.1	15300	0.1	VA
OPP Φ3	15000	0.1	15300	0.1	VA
OVP-Peak Φ1	569.0	5.0	569.0	0.1	V
OVP-Peak Φ2	569.0	5.0	569.0	0.1	V
OVP-Peak Φ3	569.0	5.0	569.0	0.1	V
Current Limit Φ1	100.0	0.1	102.0	0.1	A
Power Limit Φ1	15000	0.1	15300	0.1	VA
Current Limit Φ2	100.0	0.1	102.0	0.1	A
Power Limit Φ2	15000	0.1	15300	0.1	VA
Current Limit Φ3	100.0	0.1	102.0	0.1	A
Power Limit Φ3	15000	0.1	15300	0.1	VA

NOTICE

- The password for restoring factory settings is "0000".

System (System) Parameter Descriptions:

Parameter	Sub-item	Description
Device Function	<ul style="list-style-type: none"> ■ Source ■ Load 	Mode switch for regenerative power system (Power Supply Mode, Load Mode)
Remote Sense	<ul style="list-style-type: none"> ■ ON ■ OFF 	Remote sensing function
Remote Inhibit	<ul style="list-style-type: none"> ■ Enable ■ Disable 	Remote inhibit function
External Output ON/OFF	<ul style="list-style-type: none"> ■ Enable ■ Disable 	Function to control output state via external signal
External V-Ref.	<ul style="list-style-type: none"> ■ ON ■ OFF 	Function for external voltage reference input
V-Ref. Method	<ul style="list-style-type: none"> ■ Amplifier ■ Level 	Coupling method for external voltage reference
External V/I Monitor	<ul style="list-style-type: none"> ■ ON ■ OFF 	Output voltage/current monitoring function
Power On Output	<ul style="list-style-type: none"> ■ Enable ■ Disable 	Output state setting
Parallel Connect	<ul style="list-style-type: none"> ■ Enable ■ Disable 	Parallel operation setting
Parallel Position	<ul style="list-style-type: none"> ■ Master ■ Slave 	Role setting when multiple devices are used in parallel
Vac Setting Limit	0.0 ~ 350.0 V	Output AC voltage setting limit
Vdc(+) Setting Limit	0.0 ~ 495.0 V	Output positive DC voltage setting limit
Vdc(-) Setting Limit	-495.0 ~ 0.0 V	Output negative DC voltage setting limit
Freq Setting Limit	30.0 ~ 150.0 Hz	Output frequency setting limit
Display Brightness	<ul style="list-style-type: none"> ■ Dimmest ■ Medium ■ Brightest 	Screen brightness adjustment
Buzzer Volume	0 ~ 6	Buzzer volume adjustment
Date		Date display
Time		Time display
Language	<ul style="list-style-type: none"> ■ English ■ Simplified Chinese ■ Traditional Chinese 	Language selection
Status Panel	<ul style="list-style-type: none"> ■ Enable ■ Disable 	System status monitoring interface
Stop Touch	Activate	Screen lock function
FACTORY DEFAULT	Refer to Chapter 6.15	Restore factory settings
INTERFACE	Refer to Chapter 12	Configure communication interface options
CALIBRATION	Refer to Chapter 8	System calibration

7 Protection List Description

This section introduces the protection mechanisms built into the power system, which ensure that the equipment can continue to operate safely under abnormal or fault conditions, preventing internal component damage and safeguarding both the user and the device under test (DUT). The system employs multiple layers of protection, including both hardware and software, to address various possible abnormal situations. When the device triggers a protection mechanism, the system will display an alarm message and, depending on the fault type, may cut off the output relay. The protection mechanisms are classified as follows:

■ Manual-Reset Protection

When the device enters manual-reset protection mode, the user must manually clear the fault, then press the protection clear button  on the panel to remove the protection state. Once cleared, the system resumes normal operation. The protection status is displayed on the screen as shown in Figure 7-1. Detailed descriptions of the protection types can be found in Table 7-1.

■ Latched Protection

When the device enters latched protection mode, it must be restarted to restore the power system in order to clear the protection state and resume normal operation. The above mechanisms ensure that the system has the ability to withstand abnormal or fault conditions, thereby improving equipment reliability and operational safety. The protection status is displayed on the screen as shown in Figure 7-2. Detailed explanations of the protection mechanisms are provided in Table 7-2.

NOTICE

- When the regenerative power system cannot operate normally, please refer to the troubleshooting guide in the protection mechanism tables (Table 7-1 and Table 7-2) and follow the corresponding steps to eliminate the fault. If the problem persists after completing all troubleshooting steps, please contact the customer service center or your local authorized distributor for further technical support.

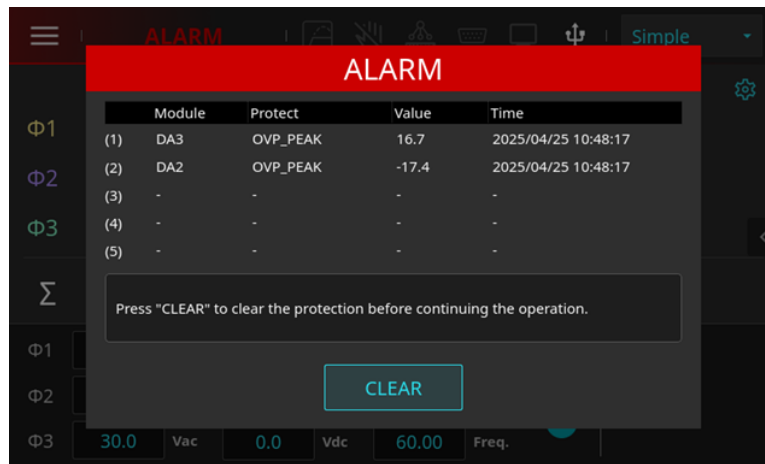

Figure 7-1 Regenerative Power System Recoverable Protection Diagram

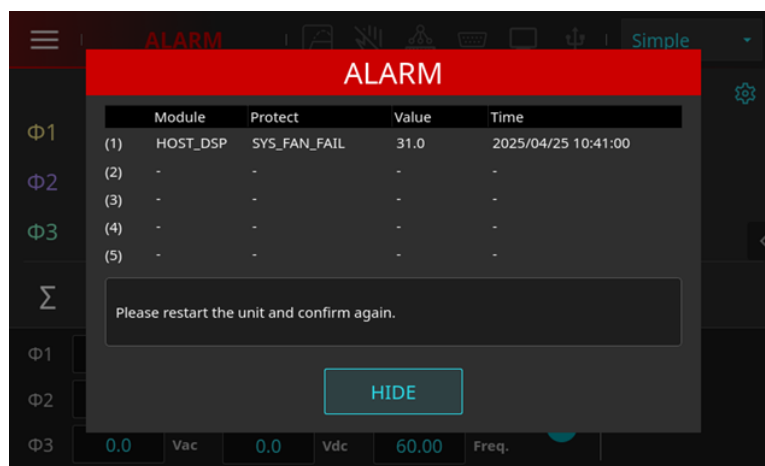

Figure 7-2 Regenerative Power System Non-Recoverable (Latch) Protection Diagram

Table 7-1 Recoverable Protection List

Protection Message	Protection Description	Possible Cause	Troubleshooting
OVP_PEAK(DA Φ 1/2/3)	When the output voltage exceeds the system-set voltage limit	1. OVP parameter setting mismatch	1. Check if OVP parameter is properly set
OVP_PEAK_CYC(DA 1/2/3)	When the output voltage peak exceeds the instantaneous voltage limit	2. UUT transient load spike too large 3. Inductive load feedback 4. UUT capacitive load too large	2. Verify UUT operation/load 3. Remove UUT abnormal behavior 4. Confirm UUT capacitive load characteristics
OCP_PEAK(DA 1/2/3)	When the output current exceeds the rated instantaneous current limit	1. OCP parameter setting mismatch 2. UUT startup current too large 3. UUT transient load	1. Check if OCP parameter is properly set 2. Adjust OCP Delay parameter 3. Remove UUT abnormal

OCP(DA 1/2/3)	When the output current exceeds the system-set current limit	abnormality 4. UUT capacitive load too large	behavior 4. Confirm UUT capacitive load characteristics
OPP_PEAK(DA 1/2/3)	When the output power exceeds the instantaneous power limit	1. OPP parameter setting mismatch 2. UUT startup power too large 3. UUT transient load abnormality	1. Check if OPP parameter is properly set 2. Adjust OPP Delay parameter 3. Remove UUT abnormal behavior
OPP(DA 1/2/3)	When the output power exceeds the system-set power limit	4. UUT capacitive load too large	4. Confirm UUT capacitive load characteristics
VSENSE_OFF_OVP(DA 1/2/3)	When the locally measured voltage is higher than the set voltage	1.Abnormality in the output contact relay 2.Abnormality in the relay drive power supply or wiring 3. Internal feedback or drive circuit abnormality in the DC/AC module	Please contact your local authorized distributor or technical support center for further assistance.
VSENSE_OFF_UVP(DA 1/2/3)	When the locally measured voltage is lower than the set voltage	4. Communication abnormality between the DC/AC module's digital control board and the system	
VSENSE_ON_OVP(DA 1/2/3)	When remote sensing is enabled and the remote sense voltage is higher than the set voltage	1. Improper or poor connection of the remote sensing line 2. Remote sensing line miswiring 3. Abnormality in the output contact relay 4. Abnormality in the relay drive power supply or wiring	1. Confirm proper connection of the remote sensing line and correct polarity 2. Use limited-length cables and avoid excessive wire lengths
VSENSE_ON_UVP(DA 1/2/3)	When remote sensing is enabled and the remote sense voltage is lower than the set voltage	5. Internal feedback or drive circuit abnormality in the DC/AC module 6. Communication abnormality between the DC/AC module's digital control board and the system	3. If the problem persists, contact your local authorized distributor or technical support center for further assistance
VSENSE_OFF_FAIL(DA 1/2/3)	When the voltage at both output terminals exceeds the allowable range with the output relay disconnected	1. Abnormality in the output contact relay 2. Abnormality in the relay drive power supply or wiring 3. Internal feedback or drive circuit abnormality in the DC/AC module	1. Confirm proper connection of the remote sensing line and correct polarity 2. Use limited-length cables and avoid excessive wire lengths
VSENSE_ON_FAIL(DA 1/2/3)	When remote sensing is enabled and the voltage at both output terminals exceeds the allowable range	4. Communication abnormality between the DC/AC module's digital control board and the system	3. If the problem persists, contact your local authorized distributor or technical support center for further assistance

SET_OVP	When the set voltage exceeds the system limit	1. Output voltage parameter setting error	1. Check whether the output voltage parameter setting is reasonable
INT_TEST_FAIL(DA 1/2/3)	Startup self-test abnormality	1. DC/AC module base circuit abnormality 2. DC/AC power module or drive circuit abnormality 3. Communication abnormality between the DC/AC module digital control board and the system	Please contact your local authorized distributor or technical support center for further assistance
OUTPUT_SHORT(DA 1/2/3)	Output short-circuit protection	1. UUT startup surge too large 2. UUT short circuit or internal abnormality 3. Output terminal connection line or internal wiring abnormality	1. Check for external short circuits 2. Remove UUT short-circuit fault and retest 3. Confirm if external connection wiring is correct
OVP_VR(DA 1/2/3)	Output voltage waveform distortion exceeds the voltage limit	1. Output voltage waveform distortion component exceeds system limit 2. DC/AC module base circuit abnormality 3. DC/AC power module output filter circuit abnormality 4. Communication abnormality between the DC/AC module's digital control board and the system	1. Check if the output voltage distortion component setting is appropriate 2. If the problem persists, contact your local authorized distributor or technical support center for further assistance
IO_UNBALANCE(DA 1/2/3)	When operating in single-phase mode, the output current imbalance among modules exceeds the allowable range	1. Abnormality in the output terminal configuration and connection 2. Abnormality in the output contact relay 3. DC/AC module base circuit abnormality 4. DC/AC power module output filter circuit abnormality 5. Communication abnormality between the DC/AC module's digital control board and the system	1. Confirm correct external wiring and terminal connection 2. If the problem persists, contact your local authorized distributor or technical support center for further assistance
CALIBRATION_ERR(DA 1/2/3)	Calibration values are missing internally or errors occur during calibration	1. Calibration process failed or error 2. DC/AC module base circuit abnormality	1. Reboot the equipment and perform calibration again 2. If the problem persists, contact your local authorized distributor or technical support center for further assistance
REMOTE_INHIBIT_PRO	When the remote inhibit function is enabled, protection	N/A	N/A

	is triggered when a disconnection or abnormality is detected		
RCP	When the system detects abnormal reverse power	<ol style="list-style-type: none"> 1. Internal abnormality of the UUT (Unit Under Test) 2. UUT generates reverse power during transient load change 3. Improper wiring or polarity at the output terminal connection 	<ol style="list-style-type: none"> 1. Remove the UUT and confirm input operation characteristics 2. Confirm the UUT transient characteristics 3. Verify the correctness of the output terminal wiring and UUT connection

NOTICE

- RCP (Reverse Current Protection) is a dedicated protection mechanism exclusively available in the RPS-5000 Series Model S (the model without regenerative function).

Table 7-2 Non-Recoverable (Latched) Protection List

Protection Message	Protection Description	Possible Cause	Troubleshooting
SYS_FAN_FAIL	System fan abnormal protection	<ol style="list-style-type: none"> 1. Fan clogged with dust or obstructed operation 2. Fan failure or performance degradation 3. Fan power supply or connection abnormality 4. Fan control circuit malfunction 	<ol style="list-style-type: none"> 1. Check whether the fan is obstructed or regularly clean the filter screen. 2. Please contact your local authorized distributor or technical support center for further assistance.
FAN_FAIL_L(AD 1/2/3) FAN_FAIL_R(AD 1/2/3)	AC/DC power module fan abnormal protection		
FAN_FAIL(DA 1/2/3)	DC/AC power module fan abnormal protection		
TR_OTP	Transformer internal over-temperature protection	<ol style="list-style-type: none"> 1. High ambient operating temperature 2. Fan clogging or obstructed operation 3. Low-efficiency transformer abnormality 4. Power module fault or sensing circuit abnormality 	<ol style="list-style-type: none"> 1. Improve the thermal environment conditions 2. Inspect the fan for clogging and clean the filter screen 3. Contact your local authorized distributor or technical support center for further assistance
OTP(AD 1/2/3)	AC/DC power module internal over-temperature protection		
OTP(DA 1/2/3)	DC/AC power module internal over-temperature protection		
OVP_VRN_PEAK(AD 1/2/3) OVP_VSN_PEAK(AD 1/2/3) OVP_VTN_PEAK(AD 1/2/3)	Input voltage exceeds instantaneous peak limit	<ol style="list-style-type: none"> 1. Abnormal input voltage or power source abnormality 2. AC/DC module input detection abnormality 	<ol style="list-style-type: none"> 1. Check the wiring and confirm that the input power source meets the device's rated voltage range 2. Contact your local

OVP_VRN(AD 1/2/3) OVP_VSN(AD 1/2/3) OVP_VTN(AD 1/2/3)	Input voltage exceeds limit value		authorized distributor or technical support center for further assistance
UVP_VRN(AD 1/2/3) UVP_VSN(AD 1/2/3) UVP_VTN(AD 1/2/3)	Input voltage falls below limit value	1. Abnormal input power source or wiring 2. AC/DC module input fuse abnormality 3. DC/AC module base circuit abnormality	1. Check the wiring and confirm that the input power source meets the device's rated voltage range 2. Contact your local authorized distributor or technical support center for further assistance
AC_UNBALANCE(AD 1/2/3)	When input voltage imbalance or phase loss occurs	1. Three-phase input power imbalance or connection wiring abnormality 2. Input power phase loss 3. AC/DC module input fuse abnormality 4. AC/DC module base circuit abnormality	1. Check the wiring and confirm that the input power source meets the device's rated voltage range 2. Contact your local authorized distributor or technical support center for further assistance
FREQ_ERR(AD 1/2/3)	When the input voltage frequency exceeds the limit value	1. Abnormal input power frequency 2. AC/DC module base circuit abnormality	1. Check the wiring and confirm that the input power source meets the device's rated voltage range 2. Contact your local authorized distributor or technical support center for further assistance
OCP_IR_PEAK(AD 1/2/3) OCP_IS_PEAK(AD 1/2/3) OCP_IT_PEAK(AD 1/2/3)	When the input current exceeds the instantaneous limit value	1. Instantaneous output power too high 2. AC/DC module base circuit abnormality	1. Remove the UUT and confirm its operation characteristics 2. Contact your local authorized distributor or technical support center for further assistance
OCP_IR(AD 1/2/3) OCP_IS(AD 1/2/3) OCP_IT(AD 1/2/3)	When the input current exceeds the limit value		
OPP_PEAK(AD 1/2/3)	When the input power exceeds the instantaneous limit value	1. Instantaneous output power too high 2. AC/DC module base circuit abnormality	1. Remove the UUT and confirm its operation characteristics 2. Contact your local authorized distributor or technical support center for further assistance
OPP_PR(AD 1/2/3) OPP_PS(AD 1/2/3) OPP_PT(AD 1/2/3)	When the input power exceeds the limit value		

BUS_OVP_PEAK(AD 1/2/3)	When the AC/DC power module bus voltage exceeds the instantaneous limit value	1. UUT capacitive load energy feedback 2. AC/DC module base circuit abnormality	1. Remove the UUT and confirm its operation characteristics 2. Contact your local authorized distributor or technical support center for further assistance
BUS_OVP(AD 1/2/3)	When the AC/DC power module bus voltage exceeds the limit value		
BUS_UVP_PEAK(AD 1/2/3)	When the AC/DC power module bus voltage falls below the instantaneous limit value	1. Instantaneous output power too high 2. AC/DC module base circuit abnormality 3. AC/DC power module drive circuit abnormality 4. AC/DC module digital control abnormality	1. Remove the UUT and confirm its operation characteristics 2. Contact your local authorized distributor or technical support center for further assistance
BUS_UVP(AD 1/2/3)	When the AC/DC power module bus voltage falls below the limit value		
BUS_OCP_PEAK(AD 1/2/3)	When the AC/DC power module bus current exceeds the instantaneous limit value	1. Instantaneous output power too high 2. AC/DC module base circuit abnormality 3. AC/DC module drive circuit abnormality 4. AC/DC module digital control board abnormality 5. AC/DC module communication abnormality	1. Remove the UUT and confirm its operation characteristics 2. Contact your local authorized distributor or technical support center for further assistance
BUS_OCP(AD 1/2/3)	When the AC/DC power module bus current exceeds the limit value		
BUS_OPP_PEAK(AD 1/2/3)	When the AC/DC power module bus power exceeds the instantaneous limit value		
BUS_OPP(AD 1/2/3)	When the AC/DC power module bus power exceeds the limit value		
VDC_ERR(AD 1/2/3)	Abnormal output voltage of AC/DC power module	1. Abnormality in the AC/DC module digital control board	Contact your local authorized distributor or technical support center for further assistance
DSP_HW_ERR(AD 1/2/3)	Abnormality in the digital control board of AC/DC power module		
DSP_HW_ERR(DA 1/2/3)	Abnormality in the digital control board of DC/AC power module	1. Abnormality in the DC/AC module digital control board	
AD_AUX_ERR	Abnormal auxiliary power supply of power module	1. Auxiliary power supply abnormality in the module 2. Digital control board abnormality	
CONTACT_RLY_FAIL	Input contact relay abnormal protection	1. Input contact relay abnormality 2. Relay drive power supply circuit abnormality	Contact your local authorized distributor or technical support center for further assistance
OUTPUT_RLY_FAIL	Output relay abnormal protection	1. Output relay abnormality 2. Relay drive power supply circuit abnormality	
SYS_SW_OFF	System main switch abnormal protection	1. System main switch abnormality	

SYS_PON_FAIL	System startup sequence abnormal protection	<ol style="list-style-type: none">1. Low voltage power supply abnormality2. Main relay abnormality3. Relay drive power supply circuit abnormality4. AC/DC module base circuit abnormality5. AC/DC module drive circuit abnormality6. AC/DC module digital control board abnormality	
--------------	---	--	--

8 Calibration and Verification

8.1 Calibration and Verification

The regenerative grid simulator features a highly efficient and user-friendly built-in calibration mechanism that ensures output accuracy and measurement precision without requiring the removal of the outer casing. This greatly enhances the convenience and safety of the calibration process. Users can complete the calibration procedure simply by following the step-by-step instructions—no complicated manual adjustments are needed.

To perform calibration, you will need a high-precision Digital Voltmeter (DVM), Digital Current Ammeter (DCA), or Power Analyzer, along with a suitable load. Connect the calibration instruments according to the device instructions; see Figure 8-1 for reference. Calibration items include output voltage and output current. It is not necessary to calibrate all three phases simultaneously—users may choose to calibrate a single phase independently based on their needs, ensuring consistency and stability across all outputs. Additionally, the built-in calibration parameters can be compared with those of standard test equipment to ensure compensation accuracy. Fine adjustments can be made digitally via software, further reducing manual calibration errors and enhancing overall test reliability.

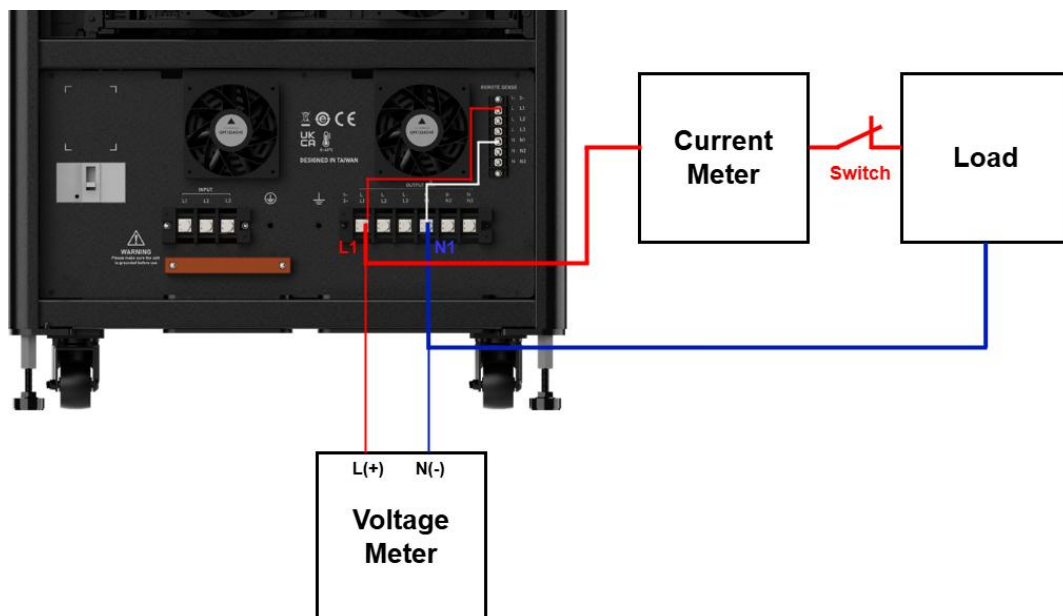

Figure 8-1 Calibration Equipment Wiring Diagram (L1/N1)

NOTICE



- Before executing the calibration procedure, allow the equipment to warm up for at least 20 minutes under an ambient temperature of $25^{\circ}\text{C} \pm 5^{\circ}\text{C}$ (standard operating conditions). This ensures thermal stability of internal circuits, thereby improving the accuracy and consistency of the calibration results.
- Please refer to Section 3.4.1 for proper wiring instructions. During calibration, ensure that output terminals L1/L2/L3/N1/N2/N3 are correctly connected to the Remote Sense terminals; otherwise, the calibration process may not function correctly.
- The switch shown in Figure 8-1 is primarily used during the voltage calibration process to ensure the load is completely disconnected, preventing interference with the calibration results.

8.2 Entering the Calibration Procedure

This section explains the calibration procedure of the instrument. During calibration, all operational instructions will be displayed on the instrument screen. Please strictly follow the on-screen guidance to ensure calibration accuracy. The following calibration items should be performed periodically:

1. Output voltage setting accuracy
2. Voltage measurement accuracy
3. Current limit setting accuracy
4. Current measurement accuracy

The instrument supports user-executed calibration; however, to ensure traceability and compliance with standard regulations, it is recommended to have the calibration performed by a certified calibration laboratory.

Users can access the System Function Settings page by pressing the  function key from the main menu (refer to Figure 6-2). On this page, select the  option at the bottom and enter the password to enter the calibration procedure screen.

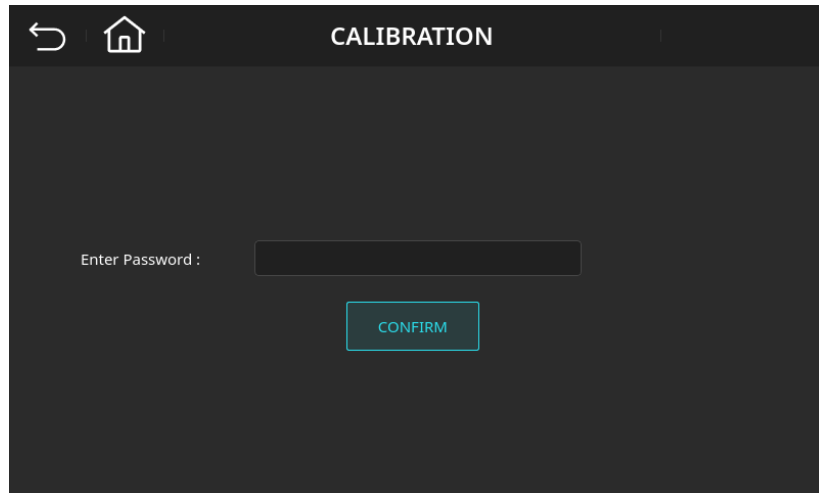

Figure 8-2 Calibration Password Input Screen

NOTICE

- The password to enter the calibration procedure is "8888".
- Before calibrating the regenerative power system, users should carefully read the calibration procedure. Failure to follow the correct steps may result in the loss of certain memory data.

After entering the correct password, press the **CONFIRM** key. The panel will display a prompt message (as shown in Figure 8-3) indicating that the calibration procedure must be performed in three-phase mode. If the device was previously in single-phase mode, please remove the short-circuit fixture connected to the output terminals (L1/L2/L3) before pressing **CONFIRM** again to proceed with the calibration.

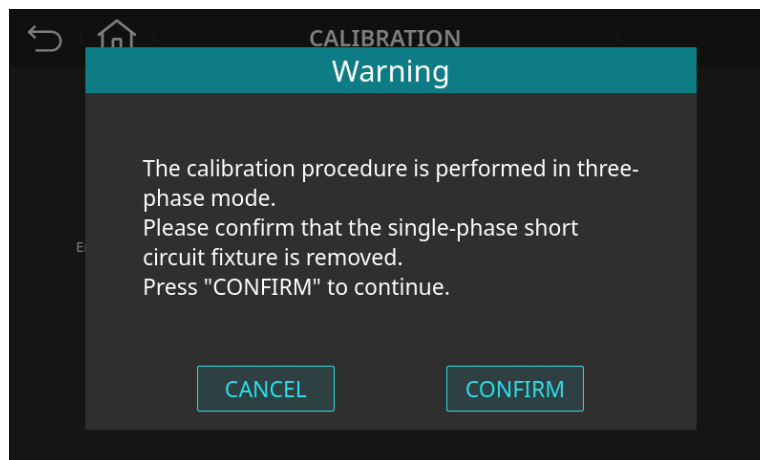

Figure 8-3 Warning Page Before Entering Calibration Screen

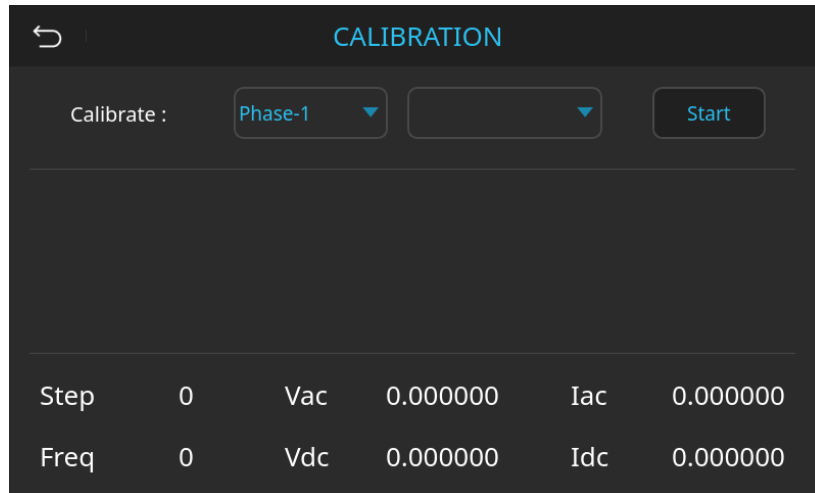

Figure 8-4 Calibration Procedure Main Screen

After entering the calibration main screen, as shown in Figure 8-4, users can select a specific phase for independent calibration based on their needs. They can also choose between voltage calibration or current calibration. The parameter selection is described as follows:

Calibration Procedure (Calibration) Parameter Descriptions:

Parameter	Sub-item	Description
Calibration Phase	■ Phase-1	Phase-1: First phase
	■ Phase-2	Phase-2: Second phase
	■ Phase-3	Phase-3: Third phase
Calibration Item	■ Volt-Offset	Volt-Offset: Voltage offset value
	■ Volt-DC	Volt-DC: DC voltage value
	■ Volt-AC	Volt-AC: AC voltage value
	■ Curr-Offset	Curr-Offset: Current offset value
	■ Curr-AC	Curr-AC: AC current value

8.2.1 Voltage Setting and Measurement Calibration

Referencing Section 8.2, after entering the correct password and accessing the calibration main screen, an example of calibrating the output of Phase 1 in the regenerative power system is described as follows:

A. Voltage Offset Calibration

The first calibration point is for the DC offset of the output voltage. On the calibration main screen, click the

icon  for selecting the calibration phase to open the drop-down menu. Select "Phase-1", then

click the icon  for selecting the calibration item to open its drop-down menu, and select Volt-Offset, as shown in Figure 8-5.

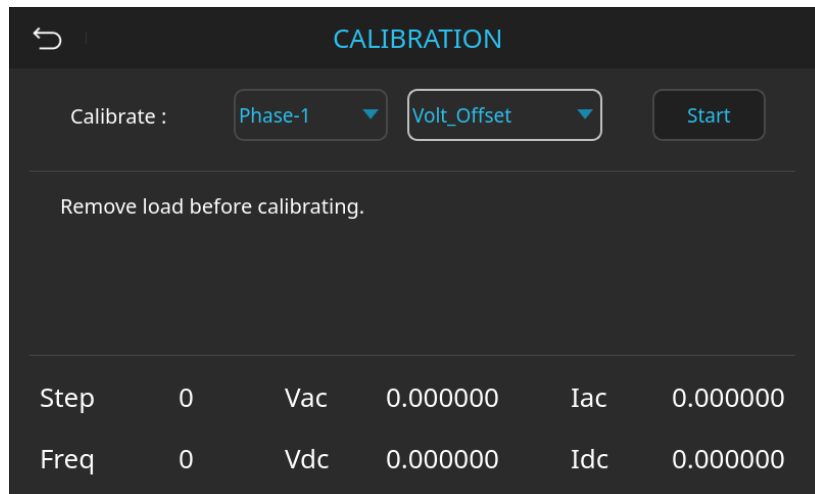

Figure 8-5 Output Voltage Offset Calibration Screen for Phase 1

Before starting the output voltage offset calibration for Phase 1, a prompt will appear on the screen (as shown in Figure 8-6). Please set the voltmeter to Vdc mode, ensure that there is no load connected to the output terminals, and then press the **CONFIRM** key to begin output.

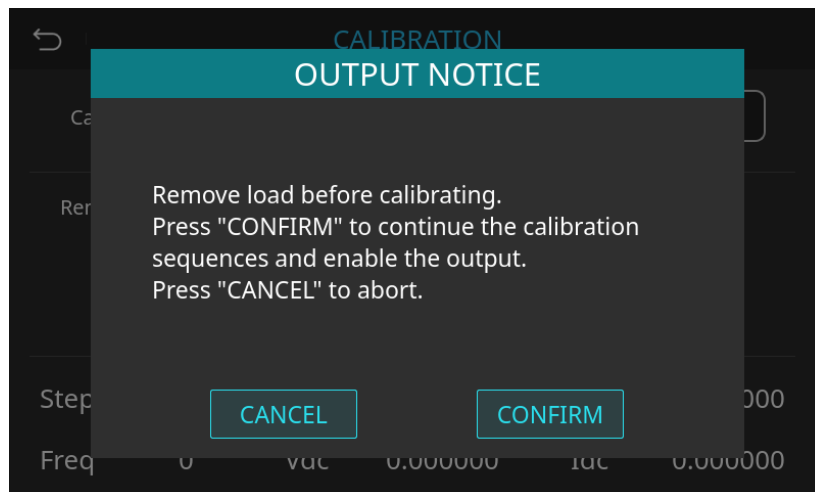

Figure 8-6 Notification Screen for Output Voltage Offset Calibration Procedure

NOTICE

- V The Vdc offset value can be either positive or negative.

- During all steps of voltage setting and measurement calibration, it is essential to ensure that the load is completely disconnected.

The user should use a Digital Voltmeter (DVM) to measure the DC output voltage (Vdc) of the regenerative power system. The reading should be in volts (V). After measurement, enter the measured value into the DVM input field on the screen.

← CALIBRATION

Calibrate : Phase-1 Volt_Offset Start

Key in the DVM measured Vdc, then press "Enter".
Tuning the rotary knob to make Vdc value within $\pm 10\text{mV}$, then press "Next".

DVM :

Step	1	Vac	0.129968	Iac	0.000000
Freq	50	Vdc	-0.119678	Idc	0.000000

Figure 8-7 Output Voltage Offset Calibration Procedure Screen

If the Digital Voltmeter (DVM) reading is -0.140V, please enter the value "-0.140" in the DVM input field on the screen (as shown in Figure 8-8). After entering the value, **do not** press the **Next >>** key immediately. Use the front panel knob to finely adjust the output until the DVM reading stabilizes within $\pm 10\text{ mV}$, then press the **Next >>** key to proceed with the calibration.

← CALIBRATION

Calibrate : Phase-1 Volt_Offset Start

Instruction 3

DVM :

Next >>

Step	2	Vac	0.228354	Iac	0.081690
Freq	50	Vdc	0.000021	Idc	-0.144432

Figure 8-8 Output Voltage Offset Calibration – Fine Adjustment Using Knob

At this point, please wait for approximately 5 seconds, then verify that the Vdc reading on the calibration screen has stabilized within ± 10 mV, as shown in Figure 8-9. Once confirmed, press the **Next >>** key to complete the output voltage offset calibration procedure, as illustrated in Figure 8-10.

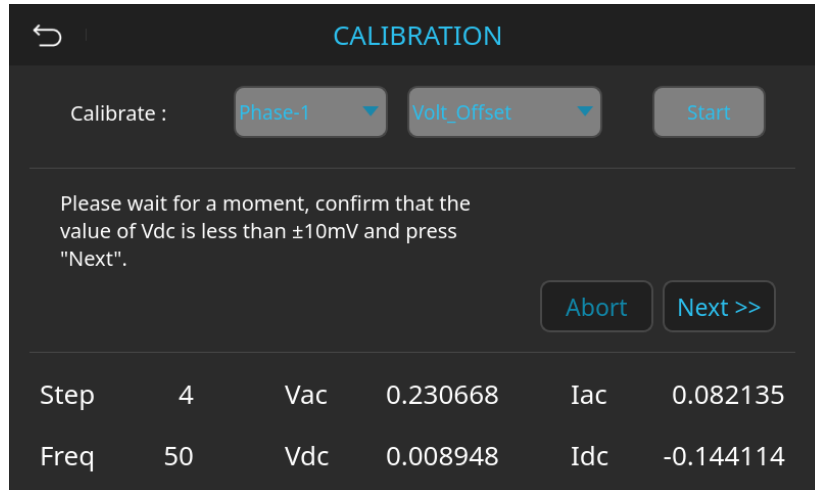

Figure 8-9 Output Voltage Offset Calibration – Confirm Vdc Reading on Calibration Screen

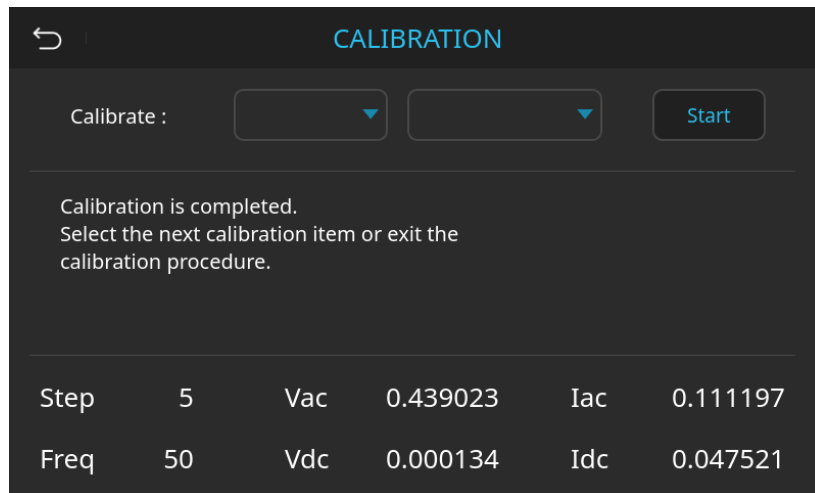



Figure 8-10 Output Voltage Offset Calibration Completion Screen

B. DC Voltage Calibration

The second calibration point is for DC output voltage calibration. On the calibration main screen, click the **Phase-1** icon for selecting the calibration phase to open the drop-down menu, and select “Phase-1”.

Then click the icon  for selecting the calibration item to open its drop-down menu, and select Volt-DC, as shown in Figure 8-11.

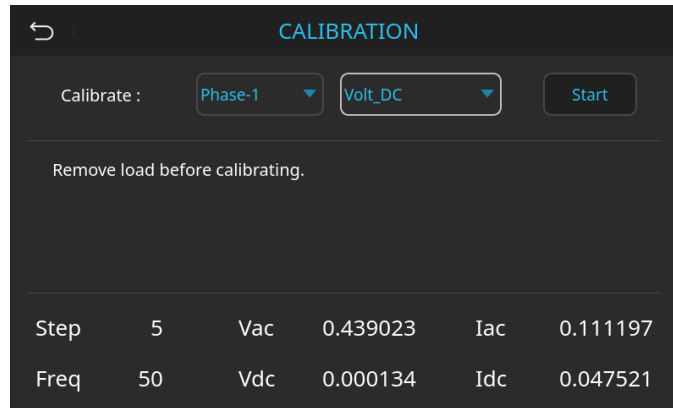



Figure 8-11 Output DC Voltage Calibration Screen for Phase 1

Before starting the DC output voltage calibration for Phase 1, a prompt will appear on the screen (as shown in Figure 8-6). Please set the voltmeter to Vdc mode, ensure that there is no load connected to the output terminals, and then press the  key to begin output.

The user should use a Digital Voltmeter (DVM) to measure the DC output voltage (Vdc) of the regenerative power system. At this stage, the output voltage is approximately 10Vdc (as shown in Figure 8-12), and the reading should be taken in volts (V). After measurement, enter the value into the DVM input field on the screen. Next, the device will automatically continue to output approximately 200Vdc (as shown in Figure 8-13). The user should again measure this value using the DVM and enter the measured result into the DVM input field on the screen. This will complete the DC output voltage calibration procedure, as shown in Figure 8-10.

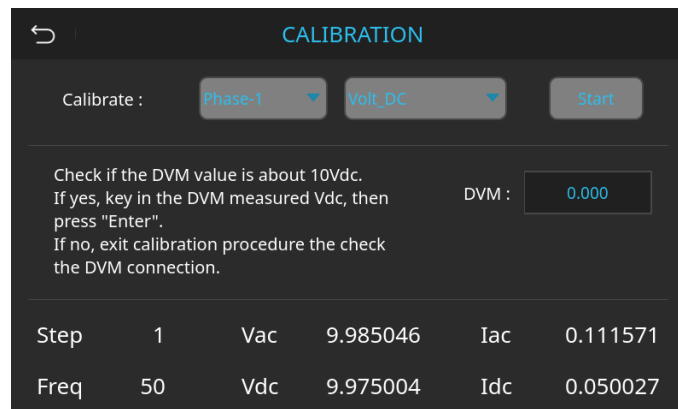

Figure 8-12 DC Output Voltage Calibration Procedure – Output at 10Vdc

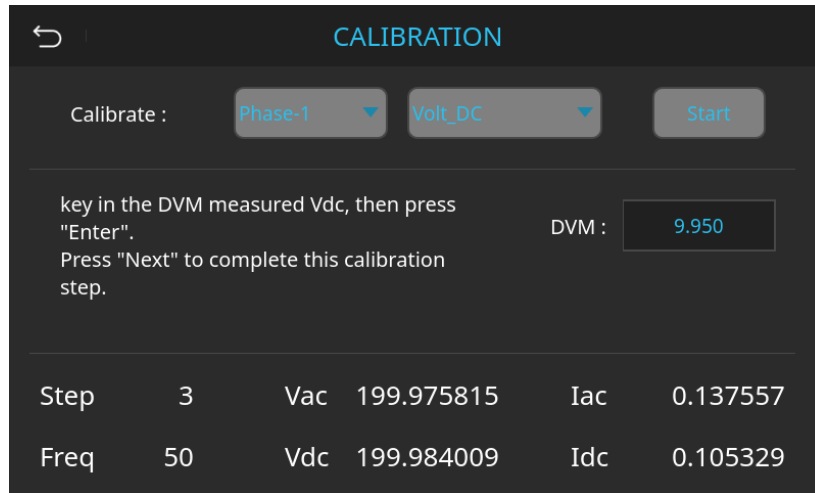

Figure 8-13 DC Output Voltage Calibration Procedure – Output at 200Vdc

CAUTION

- To prevent users from entering incorrect readings, a calibration protection mechanism will be triggered if the entered value significantly deviates from the measured value displayed on the panel. Users must carefully verify and confirm the accuracy and validity of the input value to ensure the calibration process proceeds smoothly.

C. AC Voltage Calibration

The third calibration point is for AC output voltage calibration. On the calibration main screen, click the

Phase-1

icon for selecting the calibration phase to open the drop-down menu and select "Phase-1".

Then click the icon for selecting the calibration item to open its drop-down menu, and select Volt-AC, as shown in Figure 8-14.

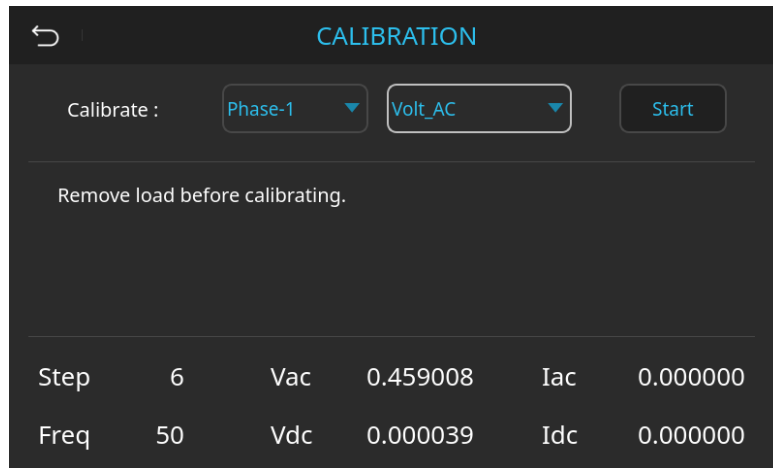

Figure 8-14 Output AC Voltage Calibration Screen for Phase 1

Before starting the AC output voltage calibration for Phase 1, a prompt will appear on the screen (as shown in Figure 8-6). Set the voltmeter to Vac mode, ensure there is no load connected to the output terminals, and then press the **CONFIRM** key to begin output.

The user should use a Digital Voltmeter (DVM) to measure the AC output voltage (Vac) of the regenerative power system. At this stage, the output voltage will be approximately 10Vac (as shown in Figure 8-15), and the reading should be taken in volts (V). After measurement, enter the value into the DVM input field on the screen. Next, the device will automatically output approximately 100Vac, with the frequency sweeping from 100Hz to 3000Hz (as shown in Figure 8-16). During this step, no user action is required. After about 25 seconds, the screen will display a message indicating that the AC setting has been calibrated.

Then, press the **Next >>** key to complete the AC output voltage calibration, as shown in Figure 8-17.

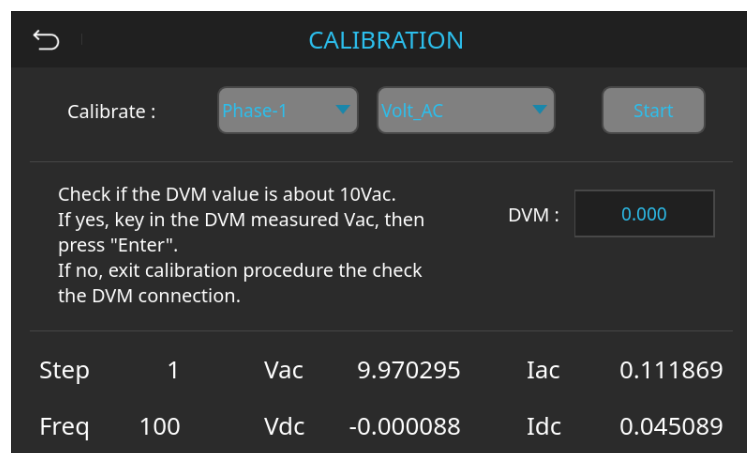

Figure 8-15 AC Output Voltage Calibration Procedure – Output at 10Vac

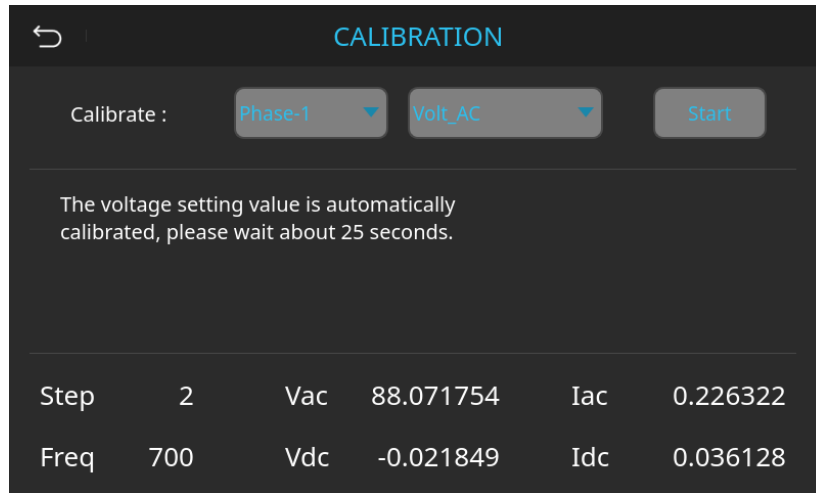

Figure 8-16 AC Output Voltage Calibration Procedure – AC Voltage Sweep Output

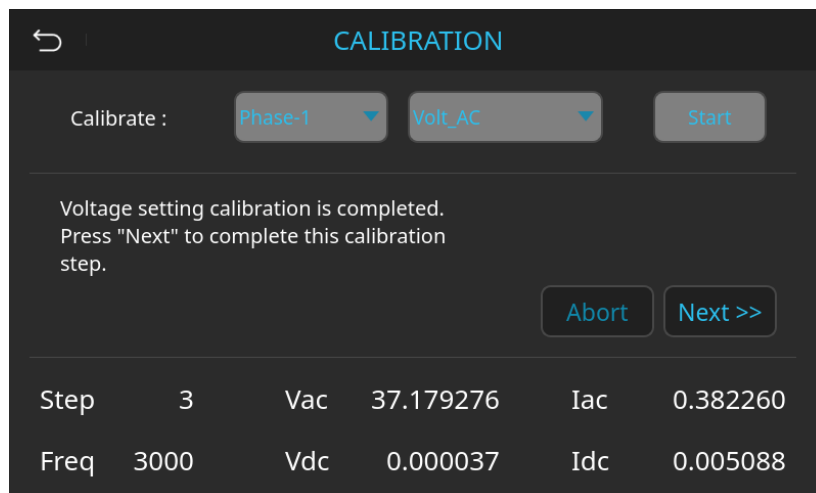



Figure 8-17 AC Output Voltage Calibration Completion Screen

8.2.2 Current Measurement Calibration

Referencing Section 8.2, after entering the correct password and accessing the calibration main screen, the following is an example of calibrating the output of Phase 1 in the regenerative power system:

A. Current Offset Calibration

The first calibration point is for the DC offset of the output current.

On the calibration main screen, click the icon  to open the phase selection drop-down menu and select “Phase-1”. Then, click the icon  to open the calibration item drop-down menu and select Curr-Offset, as shown in Figure 8-18.

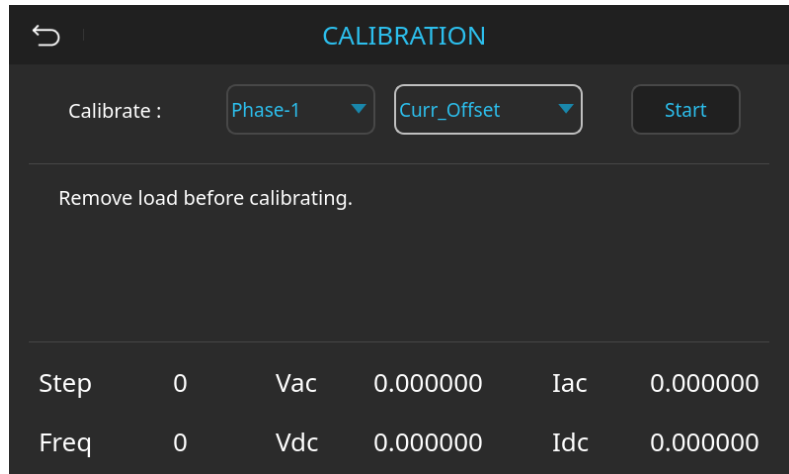



Figure 8-18 Output Current Offset Calibration Procedure Screen

Before starting the output current offset calibration for Phase 1, a prompt will appear on the screen (as shown in Figure 8-6). Please ensure that there is no load connected to the output terminals, then press the  key to begin output.

In this step, no user action is required. Please wait approximately 5 seconds, and confirm that the Idc reading on the calibration screen has stabilized within ± 5 mA. Then press the  key to complete the output current offset calibration procedure, as shown in Figure 8-19.

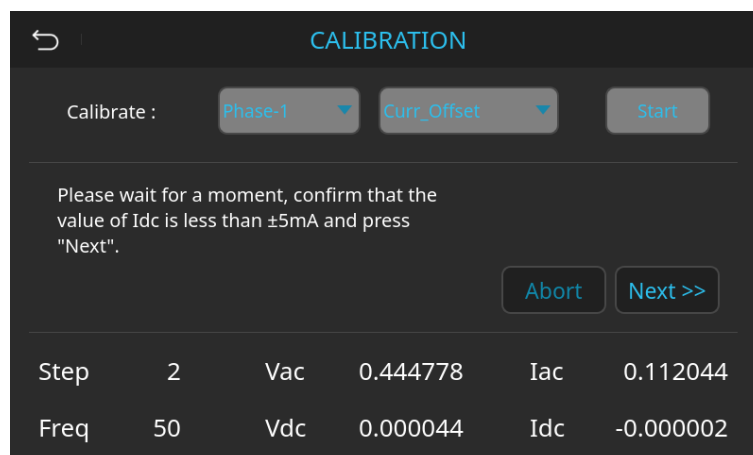



Figure 8-19 Output Current Offset Calibration Procedure – Confirm Idc Reading

B. AC Current Calibration

The second calibration point is for AC output current calibration. On the calibration main screen, click the

icon  to open the calibration phase drop-down menu and select "Phase-1". Then, click the icon  to open the calibration item drop-down menu and select Curr-AC, as shown in Figure 8-20.

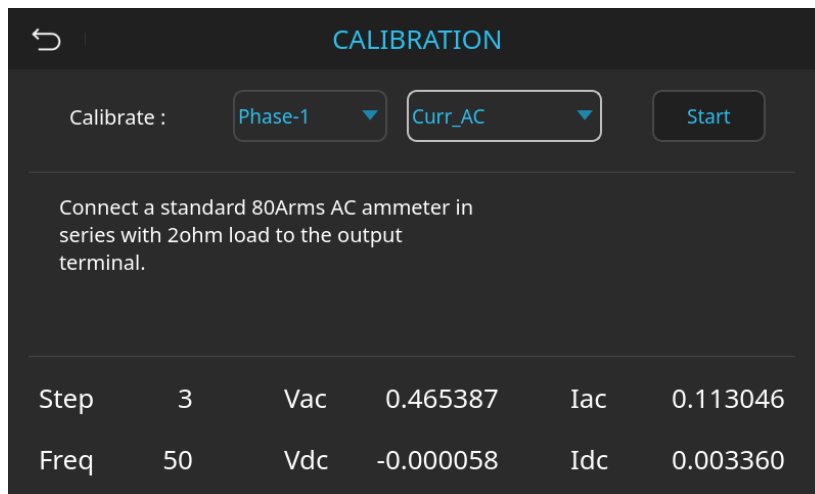



Figure 8-20 Output AC Current Calibration Screen for Phase 1

Before starting the AC output current calibration for Phase 1, a prompt will appear on the screen (as shown in Figure 8-21). Please set the ammeter to Iac mode, adjust the load connected to the output terminals to 2 ohms, and then press the  key to begin output.

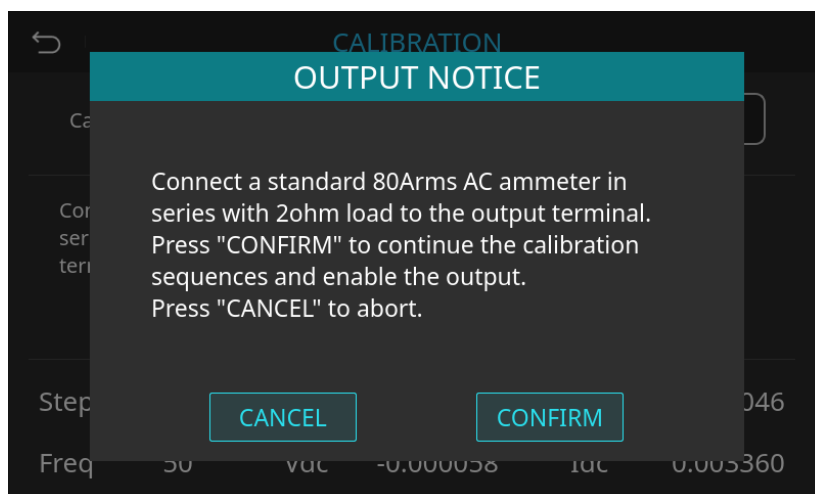

Figure 8-21 Notification Screen for AC Output Current Calibration Procedure

The user should use a Digital Current Ammeter (DCA) or a Power Analyzer to measure the AC output current (Iac) of the regenerative power system. At this stage, the output voltage is approximately 3Vac (as shown in Figure 8-22), and the reading should be taken in amperes (A). After measurement, enter the value into the DVM input field on the screen.

Next, the device will continue to output approximately 120Vac (as shown in Figure 8-23). The user should again measure the current using the DCA or Power Analyzer, and enter the measured value into the DVM input field on the screen. This will complete the AC output current calibration procedure, as shown in Figure 8-10.

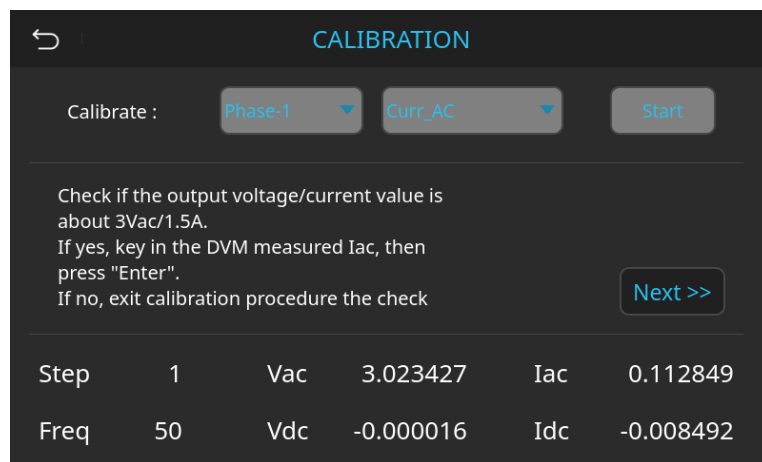

Figure 8-22 AC Output Current Calibration Procedure – Output at 3Vac

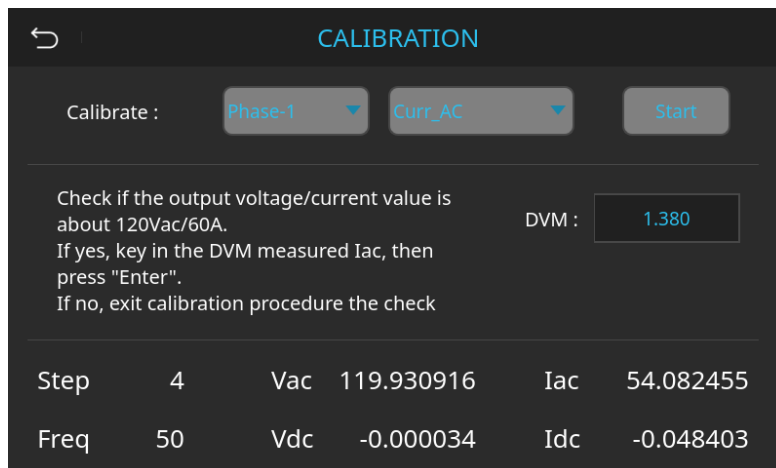



Figure 8-23 AC Output Current Calibration Procedure – Output at 120Vac

CAUTION

- During the calibration procedure, applying an improper load may trigger the protection mechanism of the regenerative power system.

After completing the calibration for Phase-1, please return to the Calibration Procedure Main Screen and follow the steps outlined in Sections 8.2.1 and 8.2.2 to perform voltage and current calibration for Phase-2 and Phase-3 in sequence. For each phase, ensure that the measured values entered match the values displayed on the device. Adjust the output as needed to achieve accurate calibration results.

Once all phases are calibrated, return to the Calibration Procedure Main Screen. The user can tap the  icon on the screen and then press the **CONFIRM** key (as shown in Figure 8-24). The system will save the calibration values and automatically return to the System Function Settings page, thereby completing the full system calibration process.

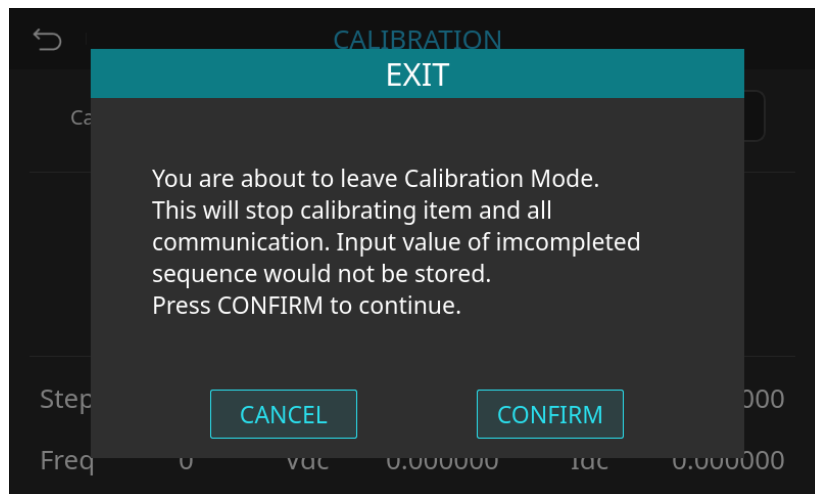

Figure 8-24 Notification Screen for Exiting the Calibration Procedure

9 Regenerative Load Function Description

The regenerative power system is equipped with a power mode switching function, allowing users to flexibly switch between Source Mode and Load Mode according to practical application needs. When switched to Load Mode, the device can simulate various active or passive load characteristics while effectively feeding the absorbed energy back to the grid. This not only saves energy but also reduces heat generation, thereby further improving overall energy efficiency.

This chapter describes the operating functions and application features supported by the instrument in Load Mode.

NOTICE

This chapter describes the operating functions and application features supported by the instrument in Load Mode.

9.1 Main Screen Overview

When the user powers on the RPS-5000 series regenerative power system and the self-diagnostic procedure is completed, if switched to Load Mode, the system will display the default main screen. As shown in Figure 9-1, this screen provides an overview of the key functional areas under Load Mode.

■ Description of the Main Screen in Standby Mode







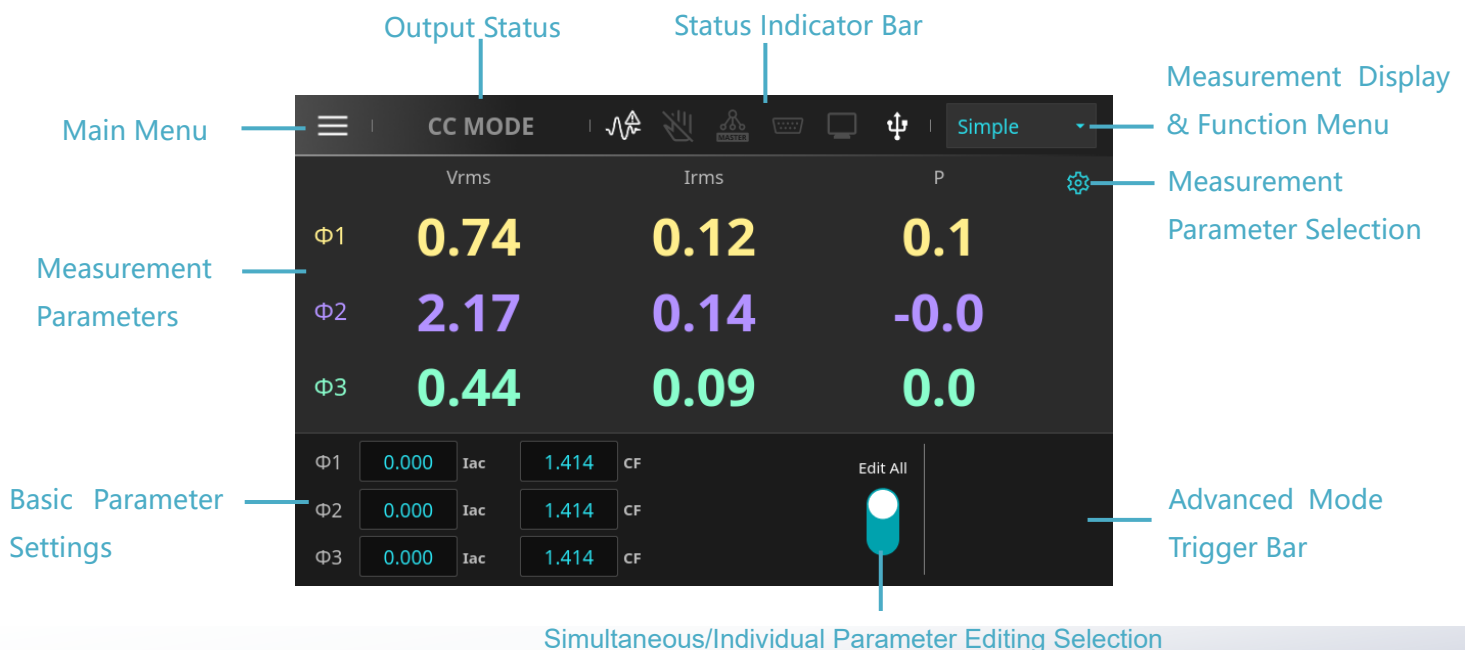

图 9-1 三相模式待机主画面(Simple 模式页面)

■ Status Indicator Bar Description

Icon	Description
	When the input voltage or frequency of the DUT (Device Under Test) is abnormal, this icon with a white border will light up.
	When the front panel lock function is enabled, the touch operation of the front panel screen will be disabled, and this icon with a white border will light up.
	When the Parallel Control function is enabled, indicating the device is operating in multi-unit parallel mode, this icon with a white border will light up.
	When the External Output ON/OFF function is enabled, the ON/OFF key on the front panel will be disabled. Output control must be performed via pin 18 of the External Interface, and this icon with a white border will light up.
	When the device is operating in remote control mode, this icon with a white border will light up.
	When a USB (Host) flash drive is inserted into the front panel and successfully recognized by the system, this icon with a white border will light up.



9.2 Main Screen Operation

9.2.1 Parameter Setting and Test Execution

The RPS-5000 series regenerative AC load equipment provides a flexible and intuitive setup method through the touch screen and rotary knob interface. Users can adjust parameters via touch selection, sliding, or rotary knob operations.

This device supports programmable settings for parameters such as AC current (Iac), Crest Factor (CF), and Power Factor (PF). These values can be set within the rated range according to actual requirements. Before executing a test, please connect the output terminals directly to the Device Under Test (DUT) and complete the necessary safety checks.

After completing the basic parameter settings on the main screen (see Figure 9-1), press the Output

(ON/OFF)  key on the front panel. The indicator light around the key will illuminate, showing that the system has entered load mode with regenerative operation, while the measurement screen will display the measured data in real time. If you need to stop the test, press the Output (ON/OFF)  key again. The indicator light will turn off, the system will stop load operation and shut down the output, and the measured values will return to zero.

Output Setting Parameter Definitions:

Parameter	Description
I _{ac}	AC current setting, unit: Ampere (A)
CF	Crest Factor setting
PF	Power Factor setting
P	Active Power setting, unit: Watt (W)
S	Apparent Power setting, unit: Volt-Ampere (VA)
R	Resistance setting, unit: Ohm (Ω)
L	Inductance setting, unit: millihenry (mH)
C	Capacitance setting, unit: microfarad (μF)
Degree	Phase Angle setting, unit: degree ($^{\circ}$)
Lead/Lag	Leading (capacitive load) or lagging (inductive load) setting

WARNING

- The Output ON/OFF key is used to activate or stop the device output. This key remains effective even under remote-control operation or when the touch screen is locked.
- When the indicator light of the Output ON/OFF key is off, the device output is in the OFF state. However, this does not guarantee that the output terminals are free of hazardous voltage. Dangerous voltage may still exist at the output terminals, posing a potential safety risk. Before connecting the DUT for testing, please read Section 3.4 Safety Precautions for Output Connections carefully.

9.3 Advanced Mode Settings

The regenerative load function integrates multiple programmable advanced operating modes to meet complex testing requirements under different application scenarios. Users can configure test conditions according to practical needs, flexibly switch load characteristics, and emulate diversified power environments. This ensures that the DUT maintains performance stability and reliability even under varying operating conditions.

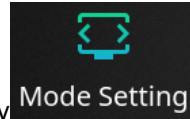

On the main menu function page, click the Mode Setting key to enter the advanced mode configuration (see Figure 9-2). The available modes include Constant Current Mode (CC Mode), Constant Power Mode (CP Mode), Constant Apparent Power Mode (CS Mode), Constant Resistance Mode (CR Mode), Load Impedance Simulation Mode (CZ Mode), Constant Current Phase Mode (CCPH Mode), and Constant Power Phase Mode (CSPH Mode).

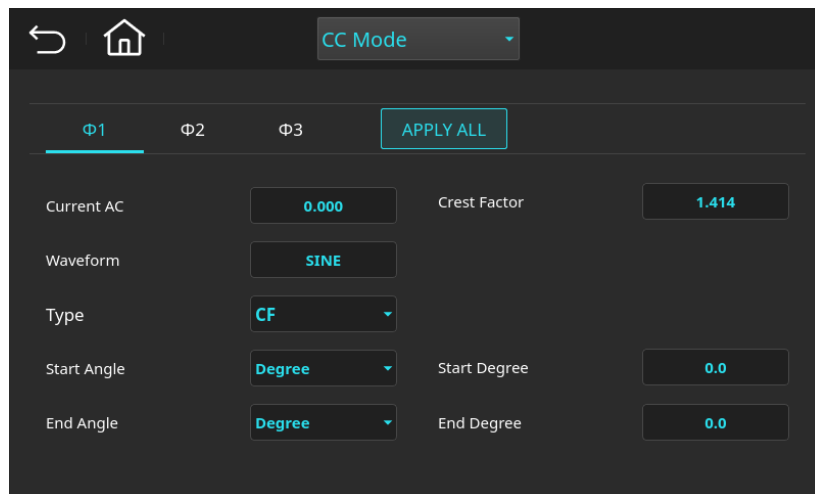

Figure 9-2 Advanced Mode Setting (Mode Setting) Page

Advanced Mode (Mode Setting) Parameter Description:

Parameter	Subsection Reference	Description
CC Mode	See Section 9.3.1	Constant Current Mode
CP Mode	See Section 9.3.2	Constant Power Mode
CS Mode	See Section 9.3.3	Constant Apparent Power Mode
CR Mode	See Section 9.3.4	Constant Resistance Mode
CZ Mode	See Section 9.3.5	Load Impedance Simulation Mode

CCPH Mode	See Section 9.3.6	Constant Current Phase Mode
CPPH Mode	See Section 9.3.7	Constant Power Phase Mode
CSPH Mode	See Section 9.3.8	Constant Apparent Power Phase Mode

9.3.1 Constant Current Mode (CC Mode)

In Constant Current Mode, the regenerative AC electronic load maintains the user-defined current value, regardless of changes in the input voltage. This mode is commonly used to verify the current supply capability of AC power sources, inverters, or UPS systems. It can also be combined with parameters such as Power Factor (PF) and Crest Factor (CF) to simulate different types of load characteristics.

On the Advanced Mode Setting page (see Figure 9-2), click the dropdown menu and select CC Mode

CC Mode to enter Constant Current Mode.

Parameter Description for CC-Mode:

Parameter	Sub-item	Description
$\Phi 1 / \Phi 2 / \Phi 3$		Phase selection settings in operation mode ($\Phi 1 / \Phi 2 / \Phi 3$)
APPLY ALL		Applies the selected phase parameter settings to all phases
Current AC	0.0 ~ 100.0 A	AC current setting value
Crest Factor	1.414 ~ 3.000	Crest Factor setting
Waveform	<ul style="list-style-type: none"> ■ SINE ■ Positive ■ Negative ■ Leading ■ Trailing 	Load waveform selection
Type	<ul style="list-style-type: none"> ■ CF ■ PF ■ CF>PF ■ PF>CF ■ Unit PF 	Current waveform and power factor parameter setting
Start Angle	<ul style="list-style-type: none"> ■ Degree ■ Immediate 	Degree : Sets the starting angle of the current waveform Immediate : Outputs the current waveform immediately at any angle
Start Degree	0.0 ~ 359.9 deg	Sets the starting angle of the current waveform
End Angle	<ul style="list-style-type: none"> ■ Degree ■ Immediate 	Degree : Sets the ending angle of the current waveform Immediate : Ends the current waveform output immediately at any angle
End Degree	0.0 ~ 359.9 deg	Sets the ending angle of the current waveform

9.3.2 Constant Power Mode(CP Mode)

In Constant Power Mode, the electronic load absorbs power according to the user-defined power value, automatically adjusting the current to maintain constant power regardless of changes in the input voltage. The load instantly compensates to ensure that the actual absorbed power remains equal to the set value. This mode is commonly used to simulate constant power loads such as servers, motor drives, power converters, and inverters. It can also be applied to test the capability of a power source to regulate voltage under constant power consumption, as well as its stability and transient response performance.

On the Advanced Mode Setting page, click the dropdown menu and select CP Mode



to enter Constant Power Mode (see Figure 9-3).

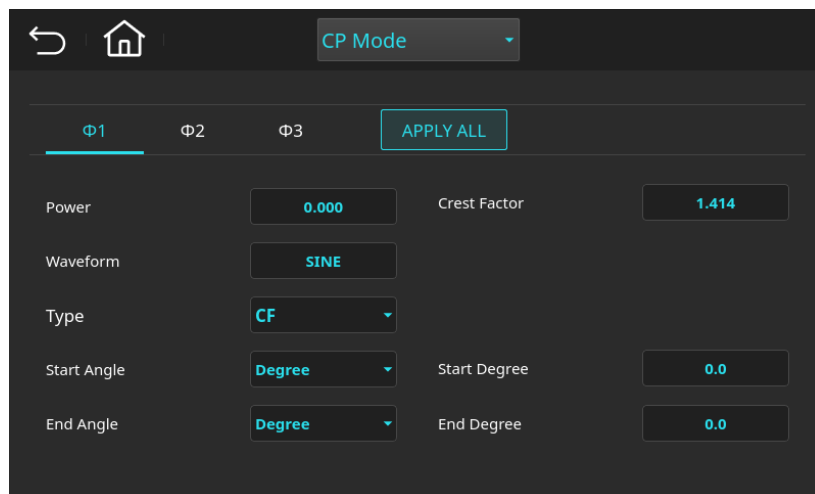

Figure 9-3 Constant Power Mode (CP-Mode) Page

Constant Power Mode (CP-Mode) Parameter Description:

Parameter	Sub-item	Description
Φ1 / Φ2 / Φ3		Phase selection settings in operation mode (Φ1 / Φ2 / Φ3)
APPLY ALL		Applies the selected phase parameter settings to all phases
Power	0.0 ~ 15000.0 W	Constant power setting value
Crest Factor	1.414 ~ 3.000	Crest Factor setting
Waveform	<ul style="list-style-type: none"> ■ SINE ■ Positive ■ Negative 	Load waveform selection

	<ul style="list-style-type: none"> ■ Leading ■ Trailing 	
Type	<ul style="list-style-type: none"> ■ CF ■ PF ■ CF>PF ■ PF>CF ■ Unit PF 	Sets the current waveform and power factor parameters
Start Angle	<ul style="list-style-type: none"> ■ Degree ■ Immediate 	Degree : Sets the starting angle of the current waveform Immediate : Outputs the current waveform immediately at any angle
Start Degree	0.0 ~ 359.9 deg	Sets the starting angle of the current waveform
End Angle	<ul style="list-style-type: none"> ■ Degree ■ Immediate 	Degree : Sets the ending angle of the current waveform Immediate : Ends the current waveform immediately at any angle
End Degree	0.0 ~ 359.9 deg	Sets the ending angle of the current waveform

9.3.3 Constant Apparent Power Mode(CS Mode)

In Constant Apparent Power Mode, the electronic load absorbs power based on the user-defined apparent power value ($S = V \times I$) and automatically adjusts the current magnitude to maintain a constant apparent power level. This mode is typically used to simulate grid-type loads that require a constant apparent power consumption, such as servers, motor drives, inverters, UPS systems, or renewable energy equipment. It also helps evaluate a power source's capability to regulate voltage under constant apparent power conditions, as well as its stability and dynamic response.

On the Advanced Mode Setting page, click the dropdown menu and select CS Mode  to enter Constant Apparent Power Mode (see Figure 9-4).

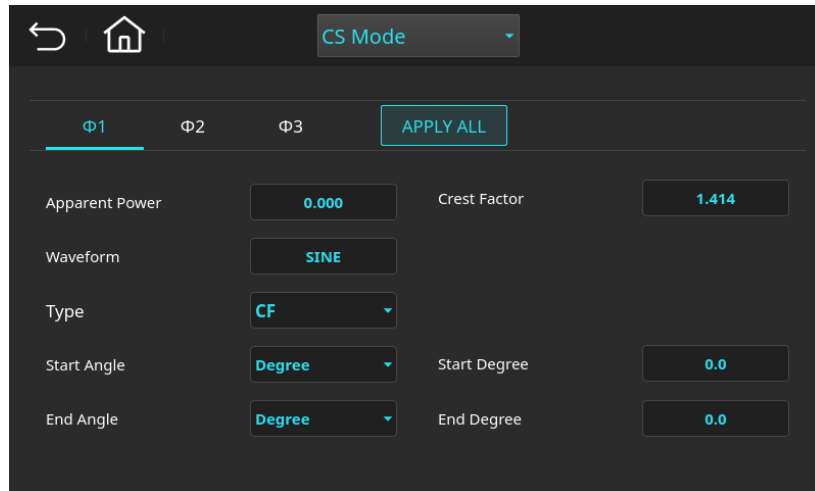



Figure 9-4 Constant Apparent Power Mode (CS-Mode) Page

CS Mode Parameter Description:

Parameter	Sub-item	Description
Φ1 / Φ2 / Φ3		Phase selection settings in operation mode (Φ1 / Φ2 / Φ3)
APPLY ALL		Applies the selected phase parameter settings to all phases
Apparent Power	0.0 ~ 15000.0 VA	Apparent power setting value
Crest Factor	1.414 ~ 3.000	Crest Factor setting
Waveform	<ul style="list-style-type: none"> ■ SINE ■ Positive ■ Negative ■ Leading ■ Trailing 	Load waveform selection
Type	<ul style="list-style-type: none"> ■ CF ■ PF ■ CF>PF ■ PF>CF ■ Unit PF 	Current waveform and power factor parameter setting
Start Angle	<ul style="list-style-type: none"> ■ Degree ■ Immediate 	Degree : Sets the starting angle of the current waveform Immediate : Outputs the current waveform immediately at any angle
Start Degree	0.0 ~ 359.9 deg	Sets the starting angle of the current waveform
End Angle	<ul style="list-style-type: none"> ■ Degree ■ Immediate 	Degree : Sets the ending angle of the current waveform Immediate : Ends the current waveform immediately at any angle
End Degree	0.0 ~ 359.9 deg	Sets the ending angle of the current waveform

9.3.4 Constant Resistance Mode(CR Mode)

In Constant Resistance Mode, the electronic load absorbs current according to the user-defined resistance value, automatically adjusting the current magnitude to maintain a constant voltage-to-current ratio. Regardless of input voltage variations, the load instantly compensates to ensure actual performance matches the theoretical resistance characteristic. This mode is commonly used to simulate purely resistive loads such as heaters, incandescent lamps, or general resistor components. It can also be applied to evaluate a power source's capability to regulate voltage under resistive load conditions, as well as its stability and dynamic response performance.

On the Advanced Mode Setting page, click the dropdown menu and select CR Mode  to enter Constant Resistance Mode (see Figure 9-5).

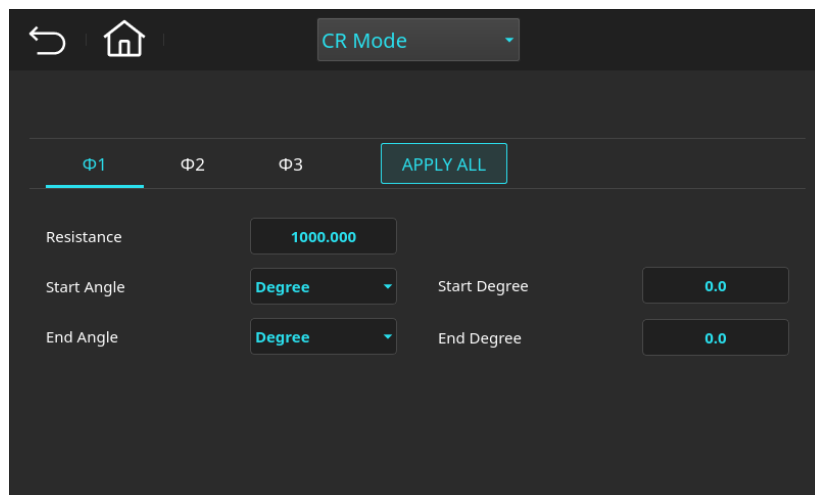

Figure 9-5 Constant Resistance Mode (CR-Mode) Page

Constant Resistance Mode (CR-Mode) Parameter Description:

Parameter	Sub-item	Description
Φ1 / Φ2 / Φ3		Phase selection settings in operation mode (Φ1 / Φ2 / Φ3)
APPLY ALL		Applies the selected phase parameter settings to all phases
Resistance	0.500 ~ 1000.000 Ω	Resistance setting value
Start Angle	<ul style="list-style-type: none"> ■ Degree ■ Immediate 	Degree : Sets the starting angle of the current waveform Immediate : Outputs the current waveform immediately at any angle
Start Degree	0.0 ~ 359.9 deg	Sets the starting angle of the current waveform

End Angle	<ul style="list-style-type: none"> ■ Degree ■ Immediate 	Degree : Sets the ending angle of the current waveform Immediate : Ends the current waveform immediately at any angle
End Degree	0.0 ~ 359.9 deg	Sets the ending angle of the current waveform

9.3.5 Load Impedance Simulation Mode(CZ Mode)

In Load Impedance Simulation Mode, the electronic load absorbs current according to the user-defined impedance value (Z) and automatically adjusts the absorbed current, so that the load exhibits a fixed impedance characteristic. Regardless of input voltage variations, the load maintains the set current-to-voltage ratio defined by the impedance. This mode is commonly used to simulate real impedance loads, such as evaluating the impact of load impedance on a power source or matching the impedance characteristics of real circuits.

On the Advanced Mode Setting page, click the dropdown menu and select CZ Mode

CZ Mode to enter Load Impedance Simulation Mode (see Figure 9-6).

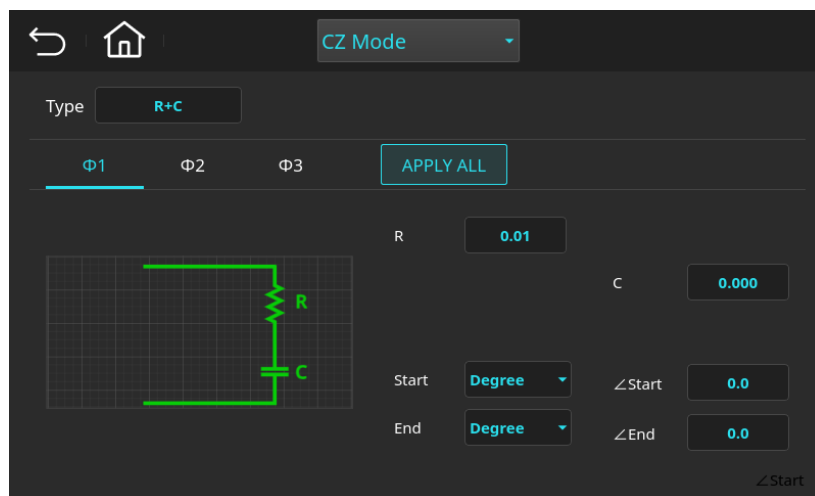

Figure 9-6 Load Impedance Simulation Operating Mode (CZ Mode) Page

Load Impedance Simulation Mode (CZ Mode) Parameter Description:

Parameter	Sub-item	Description
Type	<ul style="list-style-type: none"> ■ R+L ■ R+C ■ R+L+C ■ R // (R+L) ■ R // (R+C) ■ R // (R+L+C) ■ R+L // C 	Supported load impedance types

	<ul style="list-style-type: none"> ■ C+ R // L ■ L+R // C ■ (R+L) // (R+C) ■ R // (R+L) // (R+C) ■ R+L+(R // C) 	
Φ1 / Φ2 / Φ3		Phase selection settings in operation mode (Φ1 / Φ2 / Φ3)
APPLY ALL		Applies the selected phase parameter settings to all phases
R	0.01 ~ 1000.000 Ω	Resistance (R) setting value
R1	0.01 ~ 1000.000 Ω	Resistance (R1) setting value
R2	0.01 ~ 1000.000 Ω	Resistance (R2) setting value
R3	0.01 ~ 1000.000 Ω	Resistance (R3) setting value
L	0.000 ~ 1000.000mH	Inductance (L) setting value
C	0.000 ~ 1000.000mF	Capacitance (C) setting value
Start	<ul style="list-style-type: none"> ■ Degree ■ Immediate 	Degree : Sets the starting angle of the current waveform Immediate : Outputs the current waveform immediately at any angle
∠Start	0.0 ~ 359.9 deg	Sets the starting angle of the current waveform
End	<ul style="list-style-type: none"> ■ Degree ■ Immediate 	Degree : Sets the ending angle of the current waveform Immediate : Ends the current waveform immediately at any angle
∠End	0.0 ~ 359.9 deg	Sets the ending angle of the current waveform

9.3.6 Constant Current Phase Mode (CCPH Mode)

Constant Current Phase Mode allows users to set the phase shift (Shift Degree) of the output current relative to the voltage, in order to simulate different power factor and load phase conditions. The phase range is controlled via Phase Limit:

- Enable: Limits the phase shift to -90° to 90° , suitable for general load phase shift simulations.
- Disable: Expands the phase shift range to -180° to 180° , supporting reverse current operation. This mode can be used to test a power source's ability to absorb or recover energy in reverse current conditions.

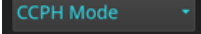
On the Advanced Mode Setting page, click the dropdown menu and select CCPH Mode  to enter Constant Current Phase Mode (see Figure 9-7).

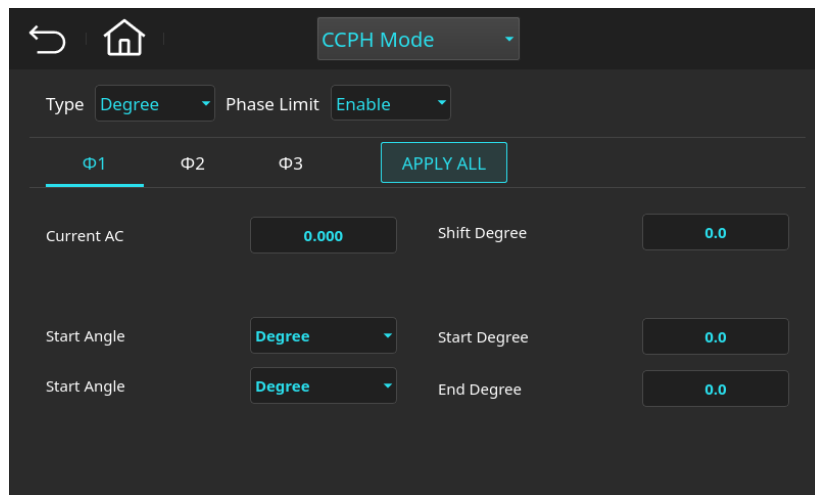

Figure 9-7 Constant Current Phase Mode (CCPH-Mode) Page

Constant Current Phase Mode (CCPH-Mode) Parameter Description:

Parameter	Sub-item	Description
Type	<ul style="list-style-type: none"> ■ Degree ■ PF 	Phase setting type Degree: Sets the phase angle of current relative to voltage PF: Sets the power factor between current and voltage
Phase Limit	<ul style="list-style-type: none"> ■ Disable ■ Enable 	Phase limit function
Φ1 / Φ2 / Φ3		Phase selection settings in operation mode (Φ1 / Φ2 / Φ3)
APPLY ALL		Applies the selected phase parameter settings to all phases
Current AC	0.0 ~ 100.0 A	AC current setting value
Shift Degree	Phase Limit = Enable <ul style="list-style-type: none"> ■ $-90.0 \sim 90.0$ deg Phase Limit = Disable	Sets the phase shift angle of current relative to voltage

	<ul style="list-style-type: none"> ■ -180.0 ~ 180.0 deg 	
Power Factor	0.100 ~ 1.000	Power factor setting value
Lead / Lag	<ul style="list-style-type: none"> ■ Lead ■ Lag 	Selects whether the power factor is leading or lagging
Start Angle	<ul style="list-style-type: none"> ■ Degree ■ Immediate 	Degree: Sets the starting angle of the current waveform Immediate: Outputs the current waveform immediately at any angle
Start Degree	0.0 ~ 359.9 deg	Sets the starting angle of the current waveform
End Angle	<ul style="list-style-type: none"> ■ Degree ■ Immediate 	Degree: Sets the ending angle of the current waveform Immediate: Ends the current waveform immediately at any angle
End Degree	0.0 ~ 359.9 deg	Sets the ending angle of the current waveform

9.3.7 Constant Power Phase Mode (CPPH Mode)

Constant Power Phase Mode allows users to set the phase shift of the output current relative to the voltage (Phase Shift) on the basis of Constant Power (CP) Mode operation. While the load absorbs a fixed constant power, it can also simulate different power factor conditions. By configuring the Phase-Limit parameter, the phase shift range can be restricted or expanded, enabling simulation of inductive (Lagging) or capacitive (Leading) load characteristics. This mode is particularly suitable for accurately reproducing non-ideal load conditions that AC power sources may encounter in real-world applications.

On the Advanced Mode Setting page, click the dropdown menu and select CPPH Mode

CPPH Mode ▾

to enter Constant Power Phase Mode (see Figure 9-8).

The screenshot shows the configuration interface for CPPH Mode. At the top, the mode is selected as 'CPPH Mode'. Below this, there are two dropdown menus: 'Type' set to 'Degree' and 'Phase Limit' set to 'Enable'. There are three phase tabs: $\Phi 1$, $\Phi 2$, and $\Phi 3$, with $\Phi 1$ selected. An 'APPLY ALL' button is located to the right of the tabs. The configuration parameters are as follows:

Power	0.000	Shift Degree	0.0
Start Angle	Degree	Start Degree	0.0
End Angle	Degree	End Degree	0.0

图 9-8 定功率相位移模式(CPPH Mode)页面

Constant Power Phase Mode (CPPH-Mode) Parameter Description:

Parameter	Sub-item	Description
Type	<ul style="list-style-type: none"> ■ Degree ■ PF 	Phase setting type Degree: Sets the phase angle of current relative to voltage PF: Sets the power factor between current and voltage
Phase Limit	<ul style="list-style-type: none"> ■ Disable ■ Enable 	Phase limit function
$\Phi 1 / \Phi 2 / \Phi 3$		Phase selection settings in operation mode ($\Phi 1 / \Phi 2 / \Phi 3$)
APPLY ALL		Applies the selected phase parameter settings to all phases
Power	0.0 ~ 15000.0 W	Constant power setting value
Shift Degree	Phase Limit = Enable <ul style="list-style-type: none"> ■ -90.0 ~ 90.0 deg Phase Limit = Disable <ul style="list-style-type: none"> ■ -180.0 ~ 180.0 deg 	Sets the current-to-voltage phase shift angle
Power Factor	0.100 ~ 1.000	Power factor setting value
Lead / Lag	<ul style="list-style-type: none"> ■ Lead ■ Lag 	Sets whether the power factor is leading or lagging
Start Angle	<ul style="list-style-type: none"> ■ Degree ■ Immediate 	Degree: Sets the starting angle of the current waveform Immediate: Outputs the current waveform immediately at any angle
Start Degree	0.0 ~ 359.9 deg	Sets the starting angle of the current waveform
End Angle	<ul style="list-style-type: none"> ■ Degree ■ Immediate 	Degree: Sets the ending angle of the current waveform Immediate: Ends the current waveform immediately at any angle
End Degree	0.0 ~ 359.9 deg	Sets the ending angle of the current waveform

9.3.8 Constant Apparent Power Phase Mode (CSPH Mode)

In Constant Apparent Power Phase Mode, the load operates on the basis of a constant apparent power value. By combining fixed apparent power with phase shift control, the mode can simulate purely inductive or purely capacitive load characteristics. It supports Lead / Lag phase conditions and is suitable for evaluating the performance and verification of power supplies, inverters, and grid-connected equipment under different power factor conditions.

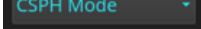
On the Advanced Mode Setting page, click the dropdown menu and select CSPH Mode  to enter Constant Apparent Power Phase Mode (see Figure 9-9).

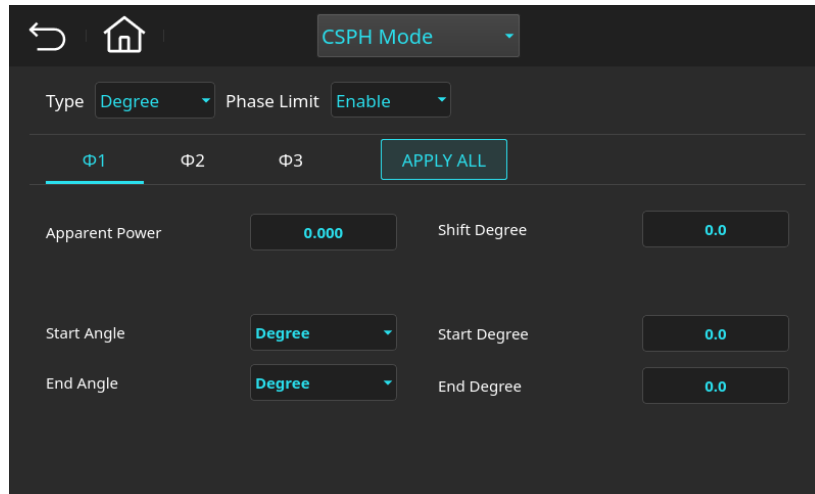

Figure 9-9 Constant Apparent Power Phase Mode (CSPH-Mode) Page

Constant Apparent Power Phase Mode (CSPH-Mode) Parameter Description:

Parameter	Sub-item	Description
Type	<ul style="list-style-type: none"> ■ Degree ■ PF 	Phase setting type Degree: Sets the phase angle of current relative to voltage PF: Sets the power factor between current and voltage
Phase Limit	<ul style="list-style-type: none"> ■ Disable ■ Enable 	Phase limit function
Φ1 / Φ2 / Φ3		Phase selection settings in operation mode (Φ1 / Φ2 / Φ3)
APPLY ALL		Applies the selected phase parameter settings to all phases
Apparent Power	0.0 ~ 15000.0 VA	Apparent power setting value
Shift Degree	Phase Limit = Enable <ul style="list-style-type: none"> ■ -90.0 ~ 90.0 deg Phase Limit = Disable <ul style="list-style-type: none"> ■ -180.0 ~ 180.0 deg 	Sets the current-to-voltage phase shift angle
Power Factor	0.100 ~ 1.000	Power factor setting value
Lead / Lag	<ul style="list-style-type: none"> ■ Lead ■ Lag 	Sets whether the power factor is leading or lagging
Start Angle	<ul style="list-style-type: none"> ■ Degree ■ Immediate 	Degree: Sets the starting angle of the current waveform Immediate: Outputs the current waveform immediately at any angle
Start Degree	0.0 ~ 359.9 deg	Sets the starting angle of the current waveform

End Angle	<ul style="list-style-type: none"> ■ Degree ■ Immediate 	Degree: Sets the ending angle of the current waveform Immediate: Ends the current waveform immediately at any angle
End Degree	0.0 ~ 359.9 deg	Sets the ending angle of the current waveform

10 Built-in Waveform Library

The RPS-5000 series power supply includes 30 built-in preset harmonic waveforms, which can operate in both AC and AC+DC modes to replace the traditional sine wave output. These waveforms are composed of specific combinations of fundamental and higher-order harmonics, allowing the simulation of various voltage distortion conditions. This functionality is especially useful for evaluating a device's tolerance to power quality variations.

Each built-in waveform includes the relative amplitude (expressed as a percentage) of each harmonic component compared to the fundamental (base) frequency, along with the phase shift of each harmonic relative to the fundamental frequency (F_0). This level of detail allows precise replication of distorted power conditions. By simulating real-world voltage distortions, the feature enhances testing efficiency for regulatory compliance, product robustness, and grid condition evaluation.

10.1 Waveform DST1

No.	Ratio %	Phase θ
5	9.80	0
7	15.80	0
8	2.16	0

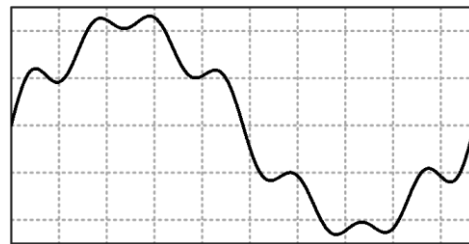

10.2 Waveform DST2

No.	Ratio %	Phase θ
3	1.50	0
7	1.50	0
19	2.00	0

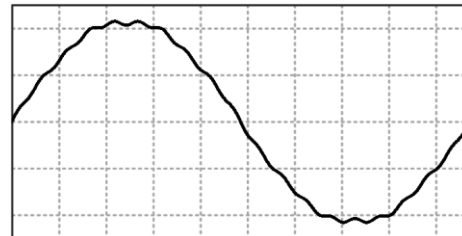

10.3 Waveform DST3

No.	Ratio %	Phase θ
3	2.00	0
5	1.40	0
7	2.00	0
23	1.40	0
31	1.00	0

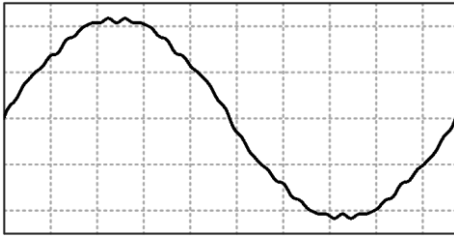

10.4 Waveform DST4

No.	Ratio %	Phase θ
3	2.50	0
5	1.90	0
7	2.50	0
23	1.90	0
25	1.10	0
31	1.50	0
33	1.10	0

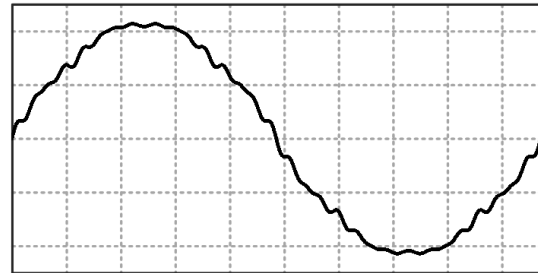

10.5 Waveform DST5

No.	Ratio %	Phase θ
3	1.10	0
5	2.80	0
7	1.40	0
9	2.30	0
11	1.50	0

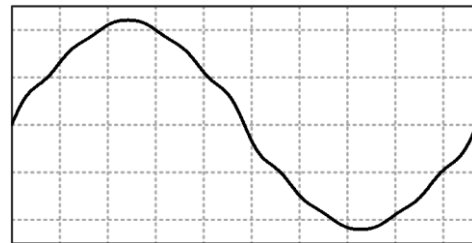

10.6 Waveform DST6

No.	Ratio %	Phase θ
3	1.65	0
5	4.20	0
7	3.45	0
15	1.05	0

19	3.00	0
----	------	---

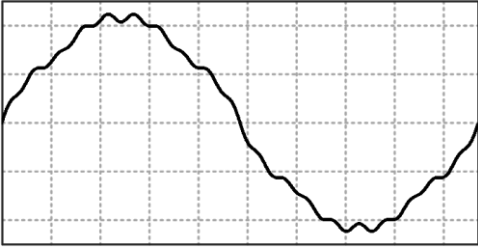

10.7 Waveform DST7

No.	Ratio %	Phase θ
3	2.20	0
5	5.60	0
7	2.80	0
9	4.60	0
11	3.00	0
15	1.40	0
21	1.00	0

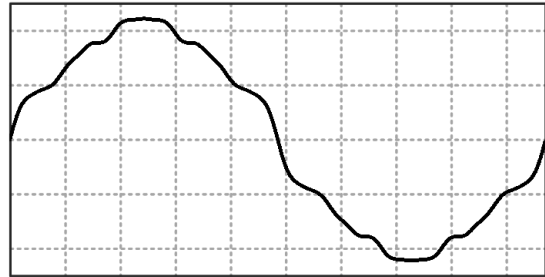

10.8 Waveform DST8

No.	Ratio %	Phase θ
3	4.90	0
5	1.60	0
7	2.70	0
11	1.40	0
15	2.00	0
17	1.10	0

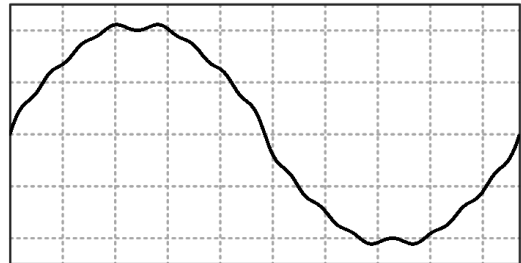

10.9 Waveform DST9

No.	Ratio %	Phase θ
-----	---------	----------------

3	7.35	0
---	------	---

5	2.40	0
7	4.05	0
11	2.10	0
13	1.05	0
15	3.00	0
17	1.65	0
19	1.05	0
21	1.05	0
23	1.20	0
25	1.05	0

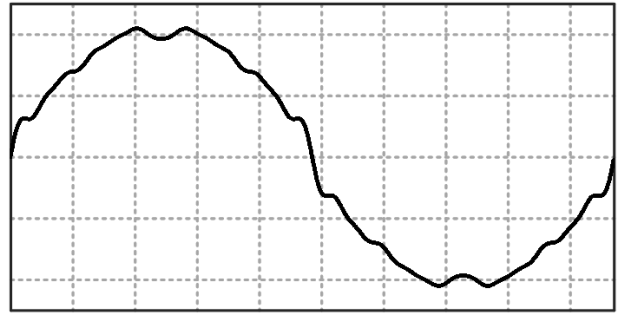

10.10 Waveform DST10

No.	Ratio %	Phase θ
3	9.80	0
5	3.20	0
7	5.40	0
9	1.20	0
11	2.80	0
13	1.40	0
15	4.00	0
17	2.20	0
19	1.40	0
21	1.40	0
23	1.60	0
25	1.40	0

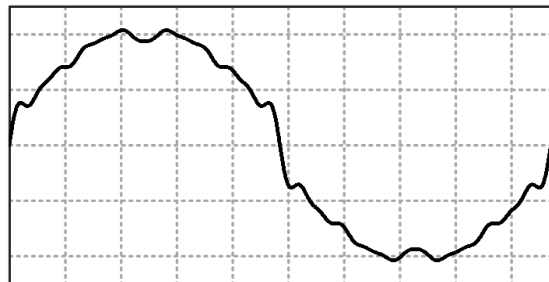

10.11 Waveform DST11

No.	Ratio %	Phase θ
3	17.75	0

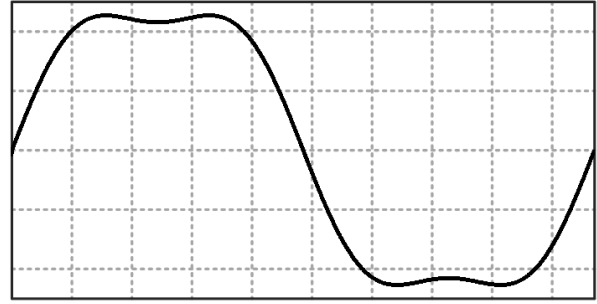

10.12 Waveform DST12

No.	Ratio %	Phase θ
3	21.25	0

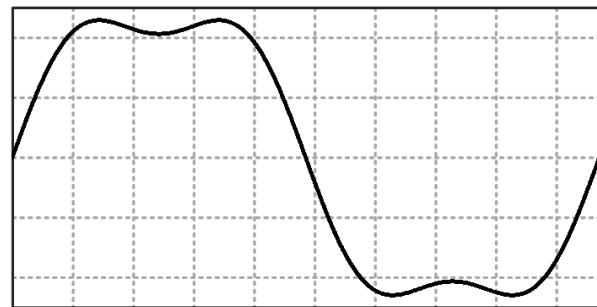

10.13 Waveform DST13

No.	Ratio %	Phase θ
3	24.50	0

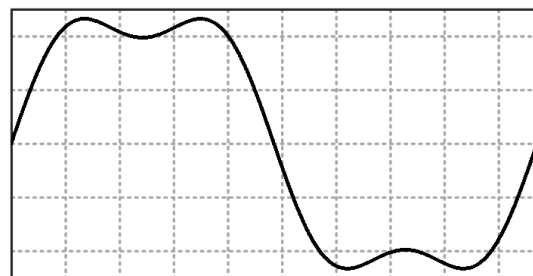

10.14 Waveform DST14

No.	Ratio %	Phase θ
2	2.30	0
5	9.80	0
7	15.80	0
8	2.50	0

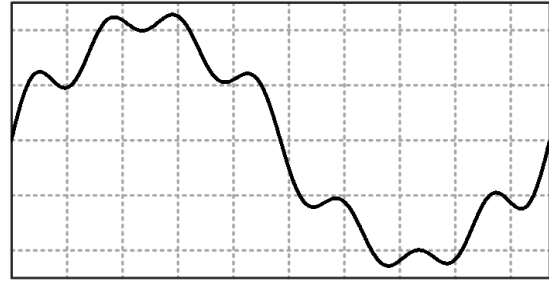

10.15 Waveform DST15

No.	Ratio %	Phase θ
2	1.15	0
5	4.90	0
7	7.90	0
8	1.25	0

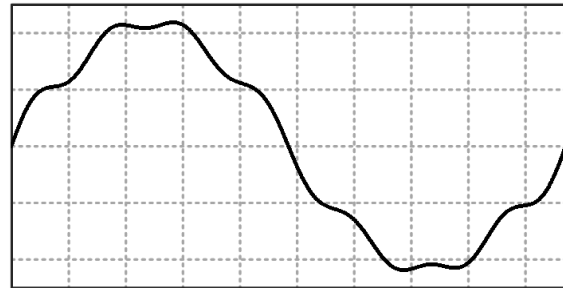

10.16 Waveform DST16

No.	Ratio %	Phase θ
5	2.45	0
7	3.95	0

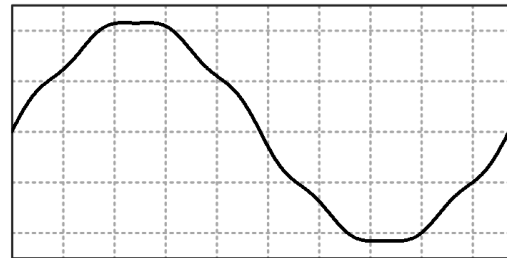

10.17 Waveform DST17

No.	Ratio %	Phase θ
3	11.11	180
5	4.00	0
7	2.04	180
9	1.23	0
11	0.83	180
13	0.59	0
15	0.44	180
17	0.35	0
19	0.28	180
21	0.23	0
23	0.19	180
25	0.16	0
27	0.14	180

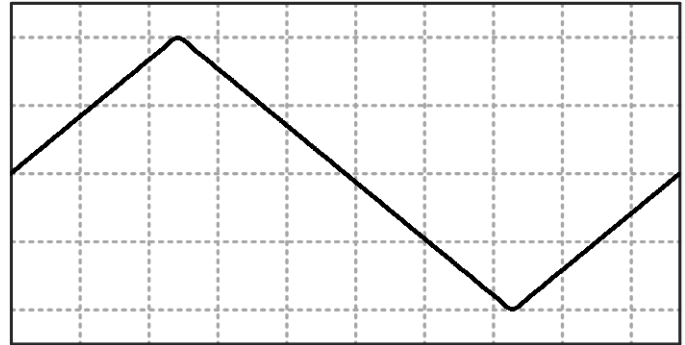

10.18 Waveform DST18

No.	Ratio %	Phase θ
3	7.17	0
5	3.42	180
9	0.80	0

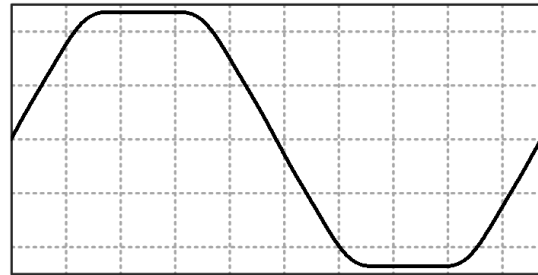

10.19 Waveform DST19

No.	Ratio %	Phase θ
3	8.07	0
5	3.55	180
9	0.96	0
13	0.92	180

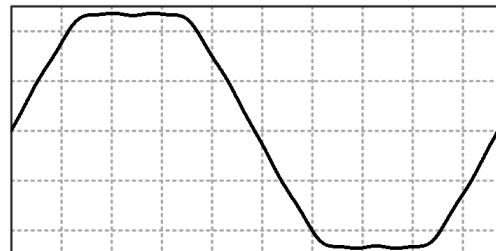

10.20 Waveform DST20

No.	Ratio %	Phase θ
3	9.38	0
5	3.44	180
9	1.12	0
13	0.50	180

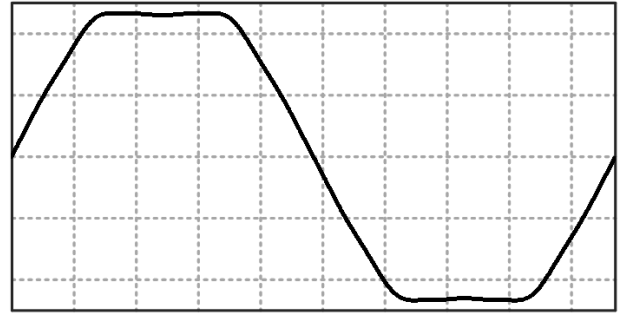

10.21 Waveform DST21

No.	Ratio %	Phase θ
3	2.06	180
5	1.77	0
7	1.62	180
9	1.23	0
11	0.91	180
13	0.54	0
23	0.51	0
25	0.53	180

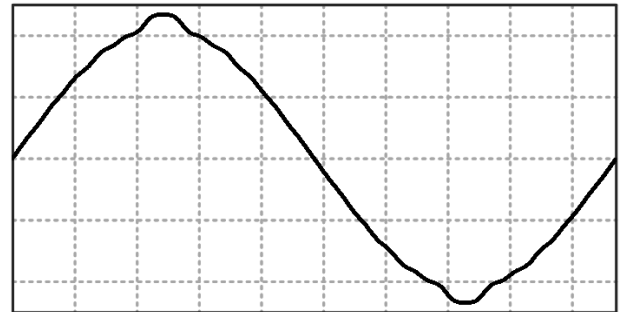

10.22 Waveform DST22

No.	Ratio %	Phase θ	No.	Ratio %	Phase θ
3	3.08	180	29	0.56	180
5	2.72	0			
7	2.43	180			
9	1.97	0			
11	1.41	180			
13	0.86	0			
21	0.62	180			
23	0.73	0			
25	0.77	180			
27	0.69	0			

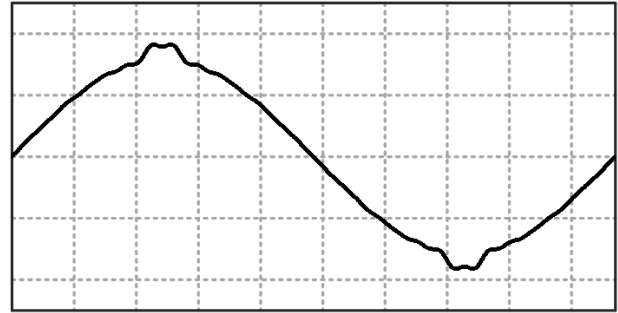

10.23 Waveform DST23

No.	Ratio %	Phase θ	No.	Ratio %	Phase θ
3	4.28	180	25	1.04	180
5	3.77	0	29	0.75	180
7	3.27	180			
9	2.57	0			
11	1.93	180			
13	1.22	0			
15	0.55	180			
19	0.46	0			
21	0.83	180			
23	0.97	0			

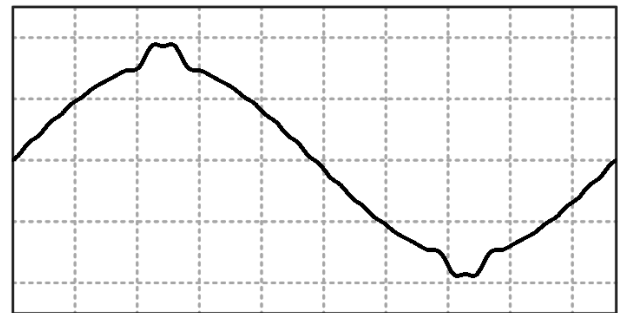

10.24 Waveform DST24

No.	Ratio %	Phase θ	No.	Ratio %	Phase θ
3	5.74	180	25	1.35	180
5	5.11	0	27	1.22	0
7	4.44	180	29	0.98	180
9	3.52	0			
11	2.63	180			
13	1.65	0			
15	0.80	180			
19	0.61	0			
21	1.07	180			
23	1.28	0			

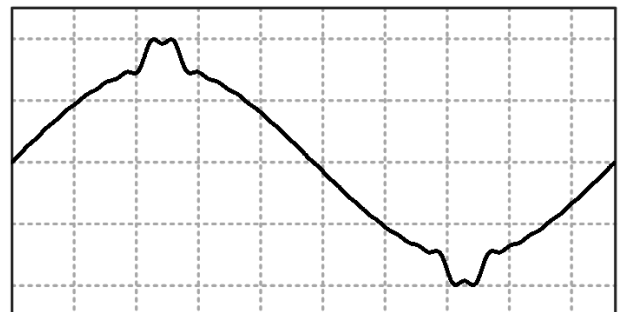

10.25 Waveform DST25

No.	Ratio %	Phase θ	No.	Ratio %	Phase θ
3	7.35	180	25	1.73	180
5	6.60	0	27	1.56	0
7	5.74	180	29	1.24	180
9	4.57	0			
11	3.41	180			
13	2.16	0			
15	1.04	180			
19	0.74	0			
21	1.35	180			
23	1.64	0			

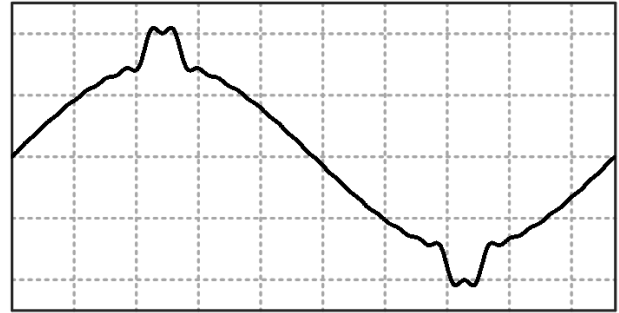

10.26 Waveform DST26

No.	Ratio %	Phase θ	No.	Ratio %	Phase θ
5	3.41	0	37	2.21	0
7	2.55	0			
11	9.22	0			
13	7.68	0			
17	0.90	0			
19	0.90	0			
23	3.88	0			
25	3.56	0			
31	0.50	0			
35	2.34	0			

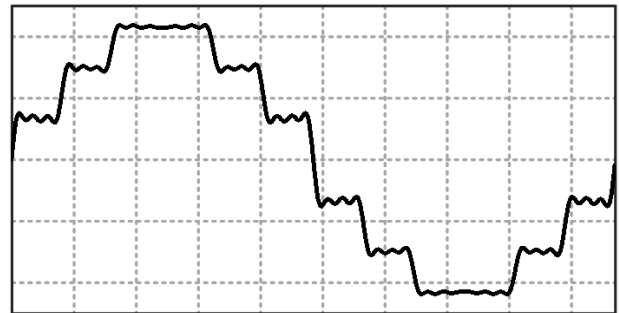

10.27 Waveform DST27

No.	Ratio %	Phase θ
21	1.24	0
23	4.91	0
25	2.21	0

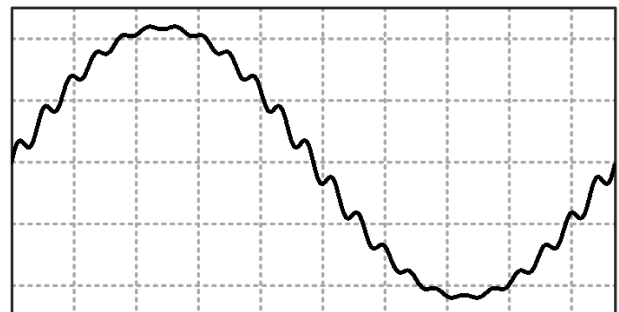

10.28 Waveform DST28

No.	Ratio %	Phase θ	No.	Ratio %	Phase θ
3	33.39	0	23	4.00	0
5	20.01	0	25	3.49	0
7	13.76	0	27	2.91	0
9	10.70	0	29	2.45	0
11	8.39	0	31	1.94	0
13	7.06	0	33	1.95	0
15	5.85	0	35	1.91	0
17	4.86	0	37	1.89	0
19	4.86	0	39	1.83	0
21	4.52	0			

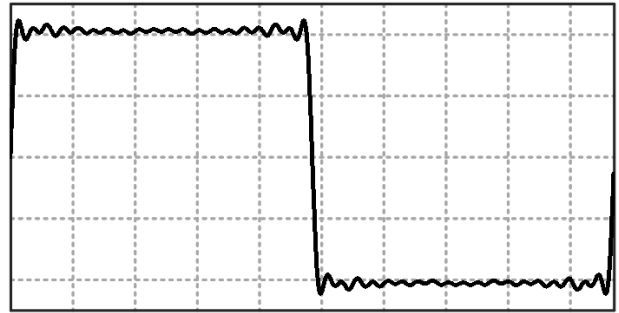

10.29 Waveform DST29

No.	Ratio %	Phase θ	No.	Ratio %	Phase θ
3	33.39	0	23	3.93	0
5	20.01	0	25	0.89	0
7	13.75	0	27	0.92	0
9	10.70	0	29	0.94	0
11	8.37	0	31	0.94	0
13	7.05	0	33	0.94	0
15	5.84	0	35	0.93	0
17	4.84	0	37	0.92	0
19	4.83	0	39	0.91	0
21	4.48	0			

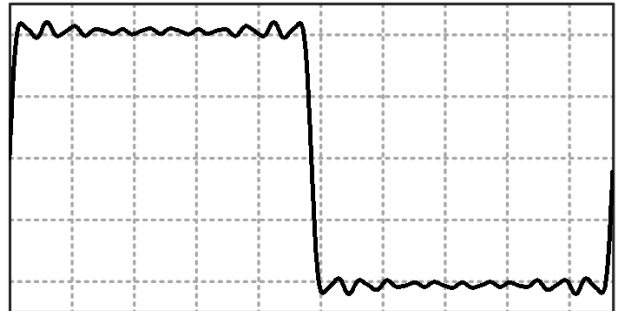

10.30 Waveform DST30

No.	Ratio %	Phase θ
3	33.39	0
5	20.01	0
7	13.75	0
9	10.70	0
11	8.33	0
13	6.99	0
15	5.26	0

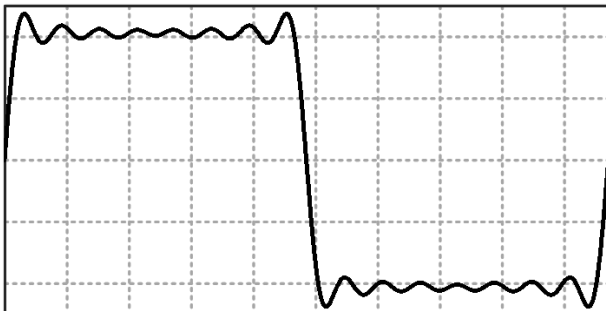

11 External I/O Pin Functions

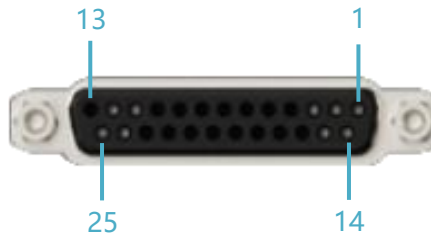

Figure 10-1 External I/O Terminal Pin Numbering Diagram

External I/O Pin Function Parameter Description:

Pin No.	Signal Name	Type	Description
1	VMON Φ 3	Output	Voltage monitor signal for Φ 3; output range: -10V to 10V.
2	VMON Φ 1	Output	Voltage monitor signal for Φ 1; output range: -10V to 10V.
3	IMON Φ 3	Output	Current monitor signal for Φ 3; output range: -10V to 10V.
4	IMON Φ 1	Output	Current monitor signal for Φ 1; output range: -10V to 10V.
5	Ext-V Φ 3	Input	Φ 3 External Voltage Reference input; input range: -10V to 10V.
6	Ext-V Φ 1	Input	Φ 1 External Voltage Reference input; input range: -10V to 10V.
7	Reserved		—
8	/ Remote-Inhibit	Input	Controls Remote Inhibit function. When the signal is LOW, output stops. Even if it returns to HIGH, output remains OFF until OUTPUT ON/OFF is pressed.
9	Reserved		
10	Reserved		
11	Reserved		
12	AC-ON	Output	Goes HIGH when system starts output; LOW when output stops.
13	/ Transient	Output	Outputs a 64 μ s LOW pulse upon output status change; otherwise remains HIGH.
14	VMON Φ 2	Output	Voltage monitor signal for Φ 2; output range: -10V to 10V.
15	AGND		Ground for V/I MON signals.
16	IMON Φ 2	Output	Current monitor signal for Φ 2; output range: -10V to 10V.
17	AGND		Ground for External Voltage Reference signals.
18	Ext-V Φ 2	Input	Φ 2 External Voltage Reference input; input range: -10V to 10V.

19	Reserved		
20	DGND		Digital I/O ground.
21	/ Ext-ONOFF	Input	External signal to control output state: HIGH = OUTPUT OFF, LOW = OUTPUT ON.
22	Reserved		—
23	DGND		Digital I/O ground.
24	/ Remote-Excite	Input	A falling edge from HIGH to LOW triggers a transient output set in advanced mode.
25	/ Fault-Out	Output	HIGH during normal operation; LOW when in protection state.

NOTICE

- In single-phase mode, when the external voltage reference input function (External V-Ref.) is enabled, the device' s voltage control reference signal is provided through the external terminal input. The corresponding control source is set to Ext-V-Φ1.

12 Remote Operation

This device supports multiple remote operation interfaces, including USB, RS-232, Ethernet, and GPIB. Users can connect to external systems through these communication ports to perform device control, parameter configuration, and data acquisition. This functionality is ideal for automated test environments, system integration, or remote monitoring operations, enhancing operational flexibility and control efficiency.

Users can access the remote communication settings by tapping the function key  on the main menu to enter the System Function Settings page (System) (see Figure 6-2). On this page, tap the

INTERFACE

option at the bottom to enter the Remote Communication Interface Settings screen, as shown in Figure 11-1.

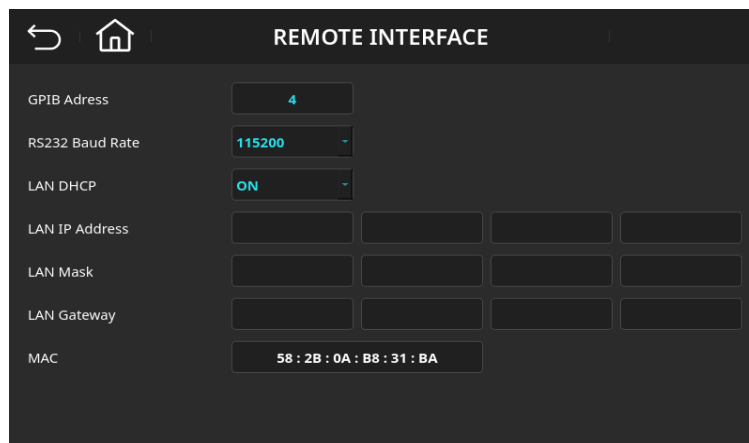

Figure 11-1 Remote Communication Interface Settings Screen

12.1 USB Interface

The RPS-5000 provides a USB interface that communicates with a computer via a virtual COM port. Before operating, please follow the steps below for installation and setup:

1. Connect the device: Plug one end of the USB cable into the USB port on the RPS-5000, and the other end into the computer's USB port.

2. Identify the COM port: After the driver is installed, open "Device Manager" and check under "Ports (COM & LPT)" for a new COM port, such as "USB Serial Port (COMn)", where n is the system-assigned port number.
3. Communication parameter settings:
 - COM Port: Select the COM port shown in Device Manager
 - Baud Rate: Supported rates (set via the front panel system settings): 9600, 19200, 38400, 115200
 - Data Bits: 8
 - Stop Bit: 1
 - Parity: NONE

12.2 RS-232 Interface

The regenerative power system has a default baud rate of 115200 for communication. The RS-232 interface uses a 9-pin D-sub male connector, with only the TxD (Transmit) and RxD (Receive) signal pins active for data transmission; the remaining pins are not used. This design ensures stable point-to-point communication, making it convenient for users to perform remote monitoring and control.

Table 11-1 RS-232 Communication Interface Pin Definitions and Functions

Pin Number	Type	Description
1	N/A	No connection
2	Input	RxD (Receive Data)
3	Output	TxD (Transmit Data)
4	N/A	No connection
5	GND	GND (Ground)
6	N/A	No connection
7	N/A	No connection
8	N/A	No connection
9	N/A	No connection

12.3 Ethernet Interface

The RPS-5000 provides an Ethernet (LAN) interface for connection to a computer or network device via the TCP/IP protocol. Follow these steps to complete the setup:

- **Connect the device:** Use a network cable to connect the LAN port of the RPS-5000 to the computer's network port or a router/switch.
- **Configure the IP address:** Set a static IP or enable DHCP based on your network environment:
 - **Static IP:** On the RPS-5000 front panel, go to system parameter settings and manually enter the IP address, subnet mask, and default gateway. For example:
 - IP Address: 192.168.0.100
 - Subnet Mask: 255.255.255.0
 - Default Gateway: 192.168.0.1
 - DHCP Mode: If your network supports automatic IP assignment, enable the DHCP function to obtain network parameters automatically.

- **Communication parameter settings:**

Host Address (IP Address): Use the IP address set on the RPS-5000, e.g., 192.168.0.100

Port Number: 5555

REMOTE INTERFACE

GPIB Address	4			
RS232 Baud Rate	115200			
LAN DHCP	ON			
LAN IP Address	192	168	60	202
LAN Mask	255	255	255	0
LAN Gateway	192	168	60	255
MAC	58 : 2B : 0A : B8 : 31 : BA			

Figure 11-2 Remote Communication Settings Screen
(DHCP Enabled for Automatic Network Parameter Acquisition)

12.4 GPIB Interface

The RPS-5000 provides an optional GPIB interface, compliant with the IEEE 488 communication protocol, for connection to computers or test equipment equipped with GPIB. Before operating, follow the steps below for connection and setup:

- **Connect the device:** Use a GPIB cable to connect the GPIB port on the RPS-5000 to the computer's GPIB controller or another test device with a GPIB port. Tighten the connector screws to ensure a secure connection and avoid contact issues.
- **Set the GPIB address:** On the RPS-5000 front panel, go to the system parameter settings and manually set the GPIB address. The valid address range is 1 to 30. Set a unique address according to your test system requirements (e.g., 5).
- **Communication verification:** Use GPIB control software (such as PowerVUE or NI MAX) to scan and detect connected devices. Ensure that the RPS-5000 appears in the scan results and displays the correct GPIB address.

NOTICE

- The configurable GPIB address range is from 1 to 30.

13 SCPI Programming Command

This chapter explains how to control the instrument using Standard Commands for Programmable Instruments (SCPI) via LAN, USB, and GPIB (optional). Before sending SCPI commands or queries, users should familiarize themselves with SCPI syntax and functions, and select the appropriate communication interface type from the front panel.

IEEE-488.2 Common Commands

The IEEE-488.2 standard defines a set of common commands for performing functions such as reset, self-test, and status queries. These commands have the following characteristics:

- They begin with an asterisk (*).
- Command length is three letters, and may include parameters.
- A space is required between the command keyword and the first parameter.

Subsystem

Subsystem commands are used to perform specific instrument functions. They follow a hierarchical structure, starting from a root node and extending one or more levels down. Related commands are grouped under a common node, forming a subsystem. For example, the following shows a partial structure tree of the OUTPut subsystem. Keywords enclosed in square brackets (e.g., [:STATe]) indicate optional elements.

OUTPut

[:STATe] ON|OFF

[:STATe]?

:PROTection

:CLEAr

Keywords

Keywords (also known as headers) are the recognizable command elements that the instrument interprets.

Common commands are also considered a type of keyword.

- OUTPut is a root-level keyword.
- STATe, MOD, and PROTection are second-level keywords.
- CLear is a third-level keyword.

A colon (:) is used to separate keyword levels in the hierarchy. The keyword syntax is case-insensitive, and both short and long forms are acceptable. For example:

- OUTP and OUTPUT are both valid.
- OUTPUT, outp and OuTp are all acceptable.
- Incorrect forms, such as OUT, will result in an error.

Query Commands (Queries)

A query is formed by adding a question mark (?) after a keyword. For example:

VOLTage?

PHASe:FUNCTion?

When a query includes a parameter, the question mark should be placed after the last keyword and before the parameter, with a space between the question mark and the first parameter. For example:

VOLTage? MIN

VOLTage? MAX

Separators

Colon (:) is used to separate keyword levels. Space is used to separate a keyword from its parameter. Comma (,) is used to separate multiple parameters. Semicolon (;) is used to separate multiple commands within the same subsystem or between different subsystems. For example:

```
[SOURce:]SYNThesis:PERCent:ORDer <order>,<value>
```

In the command SYNTHeSis:PERCent:ORDer 2,50, 2 and 50 are two parameters separated by a comma.:

Terminator

A command string must end with a newline character (<NL>), or use the IEEE-488 EOI (End-Of-Identify) signal as <NL>.

Syntax Conventions

- < > (Angle brackets): Represent parameters, e.g., CURRent <value>. Angle brackets are not included in the actual command.
- | (Vertical bar): Indicates multiple options, e.g., AC|DC|ACDC, meaning you may select AC, DC, or ACDC.
- [] (Square brackets): Denote optional elements, e.g., OUTPut[:STATe], where [:STATe] is optional.

13.1 IEEE Common Commands

According to the IEEE 488.2 standard, all SCPI-compliant instruments must implement the mandatory common commands defined in the IEEE 488.2 specification. These commands are primarily used for operations such as clearing the instrument status, configuration, and queries, and they form the core components of SCPI programming.

Command List

The table below lists all mandatory commands defined in the IEEE 488.2 standard, including the mnemonic and description:

*CLS

Clear Status Command: Clears all errors and event states, restoring the instrument to its initial condition.

*ESE

Standard Event Status Enable Command: Sets the enable bits of the standard event status register, controlling which events trigger a service request.

*ESE?

Standard Event Status Enable Command: Sets the enable bits of the standard event status register, controlling which events trigger a service request.

***ESR?**

Standard Event Status Enable Query: Queries the current enable bits of the standard event status register.

***IDN?**

Identification Query: Queries the instrument's manufacturer, model number, serial number, and firmware version for device identification.

***OPC**

Operation Complete Command: Sets the Operation Complete flag once all pending operations have finished.

***OPC?**

Operation Complete Query: Queries whether all operations are complete. Returns 1 if complete, 0 if still in progress.

***RST**

Reset Command: Resets the instrument to its default state, equivalent to initialization.

***SRE**

Service Request Enable Command: Sets the enable bits in the Service Request register to determine which conditions trigger a service request.

***SRE?**

Service Request Enable Query: Queries the current settings of the Service Request register enable bits.

***STB?**

Returns the current status byte value, showing the instrument's status and service request information.

***TST?**

Self-Test Query: Executes a self-test routine and returns the result; 0 indicates success, 1 indicates failure.

***WAI**

Wait-to-Continue Command: Prevents new command processing until all currently executing operations are complete.

13.2 INSTRUMENT Subsystem

INSTRUMENT

:MODE SOURCE|DCLOAD|ACLOAD

:MODE?

:SELECT OUTPUT1|OUTPUT2|OUTPUT3

:SELECT?

:NSELECT 1|2|3

:NSELECT?

:EDIT EACH|ALL

:EDIT?

:COUPLE NONE|ALL

:COUPLE?

:PHASE THREE|SINGLE|SPLIT

:PHASE?

INSTRUMENT Command Table

Command	Description
INSTRUMENT:MODE SOURCE DCLOAD ACLOAD INSTRUMENT:MODE?	Switch the instrument's main function: Power Mode / AC Load / DC Load
INSTRUMENT:SELECT OUTPUT1 OUTPUT2 OUTPUT3 INSTRUMENT:SELECT?	Use mnemonic to select the output phase controlled by the current command
INSTRUMENT:NSELECT 1 2 3 INSTRUMENT:NSELECT?	Use numeric value to select the output phase controlled by the current command

INSTRument:EDIT EACH ALL INSTRument: EDIT?	Toggle whether the currently controlled phase is set to all phases unified for editing and querying purposes
INSTRument:COUPlE NONE ALL INSTRument:COUPlE?	Compatible commands using different parameters of INSTRument:EDIT
INSTRument:PHASe THREE SINGLE SPLIT INSTRument:PHASe?	Switch the output phase mode of the power source: Three-phase / Single-phase / Split-phase mode

INSTRument:MODE SOURce|DCLOAD|ACLOAD**INSTRument:MODE?**

Switch the instrument's main function: Power Mode / AC Load / DC Load

Parameter	Typical Response
SOURce DCLOAD ACLOAD	SOURCE
Example:	
INST:MODE SOUR	

INSTRument:SELEct OUTPUT1|OUTPUT2|OUTPUT3**INSTRument:SELEct?**

Use a mnemonic to select the output phase controlled by the current command.

Parameter	Typical Response
OUTPUT1 OUTPUT2 OUTPUT3	OUTPUT3
Example: Select RGS5000 to control all phases	
INST:SEL OUTPUT1	

INSTRument:NSELEct 1|2|3**INSTRument:NSELEct?**

Use a numeric value to select the output phase controlled by the current command.

Parameter	Typical Response
-----------	------------------

1|2|3

3

Example: Select RGS5000 to control all phases

INST 2

INSTrument:EDIT EACH|ALL

INSTrument: EDIT?

Toggle whether the currently controlled phase is set to all phases for unified editing and querying.

Parameter	Typical Response
EACH ALL	ALL
Example:	
INST:EDIT EACH	

INSTrument:COUPlE NONE|ALL

INSTrument:COUPlE?

Toggle whether the currently controlled phase is set for unified editing and querying across all phases.

Parameter	Typical Response
NONE ALL	NONE
Example:	
INST:COUP None	

INSTrument:PHASe THREE|SINGLE|SPLIT

INSTrument:PHASe?

Switch the output phase mode of the power source: Three-phase / Single-phase / Split-phase mode

Parameter	Typical Response
THREE SINGLE SPLIT	SINGLE
Example:	
INST:PHAS THREE	

13.3 [SOURce:]VOLTage Subsystem

[SOURce:]VOLTage

[:LEVel]

[:IMMediate][:AMPLitude]

[:AC] <value>| MINimum|MAXimum|DEFault

[:AC]? [MINimum|MAXimum|DEFault]

[:AC]

:PROTection <value>| MINimum|MAXimum|DEFault

:PROTection? [MINimum|MAXimum|DEFault]

:DC <value>| MINimum|MAXimum|DEFault

:DC? [MINimum|MAXimum|DEFault]

:LIMit

:AC <value>| MINimum|MAXimum|DEFault

:AC? [MINimum|MAXimum|DEFault]

:DC

:{PLUS|UPPer} <value>| MINimum|MAXimum|DEFault

:{PLUS|UPPer}? [MINimum|MAXimum|DEFault]

: MINus <value>| MINimum|MAXimum|DEFault

: MINus? [MINimum|MAXimum|DEFault]

[SOURce:]VOLTage Command Table

Command	Description
[SOURce:]VOLTage[:LEVel][:IMMediate][:AMPLitude][:AC] <value> MINimum MAXimum DEFault	Set the real-time AC output voltage RMS value; can be queried or set to maximum/minimum/default value
[SOURce:]VOLTage[:LEVel][:IMMediate][:AMPLitude][:AC]? [MINimum MAXimum DEFault]	

[SOURce:]VOLTage[:LEVel][:IMMEDIATE][:AMPLitude][:AC]:PROTECTION <value> MINimum MAXimum DEFAULT [SOURce:]VOLTage[:LEVel][:IMMEDIATE][:AMPLitude][:AC]:PROTECTION? [MINimum MAXimum DEFAULT]	Set the output voltage over-peak protection value; can be queried or set to maximum/minimum/default value
[SOURce:]VOLTage[:LEVel][:IMMEDIATE][:AMPLitude]:DC <value> MINimum MAXimum DEFAULT [SOURce:]VOLTage[:LEVel][:IMMEDIATE][:AMPLitude]:DC? [MINimum MAXimum DEFAULT]	Set the real-time DC output voltage value; can be queried or set to maximum/minimum/default value
[SOURce:]VOLTage[:LEVel]:LIMIT:AC <value> MINimum MAXimum DEFAULT [SOURce:]VOLTage[:LEVel]:LIMIT:AC? [MINimum MAXimum DEFAULT]	Set the upper limit for AC voltage setting
[SOURce:]VOLTage[:LEVel]:LIMIT:DC:{UPPER PLUS} <value> MINimum MAXimum DEFAULT [SOURce:]VOLTage[:LEVel]:LIMIT:DC:{UPPER PLUS}? [MINimum MAXimum DEFAULT]	Set the upper limit for DC voltage setting
[SOURce:]VOLTage[:LEVel]:LIMIT:DC:MINus <value> MINimum MAXimum DEFAULT [SOURce:]VOLTage[:LEVel]:LIMIT:DC:MINus? [MINimum MAXimum DEFAULT]	Set the lower limit for DC voltage setting

[SOURce:]VOLTage[:LEVel][:IMMEDIATE][:AMPLitude][:AC] <value>|MINimum|MAXimum|DEFAULT

[SOURce:]VOLTage[:LEVel][:IMMEDIATE][:AMPLitude][:AC]? [MINimum|MAXimum|DEFAULT]

Set the real-time AC output voltage RMS value

Parameter	Typical Response
<value> MINimum MAXimum DEFAULT	100
Example: Set AC voltage to 100.0 V for all phases of RGS5000	
INST ALL	
VOLT 100.0	

[SOURce:]VOLTage[:LEVel][:IMMEDIATE][:AMPLitude][:AC]:PROTECTION

<value>|MINimum|MAXimum|DEFAULT

[SOURce:]VOLTage[:LEVel][:IMMEDIATE][:AMPLitude][:AC]:PROTECTION? [MINimum|MAXimum|DEFAULT]

Set the output voltage over-peak protection value

Parameter	Typical Response
<NR2>, valid range: 0~505.0V	30.5
Example: Set the Over Voltage Protection (OVP) value to 505A in Power Mode	
VOLT:PROT 505	

[SOURce:]VOLTage[:LEVel][:IMMediate][:AMPLitude]:DC <value>|MINimum|MAXimum|DEFault

[SOURce:]VOLTage[:LEVel][:IMMediate][:AMPLitude]:DC? <value>|MINimum|MAXimum|DEFault

Set the real-time DC output voltage value

Parameter	Typical Response
<NR2>, valid range: -495.0~495.0V	100
Example: Set DC voltage to 100.0 V for all phases of RGS5000	
INST ALL	
VOLT:DC 100.0	

[SOURce:]VOLTage[:LEVel]:LIMit:AC <value>|MINimum|MAXimum|DEFault

[SOURce:]VOLTage[:LEVel]:LIMit:AC? [MINimum|MAXimum|DEFault]

Set the upper limit for AC voltage setting

Parameter	Typical Response
<NR2>, valid range: 0~350.0V	100
Example: Set the AC voltage upper limit to 100.0 V for RGS5000	
VOLT:AC:LIM 100.0	

[SOURce:]VOLTage[:LEVel]:LIMit:DC[:PLUS] <value>|MINimum|MAXimum|DEFault

[SOURce:]VOLTage[:LEVel]:LIMit:DC[:PLUS]? [MINimum|MAXimum|DEFault]

Set the upper limit for DC voltage setting

Parameter	Typical Response
<NR2>, valid range: -495.0~495.0V	100
Example: Set the DC voltage upper limit to 100.0 V for RGS5000	
VOLT:DC:LIM 100.0	

[SOURce:]VOLTage[:LEVel]:LIMit:DC:MINus <value>|MINimum|MAXimum|DEFault

[SOURce:]VOLTage[:LEVel]:LIMit:DC:MINus? [MINimum|MAXimum|DEFault]

Set the lower limit for DC voltage setting

Parameter	Typical Response
<NR2>, valid range: -495.0~495.0V	-100
Example: Set the DC voltage lower limit to -100.0 V for RGS5000	
VOLT:DC:LIM:MIN -100.0	

13.4 [SOURce:]CURRent Subsystem

[SOURce:]CURRent

[:LEVel]

:LIMit <value>|MINimum|MAXimum|DEFault

:LIMit? [MINimum|MAXimum|DEFault]

:PROTection <value>|MINimum|MAXimum|DEFault

:PROTection? [MINimum|MAXimum|DEFault]

[:PROTection]

:DELay <value>|MINimum|MAXimum|DEFault

:DELay? [MINimum|MAXimum|DEFault]

:INRush|SURGe

:INTerval <value>|MINimum|MAXimum|DEFault

:INTerval? [MINimum|MAXimum|DEFault]

:STARt|DELay <value>|MINimum|MAXimum|DEFault

:STARt|DELay? MINimum|MAXimum|DEFault

:CONTRol DISABLE|ENABLE

:CONTRol?

:CONTRol

:VALue <value>|MINimum|MAXimum|DEFault

:VALue? [MINimum|MAXimum|DEFault]

[SOURce:]CURRent Command Table

Command	Description
[SOURce:]CURRent[:LEVel]:{LIMit PROTection} <value> MINimum MAXimum DEFault [SOURce:]CURRent[:LEVel]: {LIMit PROTection}? [MINimum MAXimum DEFault]	Set the effective value of the output overcurrent protection; can be queried or set to maximum/minimum/default value
[SOURce:]CURRent[:LEVel]:PROTection:DELaY <value> MINimum MAXimum DEFault [SOURce:]CURRent[:LEVel]:PROTection:DELaY? [MINimum MAXimum DEFault]	Set the delay time (in seconds) for output overcurrent protection detection; can be queried or set to maximum/minimum/default value
[SOURce:]CURRent[:LEVel]:{INRush SURGe}:INTerval <value> MINimum MAXimum DEFault [SOURce:]CURRent[:LEVel]:INRush SURGe:INTerval? [MINimum MAXimum DEFault]	Set the inrush current measurement detection window time (in milliseconds); can be queried or set to maximum/minimum/default value
[SOURce:]CURRent[:LEVel]:{INRush SURGe};{STARt DELaY} <value> MINimum MAXimum DEFault [SOURce:]CURRent[:LEVel]:INRush SURGe:STARt DELaY? [MINimum MAXimum DEFault]	Set the inrush current measurement start time (in milliseconds); can be queried or set to maximum/minimum/default value
[SOURce:]CURRent:CONTRol DISABLE ENABLE [SOURce:]CURRent:CONTRol?	Enable or disable the output current limit function
[SOURce:]CURRent:CONTRol:VALue <value> MINimum MAXimum DEFault [SOURce:]CURRent:CONTRol:VALue? [MINimum MAXimum DEFault]	Set the effective value of the output current limit; can be queried or set to maximum/minimum/default value

[SOURce:]CURRent[:LEVel]:{LIMit|PROTection} <value>|MINimum|MAXimum|DEFault

[SOURce:]CURRent[:LEVel]: {LIMit|PROTection}? [MINimum|MAXimum|DEFault]

Set the effective value of the output overcurrent protection

Parameter	Typical Response
-----------	------------------

In single-phase mode: <NR2>, valid range: 3.0 ~ 306.0 (A) 102

In three-phase mode: <NR2>, valid range: 1.0 ~ 102.0 (A)

Example: Set the output current upper limit value to 102 A

CURR:LIM 102

[SOURce:]CURRent[:LEVel]:PROTection:DELay <value>|MINimum|MAXimum|DEFault

[SOURce:]CURRent[:LEVel]:PROTection:DELay? [MINimum|MAXimum|DEFault]

Set the delay time (in seconds) for output overcurrent protection detection

Parameter	Typical Response
<NR2>, valid range: 0.0~5.0 (sec)	0.1
Example: Set the overcurrent protection (OCP) delay time to 0.1 sec	
CURR:PROT:DEL 0.1	

[SOURce:]CURRent[:LEVel]:{INRush|SURGe}:INTerval <value>|MINimum|MAXimum|DEFault

[SOURce:]CURRent[:LEVel]:{INRush|SURGe}:INTerval? [MINimum|MAXimum|DEFault]

Set the inrush current measurement detection window time (milliseconds)

Parameter	Typical Response
<NR1>, valid range: 0 ~9999 (msec)	100
Example: Set the inrush current measurement detection window to 100 ms	
CURR:INR:INT 100	

[SOURce:]CURRent[:LEVel]:{INRush|SURGe}:{STARt|DELay} <value>|MINimum|MAXimum|DEFault

[SOURce:]CURRent[:LEVel]:{INRush|SURGe}:{STARt|DELay}? [MINimum|MAXimum|DEFault]

Set the inrush current measurement start time (milliseconds)

Parameter	Typical Response
<NR1>, valid range: 0 ~9999 (msec)	100
Example: Set the inrush current measurement start time to	
CURR:INR:STAR 100	

[SOURce:]CURRent:CONTrol DISABLE|ENABLE

[SOURce:]CURRent:CONTrol?

Set whether the output current limit function is enabled

Parameter	Typical Response
DISABLE: Disable output current limit	ENABLE
ENABLE: Enable output current limit	
Example: Enable current limit mode	
CURR:CONT ENABLE	

[SOURce:]CURRent:CONTrol:VALue <Value>

[SOURce:]CURRent:CONTrol:VALue?

Set the effective value of the output current limit

Parameter	Typical Response
Single-phase mode: <NR2>, valid range: 3.0 ~ 306.0 (A)	50
Three-phase mode: <NR2>, valid range: 1.0 ~ 102.0 (A)	
Example: Set the output current limit value to 80 A	
CURR:CONT:VAL 80	

13.5 [SOURce:]FREQUency Subsystem

[SOURce:]FREQUency

[:{CW|IMMEDIATE}] <value>|MINimum|MAXimum|DEFault

[:{CW|IMMEDIATE}]? [MINimum|MAXimum|DEFault]

:LIMit <value>|MINimum|MAXimum|DEFault

:LIMit? [MINimum|MAXimum|DEFault]

[SOURce:]FREQUency Command Table

Command	Description
[SOURce:]FREQUency[:CW IMMEDIATE] <value> MINimum MAXimum DEFault	Set the real-time output signal frequency; can be queried or set to maximum/minimum/default value
[SOURce:]FREQUency[:CW IMMEDIATE]? [MINimum MAXimum DEFault]	

[SOURce:]FREQUency:LIMit <value> MINimum MAXimum DEFault	Set the upper limit for
[SOURce:]FREQUency:LIMit? [MINimum MAXimum DEFault]	output frequency
	setting

[SOURce:]FREQUency[:CW|IMMEDIATE] <value>|MINimum|MAXimum|DEFault

[SOURce:]FREQUency[:CW|IMMEDIATE]? [MINimum|MAXimum|DEFault]

Set the real-time output signal frequency

Parameter	Typical Response
<NR2>, valid range: 15.0 ~150.0 (Hz)	50
Example: Set the real-time output signal frequency to 50 Hz	
FREQ 50	

[SOURce:]FREQUency:LIMit <value>|MINimum|MAXimum|DEFault

[SOURce:]FREQUency:LIMit? [MINimum|MAXimum|DEFault]

Set the upper limit for output frequency setting

Parameter	Typical Response
<NR2>, valid range: 15.0 ~150.0 (Hz)	60
Example: Set the upper limit for output frequency in power mode to 60 Hz	
FREQ:LIM 60	

13.6 [SOURce:]POWer

[SOURce:]POWer

:PROTection <value>|MINimum|MAXimum

:PROTection? [MINimum|MAXimum|DEFault]

:CONTRol DISABLE|ENABLE

:CONTRol?

:CONTRol

:VALue <value>|MINimum|MAXimum|DEFault

:VALue? [MINimum|MAXimum|DEFault]

[SOURce:]FREQUency Command Table

Command	Description
[SOURce:]POWer:PROTection <value> MINimum MAXimum DEFault [SOURce:]POWer:PROTection? [MINimum MAXimum DEFault]	Set the output over power protection value; can be queried or set to maximum/minimum/default value
[SOURce:]POWer:CONTRol DISABLE ENABLE [SOURce:]POWer:CONTRol?	Set whether the output power limit function is enabled
[SOURce:]POWer:CONTRol:VALue <value> MINimum MAXimum DEFault [SOURce:]POWer:CONTRol:VALue? [MINimum MAXimum DEFault]	Set the output power limit value; can be queried or set to maximum/minimum/default value

[SOURce:]POWer:PROTection <value>|MINimum|MAXimum|DEFault

[SOURce:]POWer:PROTection? [MINimum|MAXimum|DEFault]

Set the output over power protection value

Parameter	Typical Response
Single-phase mode: <NR2>, valid range: 3.0 ~ 45900.0 (W)	15300
Three-phase mode: <NR2>, valid range: 1.0 ~ 15300.0 (W)	
Example: Set the output over power protection value = 15300 W	
POW:PROT 15300	

[SOURce:]POWer:CONTRol DISABLE|ENABLE

[SOURce:]POWer:CONTRol?

Enable or disable the output power limit function

Parameter	Typical Response
DISABLE: Disable the output power limit	DISABLE ENABLE
ENABLE: Enable the output power limit	

Example:

```
POW:CONT ENABLE
```

[SOURce:]POWER:CONTrol:VALue <value>|MINimum|MAXimum|DEFault

[SOURce:]POWER:CONTrol:VALue? [MINimum|MAXimum|DEFault]

Set the output power limit value.

Parameter	Typical Response
Single-phase mode: <NR2>, valid range: 3.0 ~ 45900.0 (W)	5000
Three-phase mode: <NR2>, valid range: 1.0 ~ 15300.0 (W)	
Example: Set the output power limit value to 5000 W	
POW:CONT:VAL 5000	

13.7 [SOURce:]FUNCTION

[SOURce:]FUNCTION

:SHAPE SINE|SQUARE|TRIANGLE|CSIN|DST<01..30>|USR<01..30>|A|B

:SHAPE?

[:CSIN]

:MODE THD|AMP

:MODE? [MINimum|MAXimum|DEFault]

:CSIN

:THD <value>|MINimum|MAXimum

:THD? [MINimum|MAXimum|DEFault]

:AMP <value>|MINimum|MAXimum

:AMP? [MINimum|MAXimum|DEFault]

:SHAPE

:A SINE|SQUARE|TRIANGLE|CSIN|DST<01..30>|USR<01..30>

:A?

```

:A

:MODE THD|AMP

:MODE?

:THD <value>|MINimum|MAXimum

:THD? [MINimum|MAXimum|DEFault]

:AMP <value>|MINimum|MAXimum

:AMP? [MINimum|MAXimum|DEFault]

:B SINE|SQUAre|TRIan|CSIN|DST<01..30>|USR<01..30>

:B?

:B

:MODE THD|AMP

:MODE?

:THD <value>|MINimum|MAXimum

:THD? [MINimum|MAXimum|DEFault]

:AMP <value>|MINimum|MAXimum

:AMP? [MINimum|MAXimum|DEFault]

```

[SOURce:] FUNCTION Command Table

Command	Description
[SOURce:]FUNCTION:SHAPE SINE SQUAre TRIan CSIN DST<01..30> USR<01..30> A B [SOURce:]FUNCTION:SHAPE?	Set the output waveform of the power mode.
[SOURce:]FUNCTION[:CSIN]:MODE THD AMP [SOURce:]FUNCTION[:CSIN]:MODE?	When the waveform is set to CSIN, select the calculation method for the clipped sine wave.

[SOURce:]FUNCTion:CSIN:THD <value> MINimum MAXimum [SOURce:]FUNCTion:CSIN:THD? [MINimum MAXimum DEFault]	Set the Total Harmonic Distortion (THD) value for the clipped sine wave in THD mode.
[SOURce:]FUNCTion:CSIN:AMP <value> MINimum MAXimum [SOURce:]FUNCTion:CSIN:AMP?	Set the amplitude residual ratio for the clipped sine wave in AMP mode.
[SOURce:]FUNCTion:SHAPe:A SINe SQUAre TRIan CSIN DST<01..30> USR<01..30> [SOURce:]FUNCTion:SHAPe:A?	Set the output waveform of Waveform Buffer A.
[SOURce:]FUNCTion:SHAPe:A:MODE THD AMP [SOURce:]FUNCTion:SHAPe:A:MODE?	When Buffer A's waveform is set to CSIN, select the calculation method for the clipped sine wave.
[SOURce:]FUNCTion:SHAPe:A:THD <value> MINimum MAXimum [SOURce:]FUNCTion:SHAPe:A:THD? [MINimum MAXimum DEFault]	Set the THD mode for Buffer A with the total harmonic distortion value of the clipped sine wave.
[SOURce:]FUNCTion:SHAPe:A:AMP <value> MINimum MAXimum [SOURce:]FUNCTion:SHAPe:A:AMP? [MINimum MAXimum DEFault]	Set the AMP mode for Buffer A with the amplitude residual ratio of the clipped sine wave.
[SOURce:]FUNCTion:SHAPe:B SINe SQUAre TRIan CSIN DST<01..30> USR<01..30> [SOURce:]FUNCTion:SHAPe:B?	Set the output waveform of Waveform Buffer B.
[SOURce:]FUNCTion:SHAPe:B:MODE THD AMP [SOURce:]FUNCTion:SHAPe:B:MODE?	When Buffer B's waveform is set to CSIN, select the calculation method for the clipped sine wave.
[SOURce:]FUNCTion:SHAPe:B:THD <value> MINimum MAXimum [SOURce:]FUNCTion:SHAPe:B:THD? [MINimum MAXimum DEFault]	Set the THD mode for Buffer B with the total harmonic distortion value of the clipped sine wave.

<code>[SOURce:]FUNCTion:SHAPe:B:AMP <value> MINimum MAXimum</code>	Set the AMP mode for Buffer B with
<code>[SOURce:]FUNCTion:SHAPe:B:AMP? [MINimum MAXimum DEFault]</code>	the amplitude residual ratio of the clipped sine wave.

`[SOURce:]FUNCTion:SHAPe SINE|SQUAre|TRIan|CSIN|DST<01..30>|USR<01..30> |A|B`

`[SOURce:]FUNCTion:SHAPe?`

Set the output waveform of the power mode

Parameter	Typical Response
SINE: Sine wave, SQUAre: Square wave, TRIan: Triangle wave, CSIN: Clipped sine wave, DST<130>: Built-in waveforms (30 sets), USR<130>: User-defined waveforms (30 sets), A: Buffer A, B: Buffer B	SINE
Example: Set the output waveform of the power mode to a sine wave.	
<code>FUNC:SHAP SINE</code>	

`[SOURce:]FUNCTion[:CSIN]:MODE THD|AMP`

`[SOURce:]FUNCTion[:CSIN]:MODE?`

When the waveform is set to CSIN, select the calculation method for the clipped sine wave

Parameter	Typical Response
THD: Determine the distortion level of the clipped sine wave based on the THD value	AMP
AMP: Determine the peak ratio of the clipped sine wave based on the AMP value	
Example: Set the clipped sine wave to use THD mode.	
<code>FUNC:MODE THD</code>	

`[SOURce:]FUNCTion:CSIN:THD <value>|MINimum|MAXimum`

`[SOURce:]FUNCTion:CSIN:THD?`

Set the total harmonic distortion (THD) value for the clipped sine wave in THD mode

Parameter	Typical Response
<NR2> , valid range: 0~43.0 (%)	5
Example: Set the desired THD value of the output CSIN waveform to 5%.	

FUNC:CSIN:THD 5

[SOURce:]FUNcTion:CSIN:AMPLitude <value>|MINimum|MAXimum

[SOURce:]FUNcTion:CSIN:AMPLitude?

Set the amplitude residual ratio for the clipped sine wave in AMP mode

Parameter	Typical Response
<NR2> , valid range: 0~100.0 (%)	95
Example: Set the desired amplitude of the output CSIN waveform to 95% of a full sine wave.	
FUNC:CSIN:AMP 95	

[SOURce:]FUNcTion:SHAPe:A SINE|SQUAre|TRIAN|CSIN|DST<01..30>|USR<01..30>

[SOURce:]FUNcTion:SHAPe:A?

Set the output waveform of Waveform Buffer A

Parameter	Typical Response
SINE: Sine wave, SQUAre: Square wave, TRIAn: Triangle wave, CSIN: Clipped sine wave, DST<130>: Built-in waveforms (30 sets), USR<130>: User-defined waveforms (30 sets)	TRIAN
Example: Set the output waveform of Waveform Buffer A to a triangle wave.	
FUNC:A TRIAN	

[SOURce:]FUNcTion:SHAPe:A:MODE THD|AMP

[SOURce:]FUNcTion:SHAPe:A:MODE?

When the waveform of Buffer A is set to CSIN, select the calculation method for the clipped sine wave

Parameter	Typical Response
THD: Determine the distortion level of the clipped sine wave based on the THD value	AMP
AMP: Determine the peak ratio of the clipped sine wave based on the AMP value	
Example: Set the clipped sine wave of Buffer A to use THD mode.	
FUNC:SHAP:A:MODE THD	

[SOURCE:]FUNCTION:SHAPE:A:THD <value>|MINimum|MAXimum

[SOURCE:]FUNCTION:SHAPE:A:THD? [MINimum|MAXimum|DEFAULT]

Set the THD mode for Buffer A and define the total harmonic distortion (THD) value of the clipped sine wave

Parameter	Typical Response
<NR2>, valid range: 0~43.0 (%)	5
Example: Set the desired THD value of the CSIN waveform output from Waveform Buffer A to 5%	
FUNC:A:THD 5	

[SOURCE:]FUNCTION:SHAPE:A:AMP <value>|MINimum|MAXimum

[SOURCE:]FUNCTION:SHAPE:A:AMP? [MINimum|MAXimum|DEFAULT]

Set the AMP mode for Buffer A and define the amplitude residual ratio of the clipped sine wave

Parameter	Typical Response
<NR2>, valid range: 0~100.0 (%)	5
Example: Set the desired amplitude of the CSIN waveform output from Waveform Buffer A to 95% of a full sine wave	
FUNC:A:AMP 95	

[SOURCE:]FUNCTION:SHAPE:B SINE|SQUAre|TRIan|CSIN|DST<01..30>|USR<01..30>

[SOURCE:]FUNCTION:SHAPE:B?

Set the output waveform of Waveform Buffer B

Parameter	Typical Response
SINE: Sine wave, SQUAre: Square wave, TRIan: Triangle wave, CSIN: Clipped sine wave, DST<130>: Built-in waveforms (30 sets), USR<130>: User-defined waveforms (30 sets)	SQUA
Example: Set the output waveform of Waveform Buffer B to a square wave.	
FUNC:B SQUA	

[SOURCE:]FUNCTION:SHAPE:B:MODE THD|AMP

[SOURCE:]FUNCTION:SHAPE:B:MODE?

When the waveform of Buffer B is set to CSIN, select the calculation method for the clipped sine wave

Parameter	Typical Response
THD: Determine the distortion level of the clipped sine wave based on the THD value	AMP
AMP: Determine the peak ratio of the clipped sine wave based on the AMP value	
Example: Set the clipped sine wave of Buffer B to use THD mode.	
FUNC:SHAP:B:MODE THD	

[SOURCE:]FUNCTION:SHAPE:B:THD <value>|MINimum|MAXimum

[SOURCE:]FUNCTION:SHAPE:B:THD? [MINimum|MAXimum|DEFAULT]

Set the THD mode for Buffer B and define the total harmonic distortion (THD) value of the clipped sine wave

Parameter	Typical Response
<NR2> , valid range: 0~43.0 (%)	5
Example: Set the desired THD value of the CSIN waveform output from Waveform Buffer B to 5%	
FUNC:B:THD 5	

[SOURCE:]FUNCTION:SHAPE:B:AMP <value>|MINimum|MAXimum

[SOURCE:]FUNCTION:SHAPE:B:AMP? [MINimum|MAXimum|DEFAULT]

Set the AMP mode for Buffer B and define the amplitude residual ratio of the clipped sine wave

Parameter	Typical Response
<NR2>, valid range: 0~100.0 (%)	5
Example: Set the desired amplitude of the CSIN waveform output from Waveform Buffer B to 95% of a full sine wave	
FUNC:B:AMP 95	

13.8 OUTPut Subsystem

OUTPut

```

[:STATe] ON|OFF

[:STATe]?

:PROTection

    :CLEar

    :STATe?

    :EVENT?

:MODE FIXED|LIST|PULSE|STEP|SYNTH|INTERHARM|TRANSIENT

:MODE?

:COUPling AC|DC|ACDC

:COUPling?

:RELay OFF|ON

:RELay?

:SLEW

    :VOLTage

        :AC

            [:ON] <value>|MINimum|MAXimum

            [:ON]? [MINimum|MAXimum|DEFault]

            :OFF <value>|MINimum|MAXimum

            :OFF? [MINimum|MAXimum|DEFault]

        :DC

            [:ON] <value>|MINimum|MAXimum

            [:ON]? [MINimum|MAXimum|DEFault]

            :OFF <value>|MINimum|MAXimum

```

```

:OFF? [MINimum|MAXimum|DEFault]

:OFF

:VOLTage

:DC <value>|MINimum|MAXimum

:DC? [MINimum|MAXimum|DEFault]

:FREQuency <value>|MINimum|MAXimum

:FREQuency? [MINimum|MAXimum|DEFault]

:IMPedance

[:STATe] ON|OFF

[:STATe]?

:RESistance[:LEVel] <value>|MINimum|MAXimum

:RESistance[:LEVel]? [MINimum|MAXimum|DEFault]

:{INDuctance|INDuction}[:LEVel] <value>|[MINimum|MAXimum]

:{INDuctance|INDuction}[:LEVel]? [MINimum|MAXimum|DEFault]

:RESPonse <value>|MINimum|MAXimum

:RESPonse? [MINimum|MAXimum|DEFault]

```

OUTPut Command Table

Command	Description
OUTPut[:STATe] ON OFF OUTPut[:STATe]?	Enable or disable voltage output in power mode
OUTPut:PROTection:CLEAr	Clear any triggered protection status
OUTPut:PROTection:STATe?	Query the current protection status
OUTPut:PROTection:EVENT?	Query protection events that have occurred
OUTPut:MODE FIXED LIST PULSE STEP SYNTH INTERHARM TRANSIENT OUTPut:MODE?	Set the output mode under power mode

OUTPut:COUPling AC DC ACDC OUTPut:COUPling?	Set the coupling method for voltage output in power mode
OUTPut:RELAy OFF ON OUTPut:RELAy?	Set the operating mode of the output relay
OUTPut:SLEW:VOLTAge:AC[:ON] <value> MINimum MAXimum OUTPut:SLEW:VOLTAge:AC[:ON]? [MINimum MAXimum DEFault]	Set the slew rate limit for AC voltage changes during output
OUTPut:SLEW:VOLTAge:AC:OFF <value> MINimum MAXimum OUTPut:SLEW:VOLTAge:AC:OFF? [MINimum MAXimum DEFault]	Set the slew rate limit when turning off AC voltage output
OUTPut:SLEW:VOLTAge:DC[:ON] <value> MINimum MAXimum OUTPut:SLEW:VOLTAge:DC[:ON]? [MINimum MAXimum DEFault]	Set the slew rate limit for DC voltage changes during output
OUTPut:SLEW:VOLTAge:DC:OFF <value> MINimum MAXimum OUTPut:SLEW:VOLTAge:DC:OFF? [MINimum MAXimum DEFault]	Set the slew rate limit when turning off DC voltage output
OUTPut:SLEW:OFF:VOLTAge:DC <value> MINimum MAXimum OUTPut:SLEW:OFF:VOLTAge:DC? [MINimum MAXimum DEFault]	Compatible command for OUTPut:SLEW:VOLTAge:DC:OFF
OUTPut:SLEW:FREQUency <value> MINimum MAXimum OUTPut:SLEW:FREQUency? [MINimum MAXimum DEFault]	Set the slew rate limit for frequency changes during output
OUTPut:IMPedance[:STATe] ON OFF OUTPut:IMPedance[:STATe]?	Enable or disable the output impedance function
OUTPut:IMPedance:RESistance[:LEVel] <value> MINimum MAXimum OUTPut:IMPedance:RESistance[:LEVel]? [MINimum MAXimum DEFault]	Set the resistance value for the output impedance function
OUTPut:IMPedance:{INDuctance INDuction} [:LEVel] <value> MINimum MAXimum OUTPut:IMPedance:{INDuctance INDuction} [:LEVel]? [MINimum MAXimum DEFault]	Set the inductance value for the output impedance function
OUTPut:RESPonse <value> MINimum MAXimum OUTPut:RESPonse? [MINimum MAXimum DEFault]	Set the response gain for output operation

OUTPut[:STATe] ON|OFF

OUTPut[:STATe]?

Enable or disable voltage output in power mode

Parameter	Typical Response
ON: Enable output	OFF
OFF: Disable output	
Example: Enable voltage output	
OUTP ON	

OUTPut:PROTection:CLEAr

Clear occurred protection events and status.

Parameter	Typical Response
Example: Clear a triggered protection status (for clearable protections, please refer to Table 7.1)	
OUTP:PROT:CLE	

OUTPut:PROTection:STATe?

Query protection status

Parameter	Typical Response
	ACTIVE: The device is currently in a protection state
	INACTIVE: No protection is currently active
Example: Query the protection status	
OUTP:PROT:STAT?	

OUTPut:PROTection:EVENT?

Query currently occurred protection events

Parameter	Typical Response
	"(1),HOST_DSP,SYS_PROT_COMM,12 .3,2024/08/30 03:05:51;" "(2),HOST_DSP,SYS_PWR_ OFF,3.0,2024/08/30 03:05:51;"
Example: Query protection events (please refer to Table 7.1/7.2 for details)	
OUTP:PROT:EVENT?	

OUTPut:MODE FIXED|LIST|PULSE|STEP|SYNTH|INTERHARM**OUTPut:MODE?**

Set the output mode under power mode

Parameter	Typical Response
(Refer to Chapter 5 for operation details)	FIXED
Example: Set the output mode under power mode to LIST mode	
OUTP:MODE LIST	

OUTPut:COUPLing AC|DC|ACDC**OUTPut:COUPLing?**

Set the coupling method for voltage output in power mode

Parameter	Typical Response
AC: Pure AC voltage output	ACDC
DC: Pure DC voltage output	
ACDC: Combined AC + DC voltage output	
Example: Set the voltage output coupling method in power mode to AC	
OUTP:COUP AC	

OUTPut:RELAy OFF|ON**OUTPut:RELAy?**

Set the operating mode of the output relay

Parameter	Typical Response
OFF: Output relay switches based on OUTPUT ON/OFF	OFF ON
ON: Output relay remains ON even when OUTPUT is OFF	
Example: Keep the output relay ON	
OUTP:REL ON	

OUTPut:SLEW:VOLTage:AC[:ON] <value>|MINimum|MAXimum**OUTPut:SLEW:VOLTage:AC[:ON]? [MINimum|MAXimum|DEFault]**

Set the slew rate limit for AC voltage changes during output

Parameter	Typical Response
-----------	------------------

<NR2> , valid range: 0.01~2000.00 (V/msec) 2000

Example: Set the slew rate limit for AC voltage rise/fall to 2000 V/msec

OUTP:SLEW:VOLT:AC 2000

OUTPut:SLEW:VOLTage:AC:OFF <value>|MINimum|MAXimum

OUTPut:SLEW:VOLTage:AC:OFF? [MINimum|MAXimum|DEFAULT]

Set the slew rate limit when turning off AC voltage output

Parameter	Typical Response
<NR2>, valid range: 0.01~2000.00 (V/msec)	2000
Example: Set the AC voltage fall slew rate limit when turning off output to 2000 V/msec	
OUTP:SLEW:VOLT:AC:OFF 2000	

OUTPut:SLEW:VOLTage:DC[:ON] <value>|MINimum|MAXimum

OUTPut:SLEW:VOLTage:DC[:ON?] [MINimum|MAXimum|DEFAULT]

Set the slew rate limit for DC voltage changes during output

Parameter	Typical Response
<NR2>, valid range: 0.01~2000.00 (V/msec)	2000
Example: Set the slew rate limit for DC voltage rise/fall to 2000 V/msec	
OUTP:SLEW:VOLT:DC 2000	

OUTPut:SLEW:VOLTage:DC:OFF <value>|MINimum|MAXimum

OUTPut:SLEW:VOLTage:DC:OFF? [MINimum|MAXimum|DEFAULT]

Set the slew rate limit when turning off DC voltage output

Parameter	Typical Response
<NR2>, valid range: 0.01~2000.00 (V/msec)	2000
Example: Set the DC voltage fall slew rate limit when turning off output to 2000.00 V/msec	
OUTP:SLEW:VOLT:DC:OFF 2000	

OUTPut:SLEW:FREQuency <value>|MINimum|MAXimum

OUTPut:SLEW:FREQuency? [MINimum|MAXimum|DEFAULT]

Set the slew rate limit for frequency changes during output

Parameter	Typical Response
<NR2>, valid range: 0.01~1000.00 (Hz/msec)	1000
Example: Set the frequency rise/fall slew rate limit to 1000 Hz/msec	
OUTP:SLEW:FREQ 1000	

OUTPut:IMPedance[:STATe] ON|OFF

OUTPut:IMPedance[:STATe]?

Enable or disable the output impedance function

Parameter	Typical Response
OFF: Output impedance function disabled	ON
ON: Output impedance function enabled	
Example: Disable the output impedance function	
OUTP:IMP OFF	

OUTPut:IMPedance:RESistance[:LEVel] <value>|MINimum|MAXimum

OUTPut:IMPedance:RESistance[:LEVel]? [MINimum|MAXimum|DEFAULT]

Set the resistance value for the output impedance function

Parameter	Typical Response
<NR2>, valid range: -1.000~1.000 (Ω)	0.01
Example: Set the resistance value of the output impedance function to 0.01 Ω	
OUTP:RES 0.01	

OUTPut:IMPedance:{INDuctance|INDuction}[:LEVel] <value>|MINimum|MAXimum

OUTPut:IMPedance:{INDuctance|INDuction}[:LEVel]? [MINimum|MAXimum|DEFAULT]

Set the inductance value for the output impedance function

Parameter	Typical Response
<NR2>, valid range: -1000~1000 (μ H)	100
Example: Set the inductance value of the output impedance function to 100 μ H	
OUTP:IND 100	

OUTPut:RESPonse <value>|MINimum|MAXimum

OUTPut: RESPonse? [MINimum|MAXimum|DEFAULT]

Set the response gain for output operation

Parameter	Typical Response
<NR1> , valid range: 1-15	8
Example: Set the response gain to 2	
OUTP:RESP 2	

13.9 TRIG Subsystem

TRIG OFF|ON|PAUSE|CONTINUE|UP|DOWN

STATe?

OUTPut Command Table

Command	Description
TRIG OFF ON PAUSE CONTINUE UP DOWN	Trigger a specific function in advanced mode
TRIG:STATe?	Query the current status of a specific function in advanced mode

TRIG OFF|ON|PAUSE|CONTINUE|UP|DOWN

Trigger a specific function in advanced mode

Parameter	Typical Response
OFF: Stop advanced mode operation	
ON: Trigger advanced mode operation	
PAUSE: Pause advanced mode operation (STEP or INTERHARM mode)	
CONTINUE: Continue advanced mode operation (STEP or INTERHARM mode)	
UP: Trigger the previous STEP operation (STEP mode)	
DOWN: Trigger the next STEP operation (STEP mode)	
Example: Trigger operation in LIST mode	
TRIG ON	

TRIG:STATe?

Query the current status of a specific function in advanced mode

Parameter	Typical Response
OFF: Advanced mode is currently stopped	RUNNING
RUNNING: Advanced mode is currently running	
PAUSE: Advanced mode is currently paused	
Example: Query the current status of advanced mode	
TRIG:STAT?	

13.10 PHASe Subsystem

:PHASe

:FUNction SINGLE|THREE|SPLIT

:FUNction?

:{MODE|THREE} INDEPEND|SAMEFREQ|BALANCE

:{MODE|THREE}?

[:THREE]

:BALanced PHASE|LINE

:BALanced?

:RELOCK DISABLE|ENABLE

:RELOCK?

:SPLit

:MODE INDEPEND|BALANCE

:{START|ON} <value>|MINimum|MAXimum|DEFault

:{START|ON}? [MINimum|MAXimum|DEFault]

:{END|OFF} <value>|MINimum|MAXimum|DEFault

:{END?|OFF} [MINimum|MAXimum|DEFault]

[:ANGLE]

:P12 <value>|MINimum|MAXimum|DEFault

:P12? [MINimum|MAXimum|DEFault]

:P13 <value>|MINimum|MAXimum|DEFault

:P13? [MINimum|MAXimum|DEFault]

:SEQUence POSITIVE|NEGATIVE

:SEQUence?

PHASe Command Table

Command	Description
PHASe:FUNcTION SINGLE THREE SPLIT PHASe:FUNcTION?	Set the phase mode in power mode
PHASe:MODE INDEPEND SAMEFREQ BALANCE PHASe:MODE?	Set the operation mode under three-phase output
PHASe:THREE INDEPEND SAMEFREQ BALANCE PHASe:THREE?	Compatible command for PHASe:MODE
PHASe[:THREE]:BALanced PHASE LINE PHASe[:THREE]:BALanced?	In three-phase balanced mode, set AC voltage display to phase voltage or line voltage
PHASe[:THREE]:RELOCK DISABLE ENABLE PHASe[:THREE]:RELOCK?	In three-phase independent mode, enable or disable phase angle resynchronization
PHASe:START:ANGLE DEGRee IMMEDIATE PHASe:START: ANGLE?	Set whether the output waveform ends at a specified angle or ends immediately (random angle)
PHASe:START[:DEGRee] <value> MINimum MAXimum DEFault PHASe:START[:DEGRee]? [MINimum MAXimum DEFault]	Set the starting angle of the output waveform
PHASe:ON <value> MINimum MAXimum DEFault PHASe:ON? [MINimum MAXimum DEFault]	Compatible command for PHASe:START
PHASe:END:ANGLE DEGRee IMMEDIATE PHASe:END: ANGLE?	Set whether the output waveform ends at a specified angle or ends immediately (random angle)

PHASe:END[:DEGRee] <value> MINimum MAXimum DEFault PHASe:END[:DEGRee]? [MINimum MAXimum DEFault]	Set the ending angle of the output waveform
PHASe:OFF <value> MINimum MAXimum DEFault PHASe:OFF? [MINimum MAXimum DEFault]	Compatible command for PHASe:END
PHASe[:ANGLE]:P12 <value> MINimum MAXimum DEFault PHASe[:ANGLE]:P12? [MINimum MAXimum DEFault]	Set the phase difference between $\Phi 1$ and $\Phi 2$
PHASe[:ANGLE]:P13 <value> MINimum MAXimum DEFault PHASe[:ANGLE]:P13? [MINimum MAXimum DEFault]	Set the phase difference between $\Phi 1$ and $\Phi 3$
PHASe:SEquence POSITIVE NEGATIVE PHASe:SEquence?	Set the phase sequence (positive or negative) in three-phase mode

PHASe:FUNCtion SINGLE|THREE|SPLIT**PHASe:FUNCtion? SINGLE|THREE|SPLIT**

Set the phase mode in power mode

Parameter	Typical Response
SINGLE: Single-phase mode	THREE
THREE: Three-phase mode	
SPLIT: Single-phase three-wire / split-phase mode	
Example: Set the phase mode in power mode to Three-phase	
PHAS:FUNC THREE	

PHASe:MODE|THREE INDEPEND|SAMEFREQ|BALANCE**PHASe:MODE|THREE? INDEPEND|SAMEFREQ|BALANCE**

Set the operation mode under three-phase output

Parameter	Typical Response
INDEPEND: Three-phase independent configuration	BALANCE
SAMEFREQ: Equal frequency across three phases (only frequency is the same)	
BALANCE: Fully balanced three-phase output (equal voltage and frequency)	
Example: Set the three-phase output operation mode to Balanced	
PHAS:MODE BALANCE	

PHASe[:THREE]:BALanced PHASE|LINE**PHASe[:THREE]:BALanced?**

Set AC voltage display to phase voltage or line voltage in three-phase balanced mode

Parameter	Typical Response
PHASE: Display phase voltage	PHASE
LINE: Display line voltage	
Example: Set the display in three-phase balanced mode to line voltage	
PHAS: BAL LINE	

PHASe[:THREE]:RELOCK DISABLE|ENABLE**PHASe[:THREE]:RELOCK?**

Enable or disable phase angle resynchronization in three-phase independent mode

Parameter	Typical Response
DISABLE: Disable resynchronization in three-phase independent mode	DISABLE
ENABLE: Enable resynchronization in three-phase independent mode	
Example: Enable resynchronization in three-phase independent mode	
PHAS:RELOCK ENABLE	

PHASe:START:ANGLE DEGREE|IMMEDIATE**PHASe:START: ANGLE?**

Set whether the output waveform starts at a specified angle or immediately (random angle)

Parameter	Typical Response
DEGREE: Output waveform starts at a specified angle	IMMEDIATE
IMMEDIATE: Output waveform starts immediately at a random angle	
Example: Set the output waveform to start immediately at a random angle	
PHAS:STAR:ANGL IMMEDIATE	

PHASe:START|ON <value>|MINimum|MAXimum|DEFault**PHASe:START|ON? [MINimum|MAXimum|DEFault]**

Set the starting angle of the output waveform

Parameter	Typical Response
-----------	------------------

<NR2> , valid range: 0.0~359.9 0

Example: Set the starting angle of the waveform to 0 degrees

PHAS:STAR 0

PHASe:END:ANGLE DEGREE|IMMEDIATE

PHASe:END: ANGLE?

Set the end of the output waveform to either reference a specified angle or end immediately (at a random angle).

Parameter	Typical Response
DEGREE: Output waveform ends at a specified angle	DEGREE
IMMEDIATE: Output waveform ends immediately at a random angle	

Example: Set the output waveform to end at a specific angle, according to the value set by PHASE:END

PHAS:STAR:ANGL DEGR

PHASe:END|OFF <value>|MINIMUM|MAXIMUM|DEFAULT

PHASe:END|OFF? [MINIMUM|MAXIMUM|DEFAULT]

Set the ending angle of the output waveform

Parameter	Typical Response
<NR2> , valid range: 0.0~359.9	0

Example: Set the ending angle of the waveform to 0 degrees

PHAS:END 0

PHASe[:ANGLE]:P12 <value>|MINIMUM|MAXIMUM|DEFAULT

PHASe[:ANGLE]:P12? [MINIMUM|MAXIMUM|DEFAULT]

Set the phase difference between $\Phi 1$ and $\Phi 2$

Parameter	Typical Response
<NR2> , valid range: 0.0~359.9	120

Example: Set the phase difference between $\Phi 1$ and $\Phi 2$ to 120 degrees

PHAS:P12 120

PHASe[:ANGLE]:P13 <value>|MINIMUM|MAXIMUM|DEFAULT

PHASe[:ANGLE]:P13? [MINimum|MAXimum|DEFault]

Set the phase difference between $\Phi 1$ and $\Phi 3$

Parameter	Typical Response
<NR2>, valid range: 0.0~359.9	240
Example: Set the phase difference between $\Phi 1$ and $\Phi 3$ to 240 degrees	
PHAS:P13 240	

PHASe:SEQUence POSITIVE|NEGATIVE**PHASe:SEQUence?**

Set the phase sequence in three-phase mode

Parameter	Typical Response
NEGATIVE: Negative phase sequence	NEGATIVE
POSITIVE: Positive phase sequence	
Example: Set the three-phase mode to positive phase sequence	
PHAS:SEQ POSITIVE	

13.11 FETCh and MEASure Subsystems

MEASure|FETCh[:SCALar]

:ALL? [<Phase>]

:CURRent

:AC?

:DC?

:ACDC?

:AMPLitude

:MAXimum?

:MAXimum

:POSitive?

:NEGative?
:CREStfactor?
:INRush?
:HARMonic
[:AMPLitude]? [<Phase>]
:{DISTort|PERcent}? [<Phase>]
:PHASe? [<Phase>]
:THD? [<Phase>]
:FUNDamental?
:ARRay?
:FREQuency
[:AMPLitude]?
:INTERHARmonics?
:INTERHARmonics
:FREQuency?
:POWER
[:ACDC]
:[REAL]?
:APParent?
:REACtive?
:PFACTOR?
:TOTal?
:TOTal:APParent?
:AC
:[REAL]?
:APParent?

:REACTive?

:PFACtor?

:TOTal?

:TOTal:APParent?

:VOLTage

[:ACDC]?

:AC?

:DC?

:AMPLitude

:MAXimum?

:MAXimum

:POSitive?

:NEGative?

:LINE

:V12?

:V23?

:V31?

:HARMonic

[:AMPLitude]? [<Phase>]

:{DISTort|PERcent}? [<Phase>]

:PHASe? [<Phase>]

:THD? [<Phase>]

:FUNDamental?

:HARMonic

:THD?

:FUNDamental?

:ARRay? [<value>, ..., <value>]

:WAVE

:CAPTure

:VOLTage

:DATA? [<Phase>]

:CURRent

:DATA? [<Phase>]

:TIME

:SCALE

:SCALE?

MEASure|FETCh Command Table

Command	Description
MEASure FETCh[:SCALar]:ALL?	Read all measurement values
MEASure FETCh[:SCALar]:CURRent:AC?	Read the RMS value of the AC component of current
MEASure FETCh[:SCALar]:CURRent:DC?	Read the RMS value of the DC component of current
MEASure FETCh[:SCALar]:CURRent:ACDC?	Read the RMS value of the current (AC + DC)
MEASure FETCh[:SCALar]:CURRent:AMPLitude:MAXimum?	Read the peak current measurement value
MEASure FETCh[:SCALar]:CURRent:AMPLitude:MAXimum:POSitive?	Read the positive peak current value
MEASure FETCh[:SCALar]:CURRent:AMPLitude:MAXimum:NEGative?	Read the negative peak current value
MEASure FETCh[:SCALar]:CURRent:CREStfactor?	Read the crest factor of the current
MEASure FETCh[:SCALar]:CURRent:INRush?	Read the inrush current measurement value
MEASure FETCh[:SCALar]:CURRent:HARMonic[:AMPLitude]?	Read the RMS values of each harmonic component

MEASure FETCh[:SCALar]:CURRent:HARMonic:DISToRt PERcent? <NR1>	Read the percentage values of each harmonic component
MEASure FETCh[:SCALar]:CURRent:HARMonic:PHASe? [<NR1>]	Read the phase angle of each harmonic component
MEASure FETCh[:SCALar]:CURRent:HARMonic:THD?	Read the total harmonic distortion (THD) percentage of current
MEASure FETCh[:SCALar]:FREQuency[:AMPLitude]?	Read the frequency measurement value
MEASure FETCh[:SCALar]:FREQuency:INTERHARmonics? MEASure FETCh[:SCALar]:INTERHARmonics:FREQuency?	Read the interharmonic frequency value
MEASure FETCh[:SCALar]:POWer[:ACDC]:[REAL]?	Read the real power measurement value
MEASure FETCh[:SCALar]:POWer[:ACDC]:APParent?	Read the apparent power measurement value
MEASure FETCh[:SCALar]:POWer[:ACDC]:REACTive?	Read the reactive power measurement value
MEASure FETCh[:SCALar]:POWer[:ACDC]:PFACtor?	Read the power factor measurement value
MEASure FETCh[:SCALar]:POWer[:ACDC]:TOTal?	Read the total real power
MEASure FETCh[:SCALar]:POWer[:ACDC]:TOTal:APParent?	Read the total apparent power
MEASure FETCh[:SCALar]:POWer:AC:[REAL]?	Read the real power of the AC component
MEASure FETCh[:SCALar]:POWer:AC:APParent?	Read the apparent power of the AC component
MEASure FETCh[:SCALar]:POWer:AC:REACTive?	Read the reactive power of the AC component
MEASure FETCh[:SCALar]:POWer:AC:PFACtor?	Read the power factor of the AC component
MEASure FETCh[:SCALar]:POWer:AC:TOTal?	Read the total real power of the AC component
MEASure FETCh[:SCALar]:POWer:AC:TOTal:APParent?	Read the total apparent power of the AC component
MEASure FETCh[:SCALar]:POWer:DC:TOTal?	Read the total real power of the DC component
MEASure FETCh[:SCALar]:VOLTage[:ACDC]?	Read the RMS voltage value
MEASure FETCh[:SCALar]:VOLTage:AC?	Read the RMS value of the AC component of voltage

MEASure FETCh[:SCALar]:VOLTage:DC?	Read the RMS value of the DC component of voltage
MEASure FETCh[:SCALar]:VOLTage:AMPLitude:MAXimum?	Read the peak voltage measurement value
MEASure FETCh[:SCALar]:VOLTage:AMPLitude:MAXimum:POSitive?	Read the positive peak voltage measurement value
MEASure FETCh[:SCALar]:VOLTage:AMPLitude:MAXimum:NEGative?	Read the negative peak voltage measurement value
MEASure FETCh[:SCALar]:VOLTage:LINE:V12?	Read the RMS value of line voltage V12
MEASure FETCh[:SCALar]:VOLTage:LINE:V23?	Read the RMS value of line voltage V23
MEASure FETCh[:SCALar]:VOLTage:LINE:V31?	Read the RMS value of line voltage V32
MEASure FETCh[:SCALar]:VOLTage:HARMonic[:AMPLitude]?	Read the RMS values of each harmonic component
MEASure FETCh[:SCALar]:VOLTage:HARMonic:{DISTort PERcent} ? <NR1>	Read the percentage values of each harmonic component
MEASure FETCh[:SCALar]:VOLTage:HARMonic:PHASe? [<NR1>]	Read the phase angle of each harmonic component
MEASure FETCh[:SCALar]:VOLTage:HARMonic:THD?	Read the total harmonic distortion (THD) percentage of voltage
MEASure FETCh[:SCALar]:WAVE:CAPTure	Trigger the procedure to refresh the data captured from the DSP output waveform.
MEASure FETCh[:SCALar]:WAVE:VOLTage:DATA?	Read the voltage waveform
MEASure FETCh[:SCALar]:WAVE:CURREnt:DATA?	Read the current waveform
MEASure FETCh[:SCALar]:WAVE:TIME:SCALE	Set the time scale of the waveform
MEASure FETCh[:SCALar]:WAVE:SCALE?	Query the time scale of the waveform

MEASure|FETCh[:SCALar]:ALL?

<Vac>,<Vdc>,<Vrms>,<Vpeak>,<IAC>,<IDC>,<Irms>,<Ipeak>,<linrush>,<Freq>,<Pavg>,<VA>,<VAR>,<PF>
>,<CF>,<Total_P>,<Total_VA>,<V12>,<V23>,<V31>,< Total_PF>

Read all measurement values

Parameter	Typical Response
	100.0,0,100.0,141.4,0,0,.....

Example:

MEAS:ALL?

MEASure|FETCh[:SCALar]:CURRent:AC?

Read the RMS value of the AC component of current

Parameter	Typical Response
	100.0

Example:

MEAS:CURR:AC?

MEASure|FETCh[:SCALar]:CURRent:DC?

Read the RMS value of the DC component of current

Parameter	Typical Response

Example:

MEAS:CURR:DC?

MEASure|FETCh[:SCALar]:CURRent:ACDC?

Read the RMS value of current (AC + DC)

Parameter	Typical Response

Example:

MEAS:CURR:ACDC?

MEASure|FETCh[:SCALar]:CURRent:AMPLitude:MAXimum?

Read the peak current measurement value

Parameter	Typical Response

Example:

MEAS:CURR:AMPL:MAX?

MEASure|FETCh[:SCALar]:CURRent:AMPLitude:MAXimum:POSitive?

Read the positive peak current measurement value

Parameter	Typical Response
-----------	------------------

Example:

MEAS:CURR:AMPL:MAX:POS?

MEASure|FETCh[:SCALar]:CURRent:AMPLitude:MAXimum:NEGative?

Read the negative peak current measurement value

Parameter	Typical Response
	+2.50000E+02

Example:

MEAS:CURR:AMPL:MAX:NEG?

MEASure|FETCh[:SCALar]:CURRent:CREStfactor?

Read the crest factor of the current

Parameter	Typical Response
-----------	------------------

Example:

MEAS:CURR:CRES?

MEASure|FETCh[:SCALar]:CURRent:INRush?

Read the inrush current measurement value

Parameter	Typical Response
-----------	------------------

Example:

MEAS:CURR:INR?

MEASure|FETCh[:SCALar]:CURRent:HARMonic[:AMPLitude]? <order>

Read the RMS values of each harmonic component

Parameter	Typical Response
Example:	
MEAS:CURR:HARM? 5	// Returns only the RMS value of the 5th harmonic component
MEAS:CURR:HARM?	// Returns the RMS values of harmonic components from the 1st to the 50th order only

MEASure|FETCh[:SCALar]:CURRent:HARMonic:DISToRt|PERcent? <NR1>

Read the percentage values of each harmonic component

Parameter	Typical Response
Example:	
MEAS:CURR:HARM:PER? 5	// Returns only the percentage value of the 5th harmonic component
MEAS:CURR:HARM:PPER?	// Returns the percentage values of harmonic components from the 1st to the 50th order only

MEASure|FETCh[:SCALar]:CURRent:HARMonic:PHASe? [<NR1>

Read the phase angle of each harmonic component

Parameter	Typical Response
Example:	
MEAS:CURR:HARM:PHAS? 5	// Returns only the phase angle value of the 5th harmonic component
MEAS:CURR:HARM:PHAS?	// Returns the phase angle values of harmonic components from the 1st to the 50th order only

MEASure|FETCh[:SCALar]:CURRent:HARMonic:THD?

Read the total harmonic distortion (THD) percentage of current

Parameter	Typical Response
Example:	
MEAS:CURR:HARM:THD?	

MEASure|FETCh[:SCALar]:FREQuency[:AMPLitude]?

Read the frequency measurement value

Parameter	Typical Response
Example: MEAS:FREQ?	

MEASure|FETCh[:SCALar]:FREQuency:INTERHARmonics?**MEASure|FETCh[:SCALar]:INTERHARmonics:FREQuency?**

Read the interharmonic frequency value

Parameter	Typical Response
Example: MEAS:FREQ:INTERHAR? MEAS:INTERHAR:FREQ?	

MEASure|FETCh[:SCALar]:POWer[:ACDC]:[REAL]?

Read the real power measurement value

Parameter	Typical Response
Example: MEAS:POW?	

MEASure|FETCh[:SCALar]:POWer[:ACDC]:APParent?

Read the apparent power measurement value

Parameter	Typical Response
Example: MEAS:POW:APP?	

MEASure|FETCh[:SCALar]:POWer[:ACDC]:REACTive?

Read the reactive power measurement value

Parameter	Typical Response
-----------	------------------

Example:

MEAS:POW:REAC?

MEASure|FETCh[:SCALar]:POWer[:ACDC]:PFActor?

Read the power factor measurement value

Parameter	Typical Response
-----------	------------------

Example:

MEAS:POW:PFAC?

MEASure|FETCh[:SCALar]:POWer[:ACDC]:TOTal?

Read the total real power

Parameter	Typical Response
-----------	------------------

Example:

MEAS:POW:TOT?

MEASure|FETCh[:SCALar]:POWer[:ACDC]:TOTal:APParent?

Read the total apparent power

Parameter	Typical Response
-----------	------------------

Example:

MEAS:POW:TOT:APP?

MEASure|FETCh[:SCALar]:POWer:AC:[REAL]?

Read the real power measurement value (for compatible competitor use only)

Parameter	Typical Response
-----------	------------------

Example:

MEAS:POW:AC?

MEASure|FETCh[:SCALar]:POWer:AC:APParent?

Read the apparent power measurement value (for compatible competitor use only)

Parameter	Typical Response
Example: MEAS:POW:AC:APP?	

MEASure|FETCh[:SCALar]:POWer:AC:REACtive?

Read the reactive power measurement value (for compatible competitor use only)

Parameter	Typical Response
Example: MEAS:POW:AC:REAC?	

MEASure|FETCh[:SCALar]:POWer:AC:PFACtor?

Read the power factor measurement value (for compatible competitor use only)

Parameter	Typical Response
Example: MEAS:POW:AC:PFAC?	

MEASure|FETCh[:SCALar]:POWer:AC:TOTal?

Read the total real power (for compatible competitor use only)

Parameter	Typical Response
Example: MEAS:POW:AC:TOT?	

MEASure|FETCh[:SCALar]:POWer:AC:TOTal:APParent?

Read the total apparent power (for compatible competitor use only)

Parameter	Typical Response
-----------	------------------

Example:

MEAS:POW:AC:TOT:APP?

MEASure|FETCh[:SCALar]:POWer:DC:TOTal?

Read the total real power of the DC component, please ask PM to decide whether this function needs to be enabled.

Parameter	Typical Response
-----------	------------------

Example:

MEAS:POW:DC:TOT?

MEASure|FETCh[:SCALar]:VOLTage[:ACDC]?

Read the RMS voltage value

Parameter	Typical Response
-----------	------------------

Example:

MEAS:VOLT?

MEASure|FETCh[:SCALar]:VOLTage:AC?

Read the RMS value of the AC component of voltage

Parameter	Typical Response
-----------	------------------

Example:

MEAS:VOLT:AC?

MEASure|FETCh[:SCALar]:VOLTage:DC?

Read the RMS value of the DC component of voltage

Parameter	Typical Response
-----------	------------------

Example:

MEAS:VOLT:DC?

MEASure|FETCh[:SCALar]:VOLTage:AMPLitude:MAXimum?

Read the peak voltage measurement value

Parameter	Typical Response
Example: MEAS:VOLT:AMPL:MAX?	

MEASure|FETCh[:SCALar]:VOLTage:AMPLitude:MAXimum:POSitive?

Read the positive peak voltage measurement value

Parameter	Typical Response
Example: MEAS:VOLT:AMPL:MAX:POS?	+2.50000E+02

MEASure|FETCh[:SCALar]:VOLTage:AMPLitude:MAXimum:NEGative?

Read the negative peak voltage measurement value

Parameter	Typical Response
Example: MEAS:VOLT:AMPL:MAX:NEG?	

MEASure|FETCh[:SCALar]:VOLTage:LINE:V12?

Read the RMS value of line voltage V12

Parameter	Typical Response
Example: MEAS:VOLT:LINE:V12?	

MEASure|FETCh[:SCALar]:VOLTage:LINE:V23?

Read the RMS value of line voltage V23

Parameter	Typical Response
-----------	------------------

Example:

MEAS:VOLT:LINE:V23?

MEASure|FETCh[:SCALar]:VOLTage:LINE:V31?

Read the RMS value of line voltage V32

Parameter	Typical Response
-----------	------------------

Example:

MEAS:VOLT:LINE:V31?

MEASure|FETCh[:SCALar]:VOLTage:HARMonic[:AMPLitude]?

Read the RMS values of each harmonic component

Parameter	Typical Response
-----------	------------------

Example:

MEAS:VOLT:HAR?

MEASure|FETCh[:SCALar]:VOLTage:HARMonic:{DISTort|PERcent}? <NR1>

Read the percentage values of each harmonic component

Parameter	Typical Response
-----------	------------------

Example:

MEAS:VOLT:HAR:PER?

MEASure|FETCh[:SCALar]:VOLTage:HARMonic:PHASe? [<NR1>]

Read the phase angle of each harmonic component

Parameter	Typical Response
	+2.50000E+02

Example:

MEAS:VOLT:HAR:PHAS?

MEASure|FETCh[:SCALar]:VOLTage:HARMonic:THD?

Read the total harmonic distortion (THD) percentage of voltage

Parameter	Typical Response
	+2.50000E+02

Example:

MEAS:VOLT:HAR:THD?

MEASure|FETCh[:SCALar]:VOLTage:HARMonic:FUNDamental?

Read the RMS value of the fundamental voltage

Parameter	Typical Response

Example:

MEAS:VOLT:HAR:FUND?

MEASure|FETCh[:SCALar]:VOLTage:HARMonic:ARRay?

Read the RMS values of each harmonic component

Parameter	Typical Response

Example:

MEAS:VOLT:HAR:ARR?

13.12 [SOURce:]LIST Subsystem

[SOURce:]LIST

:TRIG AUTO|MANUAL|EXCITE

:TRIG?

:{POINTs|TOTal}?

:BASE CYCLE|TIME

:BASE?

:COUNT|LOOP <value>|MINimum|MAXimum|DEFault

```

:COUNT|LOOP? [MINimum|MAXimum|DEFault]

:PCONTinue DISABLE|ENABLE

:PCONTinue?

:APPLY P1|P2|P3

:CLEar P1|P2|P3

[:SEQUence]

    :ALL?

    :ADD <seq>[,...,<degree>]

    :DELeTe <seq>

    :EDIT <seq>[,...,<degree>]

    :EDIT?

    :INSert <seq>[,...,<degree>]

    :COPY < seq >

    :DWELl <value>|MINimum|MAXimum|DEFault

    :DWELl? [MINimum|MAXimum|DEFault]

    :CYCLe <value>|MINimum|MAXimum|DEFault

    :CYCLe? [MINimum|MAXimum|DEFault]

    :SHAPE SINE|SQUA|TRIAN|CSIN|DST<01..30>|USR<01..30>

    :SHAPE?

        :CSIN

            :MODE THD|AMP

            :MODE?

            :THD <value>|MINimum|MAXimum|DEFault

            :THD? [MINimum|MAXimum|DEFault]

            :AMP <value>|MINimum|MAXimum|DEFault

            :AMP? [MINimum|MAXimum|DEFault]

```

:VOLTage

:AC

:START <value>|MINimum|MAXimum|DEFault

:START? [MINimum|MAXimum|DEFault]

:END <value>|MINimum|MAXimum|DEFault

:END? [MINimum|MAXimum|DEFault]

:DC

:START <value>|MINimum|MAXimum|DEFault

:START? [MINimum|MAXimum|DEFault]

:END <value>|MINimum|MAXimum|DEFault

:END? [MINimum|MAXimum|DEFault]

:FREQuency

:START <value>|MINimum|MAXimum|DEFault

:START? [MINimum|MAXimum|DEFault]

:END <value>|MINimum|MAXimum|DEFault

:END? [MINimum|MAXimum|DEFault]

:DEGRee <value>|MINimum|MAXimum|DEFault

:DEGRee? [MINimum|MAXimum|DEFault]

[SOURce:]LIST Command Table

Command	Description
[SOURce:]LIST:TRIG AUTO MANUAL EXCITE [SOURce:]LIST:TRIG?	Set the trigger method for LIST mode
[SOURce:]LIST:POINts TOTal?	Query the total sequence count of the currently edited phase.
[SOURce:]LIST:BASE TIME CYCLE [SOURce:]LIST:BASE?	Set the time configuration method for the sequence

[SOURce:]LIST:COUNT LOOP <value> MINimum MAXimum DEFault [SOURce:]LIST:COUNT LOOP? [MINimum MAXimum DEFault]	Set the total number of executions for the entire LIST program
[SOURce:]LIST:PCONTinue DISABLE ENABLE [SOURce:]LIST:PCONTinue?	Set whether the waveform between sequences starts at zero crossing or continues from the ending angle of the previous waveform
[SOURce:]LIST:POINts TOTal?	Query the total number of sequences for the currently edited phase
[SOURce:]LIST:APPLy P1 P2 P3	Apply all sequences of a specified phase to all phases
[SOURce:]LIST:CLEar P1 P2 P3	Clear all sequences of a specified phase
[SOURce:]LIST[:SEQuence]:ADD [,...,<degree>]	Add a new sequence with default values at the end of the current phase
[SOURce:]LIST[:SEQuence]:DELeTe <seq>	Delete a specified sequence by index from the current phase
[SOURce:]LIST[:SEQuence]:INSert <seq>[,...,<degree>]	Insert a new sequence with default values before a specified sequence in the current phase
[SOURce:]LIST[:SEQuence]:EDIT <seq>[,...,<degree>] [SOURce:]LIST[:SEQuence]:EDIT?	Specify the index of the sequence currently being edited in the current phase
[SOURce:]LIST[:SEQuence]:COpy <seq>	Insert a new sequence with the same parameters as the currently edited sequence after the

	specified sequence in the current phase
[SOURce:]LIST[:SEQuence]:ALL?	Query all parameter values of the current sequence in the current phase at once
[SOURce:]LIST[:SEQuence]:DWEI <value> MINimum MAXimum DEFault [SOURce:]LIST[:SEQuence]:DWEI? [MINimum MAXimum DEFault]	Set the duration (time) of this sequence
[SOURce:]LIST[:SEQuence]:CYCLe <value> MINimum MAXimum DEFault [SOURce:]LIST[:SEQuence]:CYCLe? [MINimum MAXimum DEFault]	Set the cycle count of this sequence
[SOURce:]LIST[:SEQuence]:SHAPE A B SINE SQUA TRIAN CSIN DST<01..30> USR<01..30> [SOURce:]LIST[:SEQuence]:SHAPE?	Set the output waveform of this sequence
[SOURce:]LIST[:SEQuence]:CSIN:MODE THD AMP [SOURce:]LIST[:SEQuence]:CSIN:MODE?	Set the configuration mode of CSIN waveform in this sequence
[SOURce:]LIST[:SEQuence]:CSIN:THD <value> MINimum MAXimum DEFault [SOURce:]LIST[:SEQuence]:CSIN:THD? [MINimum MAXimum DEFault]	Set the THD value of the CSIN waveform in this sequence
[SOURce:]LIST[:SEQuence]:CSIN:AMP <value> MINimum MAXimum DEFault [SOURce:]LIST[:SEQuence]:CSIN:AMP? [MINimum MAXimum DEFault]	Set the AMP value of the CSIN waveform in this sequence
[SOURce:]LIST[:SEQuence]:VOLTage:AC:START <value> MINimum MAXimum DEFault [SOURce:]LIST[:SEQuence]:VOLTage:AC:START? [MINimum MAXimum DEFault]	Set the starting AC voltage value of this sequence
[SOURce:]LIST[:SEQuence]:VOLTage:AC:END <value> MINimum MAXimum DEFault [SOURce:]LIST[:SEQuence]:VOLTage:AC:END? [MINimum MAXimum DEFault]	Set the ending AC voltage value of this sequence
[SOURce:]LIST[:SEQuence]:VOLTage:DC:START <value> MINimum MAXimum DEFault [SOURce:]LIST[:SEQuence]:VOLTage:DC:START? [MINimum MAXimum DEFault]	Set the starting DC voltage value of this sequence

[SOURce:]LIST[:SEQuence]:VOLTage:DC:END <value> MINimum MAXimum DEFault [SOURce:]LIST[:SEQuence]:VOLTage:DC:END? [MINimum MAXimum DEFault]	Set the ending DC voltage value of this sequence
[SOURce:]LIST[:SEQuence]:FREQuency:START <value> MINimum MAXimum DEFault [SOURce:]LIST[:SEQuence]:FREQuency:START? [MINimum MAXimum DEFault]	Set the starting frequency value of this sequence
[SOURce:]LIST[:SEQuence]:FREQuency:END <value> MINimum MAXimum DEFault [SOURce:]LIST[:SEQuence]:FREQuency:END? [MINimum MAXimum DEFault]	Set the ending frequency value of this sequence
[SOURce:]LIST[:SEQuence]:DEGRee <value> MINimum MAXimum DEFault [SOURce:]LIST[:SEQuence]:DEGRee? [MINimum MAXimum DEFault]	Set the starting angle of this sequence

[SOURce:]LIST:TRIG:COUPling ALL|NONE

[SOURce:]LIST:TRIG:COUPling?

Compatible

Parameter	Typical Response
Example:	

[SOURce:]LIST:TRIG AUTO|MANUAL|EXCITE

[SOURce:]LIST:TRIG?

Set the trigger mode

Parameter	Typical Response
AUTO: Execute the entire LIST program automatically	AUTO MANUAL EXCITE
MANUAL: Execute the LIST program once manually	
EXCITE: Execute the entire LIST program via external trigger	
Example: Set the trigger mode to AUTO	
LIST:TRIG AUTO	

[SOURCE:]LIST:POINTS|TOTAL?

Query the total number of sequences in the currently edited phase

Parameter	Typical Response
	30
Example:	
INST:NSEL 2	
LIST:POIN?	

[SOURCE:]LIST:BASE TIME|CYCLE**[SOURCE:]LIST:BASE?**

Set the time configuration method for the sequence

Parameter	Typical Response
TIME: Use time-based sequence duration	TIME CYCLE
CYCLE: Use cycle-based sequence duration	
Example: Set the sequence time configuration method to TIME	
LIST:BASE TIME	

[SOURCE:]LIST:COUNT|LOOP <value>|MINimum|MAXimum|DEFAULT**[SOURCE:]LIST:COUNT|LOOP? [MINimum|MAXimum|DEFAULT]**

Set the total number of executions for the entire LIST program

Parameter	Typical Response
<NR1>, valid range: 1 ~ 99999; 0 = continuous loop without stopping	1
1	
Example: Set the LIST program to run once	
LIST: LOOP 1	

[SOURCE:]LIST:PCONTinue DISABLE|ENABLE**[SOURCE:]LIST:PCONTinue?**

Set whether the waveform between sequences starts from a zero-crossing angle or continues from the previous waveform's ending angle

Parameter	Typical Response
-----------	------------------

DISABLE: Waveform between sequences starts from ENABLE zero-crossing

ENABLE: Waveform continues from the previous waveform's ending angle

Example:

LIST:PCONT ENABLE

[SOURCE:]LIST:APPLY P1|P2|P3

Apply all sequences of a specified phase to all phases

Parameter	Typical Response
P1, P2, P3: Specify phase 1, phase 2, or phase 3 as the source	

Example:

LIST:APPLY P1

[SOURCE:]LIST:CLEAr P1|P2|P3

Clear all sequences of a specified phase

Parameter	Typical Response
P1, P2, P3: Specify phase 1, phase 2, or phase 3 as the source	

Example:

LIST:CLEAR P1

[SOURCE:]LIST[:SEQUENCE]:ADD [,...,<degree>]

Add a new sequence with default values at the end of the current phase

Parameter	Typical Response

Example:

INST:NSEL

1

LIST:ADD

[SOURCE:]LIST[:SEQUENCE]:DELEte <seq>

Delete a specified sequence by index from the current phase

Parameter	Typical Response
<NR1>, valid range: 1 ~ 100 (but not exceeding the total number of sequences in the current editing phase)	
Example:	
LIST:DEL 1	

[SOURce:]LIST[:SEQuence]:EDIT <seq>[,...,<degree>]

[SOURce:]LIST[:SEQuence]:EDIT?

Specify the index of the sequence currently being edited in the current phase

Parameter	Typical Response
<NR1>, valid range: 1 ~ 100 (but not exceeding the total number of sequences in the current editing phase)	
Example:	
LIST:EDIT 1	

[SOURce:]LIST[:SEQuence]:INSert <seq>[,...,<degree>]

Insert a new sequence with default values before a specified sequence in the current phase

Parameter	Typical Response
<NR1>, valid range: 1 ~ 100 (but not exceeding the total number of sequences in the current editing phase)	
Example:	
LIST:INSERT 2	

[SOURce:]LIST[:SEQuence]:COPY <seq>

Insert a new sequence with the same parameters as the currently edited sequence after a specified sequence in the current phase

Parameter	Typical Response
<NR1>, valid range: 1 ~ 100 (but not exceeding the total number of sequences in the current editing phase)	
Example:	
LIST:COPY 2	

[SOURce:]LIST[:SEQuence]:ALL?

<CycleCount>|<DwellTime>,<Shape>,<CSine_THD>,<CSine_AMP>,<Vac_Start>,<Vac_End>,<Vdc_Start>
,<Vdc_End>,<Freq_Start>,<Freq_End>,<StartAngle>

Query all parameter values of the current sequence in the current phase at once

Parameter	Typical Response
	1,1,SINE,0,100,0,0,0,0,60,60,0
Example:	
LIST:EDIT 1	
LIST:ALL?	

[SOURce:]LIST[:SEQuence]:DWELI <value>|MINimum|MAXimum|DEFault**[SOURce:]LIST[:SEQuence]:DWELI? [MINimum|MAXimum|DEFault]**

Set the duration (time) of this sequence

Parameter	Typical Response
<NR2>0.1~99999999.9 (msec)	1000
Example: Set the duration of this sequence to 1 second	
LIST:DWEL 1000	

[SOURce:]LIST[:SEQuence]:CYCLe <value>|MINimum|MAXimum|DEFault**[SOURce:]LIST[:SEQuence]:CYCLe? [MINimum|MAXimum|DEFault]**

Set the cycle count of this sequence

Parameter	Typical Response
<NR1>1~9999 (cycle)	10
Example: Set the cycle count of this sequence to 10	
LIST:CYCL 10	

[SOURce:]LIST[:SEQuence]:SHAPE A|B|SINE|SQUA|TRIAN|CSIN|DST<01..30>|USR<01..30>**[SOURce:]LIST[:SEQuence]:SHAPE?**

Set the output waveform of this sequence

Parameter	Typical Response
-----------	------------------

SINE: Sine wave, SQUA: Square wave, TRIAN: SINE,SQUA,TRIAN,CSIN,DST<1~30>, Triangle wave, CSIN: Clipped sine wave, DST<1~30>: USR<1~30>,A,B Built-in waveforms (30 sets), USR<1~30>: User-defined waveforms (30 sets), A: Buffer A, B: Buffer B

Example: Set the output waveform of this sequence = Sine wave

LIST:SHAP SINE

[SOURCE:]LIST[:SEQUENCE]:CSIN:TYPE THD|AMP

[SOURCE:]LIST[:SEQUENCE]:CSIN:TYPE?

Set the configuration method of CSIN in this sequence

Parameter	Typical Response
THD: Use THD input to determine the shape of the clipped sine wave	THD AMP
AMP: Use AMP input to determine the shape of the clipped sine wave	
Example: Use THD input to determine the shape of the clipped sine wave	
LIST:CSIN:TYPE THD	

[SOURCE:]LIST[:SEQUENCE]:CSIN:THD <value>|MINimum|MAXimum|DEFAULT

[SOURCE:]LIST[:SEQUENCE]:CSIN:THD? [MINimum|MAXimum|DEFAULT]

Set the THD value for the CSIN waveform in this sequence

Parameter	Typical Response
<NR2>0.0~43.0 (%)	5
Example: Set the desired output voltage to a clipped sine wave with THD = 5%	
LIST:CSIN:THD 5	

[SOURCE:]LIST[:SEQUENCE]:CSIN:AMP <value>|MINimum|MAXimum|DEFAULT

[SOURCE:]LIST[:SEQUENCE]:CSIN:AMP? [MINimum|MAXimum|DEFAULT]

Set the clipped peak percentage (AMP) for the CSIN waveform in this sequence

Parameter	Typical Response
<NR2>0.0~100.0 (%)	
Example: Set the desired output voltage to a clipped sine wave with AMP = 95%	
LIST:CSIN:AMP 95	

[SOURCE:]LIST[:SEQUENCE]:VOLTage:AC:STARt <value>|MINimum|MAXimum|DEFault

[SOURCE:]LIST[:SEQUENCE]:VOLTage:AC:STARt? [MINimum|MAXimum|DEFault]

Set the starting AC voltage value of this sequence

Parameter	Typical Response
<NR2>0.0~350.0 (V)	50
Example: Set the starting AC voltage value of this sequence to 50 V	
LIST:VOLT:AC:STAR 50	

[SOURCE:]LIST[:SEQUENCE]:VOLTage:AC:END <value>|MINimum|MAXimum|DEFault

[SOURCE:]LIST[:SEQUENCE]:VOLTage:AC:END? [MINimum|MAXimum|DEFault]

Set the ending AC voltage value of this sequence

Parameter	Typical Response
<NR2>0.0~350.0 (V)	100
Example: Set the ending AC voltage value of this sequence to 100 V	
LIST:VOLT:AC:END 100	

[SOURCE:]LIST[:SEQUENCE]:VOLTage:DC:STARt <value>|MINimum|MAXimum|DEFault

[SOURCE:]LIST[:SEQUENCE]:VOLTage:DC:STARt? [MINimum|MAXimum|DEFault]

Set the starting DC voltage value of this sequence

Parameter	Typical Response
<NR2>-495.0~495.0 (V)	50
Example: Set the starting DC voltage value of this sequence to 50 V	
LIST:VOLT:DC:STAR 50	

[SOURCE:]LIST[:SEQUENCE]:VOLTage:DC:END <value>|MINimum|MAXimum|DEFault

[SOURCE:]LIST[:SEQUENCE]:VOLTage:DC:END? [MINimum|MAXimum|DEFault]

Set the ending DC voltage value of this sequence

Parameter	Typical Response
<NR2>-495.0~495.0 (V)	100
Example: Set the ending DC voltage value of this sequence to 100 V	
LIST:VOLT:DC:END 100	

[SOURce:]LIST[:SEQUence]:FREQUency:STARt <value>|MINimum|MAXimum|DEFault

[SOURce:]LIST[:SEQUence]:FREQUency:STARt? [MINimum|MAXimum|DEFault]

Set the starting frequency value of this sequence

Parameter	Typical Response
<NR2>15.00~1500.00	50
Example: Set the starting frequency value of this sequence to 50 Hz	
LIST:FREQ:STAR 50	

[SOURce:]LIST[:SEQUence]:FREQUency:END <value>|MINimum|MAXimum|DEFault

[SOURce:]LIST[:SEQUence]:FREQUency:END? [MINimum|MAXimum|DEFault]

Set the ending frequency value of this sequence

Parameter	Typical Response
<NR2>15.00~1500.00	100
Example: Set the ending frequency value of this sequence to 100 Hz	
LIST:FREQ:END 100	

[SOURce:]LIST[:SEQUence]:DEGRee <value>|MINimum|MAXimum|DEFault

[SOURce:]LIST[:SEQUence]:DEGRee? [MINimum|MAXimum|DEFault]

Set the starting angle of this sequence

Parameter	Typical Response
<NR2>0.0~359.9	90
Example: Set the starting angle of this sequence to 90 degrees	
LIST:DEGR 90	

13.13 [SOURce:]STEP Subsystem

[SOURce:]STEP

:TRIG AUTO|MANUAL|EXCITE

:TRIG?

:APPLy P1|P2|P3

:VOLTage

:AC <value>|MINimum|MAXimum|DEFault

:AC? [MINimum|MAXimum|DEFault]

:AC:

:DELTA <value>|MINimum|MAXimum|DEFault

:DELTA? [MINimum|MAXimum|DEFault]

:DC <value>|MINimum|MAXimum|DEFault

:DC? [MINimum|MAXimum|DEFault]

:DC

:DELTA <value>|MINimum|MAXimum|DEFault

:DELTA? [MINimum|MAXimum|DEFault]

:DVOLTage

:AC <value>|MINimum|MAXimum|DEFault

:AC? [MINimum|MAXimum|DEFault]

:DC <value>|MINimum|MAXimum|DEFault

:DC? [MINimum|MAXimum|DEFault]

:FREQuency <value>|MINimum|MAXimum|DEFault

:FREQuency? [MINimum|MAXimum|DEFault]

:FREQuency

:DELTA <value>|MINimum|MAXimum|DEFault

:DELTA? [MINimum|MAXimum|DEFault]

:DFREquency <value>|MINimum|MAXimum|DEFault

:DFREquency? [MINimum|MAXimum|DEFault]

:DWELI <value>|MINimum|MAXimum|DEFault

```

:DWELI? [MINimum|MAXimum|DEFault]

:COUNT|STAIr <value>|MINimum|MAXimum|DEFault

:COUNT|STAIr? [MINimum|MAXimum|DEFault]

:DEGRee|SPHase <value>|MINimum|MAXimum|DEFault

:DEGRee|SPHase? [MINimum|MAXimum|DEFault]

:SHAPE SINE|SQUA|TRIAN|CSIN|DST<01..30>|USR<01..30>

:SHAPE?

:CSIN

:MODE THD|AMP

:MODE?

:THD <value>|MINimum|MAXimum|DEFault

:THD? [MINimum|MAXimum|DEFault]

:AMP <value>|MINimum|MAXimum|DEFault

:AMP? [MINimum|MAXimum|DEFault]

```

[SOURce:]STEP Command Table

Command	Description
[SOURce:]STEP:TRIG AUTO MANUAL EXCITE [SOURce:]STEP:TRIG?	Set the trigger mode
SOURce:] STEP:APPLY P1 P2 P3	Apply all configuration values of the specified phase to all phases.
[SOURce:]STEP:VOLTage:AC <value> MINimum MAXimum [SOURce:]STEP:VOLTage:AC? [MINimum MAXimum]	Set the starting AC voltage for STEP
[SOURce:]STEP:VOLTage:AC:DELTA <value> MINimum MAXimum [SOURce:]STEP:VOLTage:AC:DELTA? [MINimum MAXimum]	Set the RMS value of AC voltage change per step
[SOURce:]STEP:VOLTage:DC <value> MINimum MAXimum [SOURce:]STEP:VOLTage:DC? [MINimum MAXimum]	Set the starting DC voltage for STEP
[SOURce:]STEP:VOLTage:DC:DELTA <value> MINimum MAXimum [SOURce:]STEP:VOLTage:DC:DELTA? [MINimum MAXimum]	Set the DC voltage change per step

[SOURce:]STEP:DVOLTage:AC <value> MINimum MAXimum DEFault [SOURce:]STEP:DVOLTage:AC? [MINimum MAXimum DEFault]	Compatible command for STEP:VOLTage:AC:DELTA
[SOURce:]STEP:DVOLTage:DC <value> MINimum MAXimum DEFault [SOURce:]STEP:DVOLTage:DC? [MINimum MAXimum DEFault]	Compatible command for STEP:VOLTage:DC:DELTA
[SOURce:]STEP:FREQuency <value> MINimum MAXimum [SOURce:]STEP:FREQuency? [MINimum MAXimum]	Set the starting frequency for STEP
[SOURce:]STEP:FREQuency:DELTA <value> MINimum MAXimum [SOURce:]STEP:FREQuency:DELTA? [MINimum MAXimum]	Set the frequency change per step
[SOURce:]STEP:DFREquency <value> MINimum MAXimum DEFault [SOURce:]STEP:DFREquency? [MINimum MAXimum DEFault]	Compatible command for STEP:FREQuency:DELTA
[SOURce:]STEP:DWELl <value> MINimum MAXimum [SOURce:]STEP:DWELl? [MINimum MAXimum]	Set the working time per step
[SOURce:]STEP:COUNT STAir <value> MINimum MAXimum [SOURce:]STEP:COUNT STAir? [MINimum MAXimum]	Set the number of steps to execute
[SOURce:]STEP:DEGRee SPHase <value> MINimum MAXimum [SOURce:]STEP:DEGRee SPHase? [MINimum MAXimum]	Set the starting angle for STEP
[SOURce:]STEP:SHAPE A B SINE SQUA TRIAN CSIN DST<01..30> USR<01..30> [SOURce:]STEP:SHAPE?	Set the output waveform for STEP
[SOURce:]STEP:CSIN:MODE THD AMP [SOURce:]STEP:CSIN:MODE?	Set the configuration method for CSIN waveform in STEP
[SOURce:]STEP:CSIN:THD <value> MINimum MAXimum [SOURce:]STEP:CSIN:THD?	Set the THD value for CSIN waveform in STEP
[SOURce:]STEP:CSIN:AMP <value> MINimum MAXimum [SOURce:]STEP:CSIN:AMP?	Set the AMP value for CSIN waveform in STEP

[SOURce:]STEP:TRIG AUTO|MANUAL|EXCITE

[SOURce:]STEP:TRIG?

Set the trigger mode

Parameter	Typical Response
AUTO: Execute the entire LIST program automatically	AUTO MANUAL EXCITE
MANUAL: Execute the LIST program once manually	
EXCITE: Execute the entire LIST program via external trigger	
Example: Set the trigger mode to AUTO	
STEP:TRIG AUTO	

[SOURce:]STEP:VOLTage:AC <value>|MINimum|MAXimum

[SOURce:]STEP:VOLTage:AC? [MINimum|MAXimum]

Set the starting AC voltage for STEP

Parameter	Typical Response
<NR2> 0.0~350.0	50
Example: Set the starting AC voltage for STEP to 50 V	
STEP:VOLT AC 50	

[SOURce:]STEP:VOLTage:AC:DELTA <value>|MINimum|MAXimum

[SOURce:]STEP:VOLTage:AC:DELTA? [MINimum|MAXimum]

Set the RMS value of AC voltage change per step

Parameter	Typical Response
<NR2> 0.0~350.0	10
Example: Set the RMS value of AC voltage change per step to 10 V	
STEP:VOLT:AC:DELT 10	

[SOURce:]STEP:VOLTage:DC <value>|MINimum|MAXimum

[SOURce:]STEP:VOLTage:DC? [MINimum|MAXimum]

Set the starting DC voltage for STEP

Parameter	Typical Response
<NR2> -495.0~495.0	
Example: Set the starting DC voltage for STEP to 50 V	
STEP:VOLT:DC 50.0	

[SOURce:]STEP:VOLTage:DC:DELTA <value>|MINimum|MAXimum

[SOURce:]STEP:VOLTage:DC:DELTA? [MINimum|MAXimum]

Set the DC voltage change per step

Parameter	Typical Response
<NR2>-495.0~495.0	10
Example: Set the DC voltage change per step to 10 V	
STEP:VOLT:DC:DELT 10.0	

[SOURce:]STEP:DVOLTage:AC <value>|MINimum|MAXimum**[SOURce:]STEP:DVOLTage:AC? [MINimum|MAXimum]**

Additional Description

Parameter	Typical Response
Example:	

[SOURce:]STEP:DVOLTage:DC <value>|MINimum|MAXimum**[SOURce:]STEP:DVOLTage:DC? [MINimum|MAXimum]**

Additional Description

Parameter	Typical Response
Example:	

[SOURce:]STEP:FREQuency <value>|MINimum|MAXimum**[SOURce:]STEP:FREQuency? [MINimum|MAXimum]**

Set the starting frequency for STEP

Parameter	Typical Response
<NR2> 15.00~1500.00 (Hz)	50
Example: Set the starting frequency for STEP to 50 Hz	
STEP:FREQ 50	

[SOURce:]STEP:FREQuency:DELTA <value>|MINimum|MAXimum

[SOURce:]STEP:FREQuency:DELTA? [MINimum|MAXimum]

Set the frequency change per step

Parameter	Typical Response
<NR2> -1500.00~1500.00 (Hz)	10
Example: Set the frequency change per step to 10 Hz	
STEP:FREQ:DELT 10	

[SOURce:]STEP:DFREquency <value>|MINimum|MAXimum

[SOURce:]STEP:DFREquency? [MINimum|MAXimum]

Additional Description

Parameter	Typical Response
Example:	

[SOURce:]STEP:DWELI <value>|MINimum|MAXimum

[SOURce:]STEP:DWELI? [MINimum|MAXimum]

Set the working time per step

Parameter	Typical Response
<NR2>0.1~99999999.9 (msec)	100
Example: Set the working time per step to 100 ms	
STEP:DWEL 100	

[SOURce:]STEP:COUNT|STAIr <value>|MINimum|MAXimum

[SOURce:]STEP:COUNT|STAIr? [MINimum|MAXimum]

Set the number of steps to execute

Parameter	Typical Response
<NR1> 1~9999	5
Example: Set the number of steps to execute to 5	
STEP:STA 5	

[SOURCE:]STEP:DEGREE <value>|MINimum|MAXimum

[SOURCE:]STEP:DEGREE? [MINimum|MAXimum]

Set the starting angle for STEP

Parameter	Typical Response
<NR2> 0.0~359.9	
Example: Set the starting angle for STEP to 90 degrees	
STEP:DEGR 90	

[SOURCE:]STEP:SHAPE A|B|SINE|SQUA|TRIAN|CSIN|DST<01..30>|USR<01..30>

[SOURCE:]STEP:SHAPE?

Set the output waveform for STEP

Parameter	Typical Response
SINE: Sine wave, SQUA: Square wave, TRIAN: Triangle wave, CSIN: Clipped sine wave, DST<1~30>: Built-in waveforms (30 sets), USR<1~30>: User-defined waveforms (30 sets), A: Buffer A, B: Buffer B	SINE,SQUA,TRIAN,CSIN,DST<1~30>,USR<1~30>,A,B
Example: Set the output waveform for STEP to Sine wave	
STEP:SHAP SINE	

[SOURCE:]STEP:CSIN:TYPE THD|AMP

[SOURCE:]STEP:CSIN:TYPE?

Set the configuration method for CSIN

Parameter	Typical Response
THD: Use THD input to determine the shape of the clipped sine wave	
AMP: Use AMP input to determine the shape of the clipped sine wave	
Example: Set the CSIN configuration method to THD	
STEP:CSIN:TYPE THD	

[SOURCE:]STEP:CSIN:THD <value>|MINimum|MAXimum

[SOURCE:]STEP:CSIN:THD?

Set the THD value for CSIN

Parameter	Typical Response
<NR2> 0~43.0 (%)	
Example: Set the THD value of CSIN to 5%	
STEP:CSIN:THD 5	

[SOURce:]STEP:CSIN:AMP <value>|MINimum|MAXimum

[SOURce:]STEP:CSIN:AMP?

Set the clipped peak percentage (AMP) for the CSIN waveform

Parameter	Typical Response
<NR2> 0~100.0 (%)	
Example: Set the AMP value of CSIN to 95%	
STEP:CSIN:AMP 95	

13.14 [SOURce:]PULSE Subsystem

[SOURce:]PULSe

:TRIG AUTO|MANUAL|EXCITE

:TRIG?

MINimum|MAXimum

:{LOOP|COUNT} <value>|MINimum|MAXimum

:REPeat <value>|MINimum|MAXimum

:{REPeat|LOOP|COUNT}? [MINimum|MAXimum]

:VOLTage

:AC <value>|MINimum|MAXimum

:AC? [MINimum|MAXimum]

:DC <value>|MINimum|MAXimum

:DC? [MINimum|MAXimum]

```

:FREQuency <value>|MINimum|MAXimum

:FREQuency? [MINimum|MAXimum]

:DEGRee|SPHase <value>|MINimum|MAXimum

:DEGRee|SPHase? [MINimum|MAXimum]

:DCYClE <value>|MINimum|MAXimum

:DCYClE? [MINimum|MAXimum]

:PERiod <value>|MINimum|MAXimum

:PERiod? [MINimum|MAXimum]

:SHAPE A|B|SINE|SQUA|TRIAN|CSIN|DST<01..30>|USR<01..30>

:SHAPE?

:CSIN:

    :TYPE THD|AMP

    :TYPE?

    THD <value>|MINimum|MAXimum

    :THD?

    :AMP <value>|MINimum|MAXimum

    :AMP?

```

[SOURce:]PULSe Command Table

Command	Description
[SOURce:]PULSe:TRIG AUTO MANUAL EXCITE [SOURce:]PULSe:TRIG?	Set the trigger mode
[SOURce:] PULSe:APPLy P1 P2 P3	Apply all settings of the specified phase to all phases.
[SOURce:]PULSe:REPeat <value> MINimum MAXimum [SOURce:]PULSe:{REPeat LOOP COUNT}? [MINimum MAXimum]	Set the total number of executions for the entire PULSE program
[SOURce:]PULSe:VOLTagE:AC <value> MINimum MAXimum [SOURce:]PULSe:VOLTagE:AC? [MINimum MAXimum]	Set the RMS value of AC voltage for PULSE

[SOURce:]PULSe:VOLTage:DC <value> MINimum MAXimum [SOURce:]PULSe:VOLTage:DC? [MINimum MAXimum]	Set the RMS value of DC voltage for PULSE
[SOURce:]PULSe:FREQUency <value> MINimum MAXimum [SOURce:]PULSe:FREQUency? [MINimum MAXimum]	Set the frequency value for PULSE
[SOURce:]PULSe:DEGRee SPHase <value> MINimum MAXimum [SOURce:]PULSe:DEGRee SPHase? [MINimum MAXimum]	Set the starting angle for PULSE
[SOURce:]PULSe:DCYCLE <value> MINimum MAXimum [SOURce:]PULSe:DCYCLE? [MINimum MAXimum]	Set the duty cycle for the entire PULSE time
[SOURce:]PULSe:PERiod <value> MINimum MAXimum [SOURce:]PULSe:PERiod? [MINimum MAXimum]	Set the total time for the entire PULSE
[SOURce:]PULSe:SHAPE A B SINE SQUA TRIAN CSIN DST<01..30> USR<01..30> [SOURce:]PULSe:SHAPE?	Set the output waveform for PULSE
[SOURce:]PULSe:CSIN:TYPE THD AMP [SOURce:]PULSe:CSIN:TYPE?	Set the configuration method for CSIN in PULSE
[SOURce:]PULSe:CSIN:THD <value> MINimum MAXimum [SOURce:]PULSe:CSIN:THD?	Set the THD value for CSIN
[SOURce:]PULSe:CSIN:AMPLitude <value> MINimum MAXimum [SOURce:]PULSe:CSIN:AMPLitude?	Set the AMP value for CSIN

[SOURce:]PULSe:TRIG AUTO|MANUAL|EXCITE

[SOURce:]PULSe:TRIG?

Set the trigger mode

Parameter	Typical Response
AUTO: Execute the entire LIST program automatically	AUTO MANUAL EXCITE
MANUAL: Execute the LIST program once manually	
EXCITE: Execute the entire LIST program via external trigger	
Example: Set the trigger mode to AUTO	
PULS:TRIG AUTO	

[SOURce:] PULSe:APPLy P1|P2|P3

Apply all configuration settings from the selected phase to all phases.

Parameter	Typical Response
P1, P2, and P3 refer to the specified Phase 1, Phase 2, and Phase 3, respectively.	

Example: Apply all settings of Phase 1 to Phase 2 and Phase 3.

PULS:APPLY P1

[SOURce:]PULSe:REPeat <value>|MINimum|MAXimum

[SOURce:]PULSe:{ REPeat|LOOP|COUNT}? [MINimum|MAXimum]

Set the total number of executions for the entire PULSE program

Parameter	Typical Response
<NR1> 0~99999	5

Example: Set the total number of executions for the entire PULSE program to 5

PULS:REP 5

[SOURce:]PULSe:VOLTage:AC <value>|MINimum|MAXimum

[SOURce:]PULSe:VOLTage:AC? [MINimum|MAXimum]

Set the RMS value of the AC voltage for PULSE

Parameter	Typical Response
<NR2> 0.0~350.0 (V)	100

Example: Set the RMS value of the AC voltage for PULSE to 100 V

PULS:VOLT:AC 100

[SOURce:]PULSe:VOLTage:DC <value>|MINimum|MAXimum

[SOURce:]PULSe:VOLTage:DC? [MINimum|MAXimum]

Set the RMS value of the DC voltage for PULSE

Parameter	Typical Response
<NR2> -495.0~495.0 (V)	

Example: Set the RMS value of the DC voltage for PULSE to 10 V

PULS:VOLT:DC 10

[SOURce:]PULSe:FREQUency <value>|MINimum|MAXimum

[SOURce:]PULSe:FREQUency? [MINimum|MAXimum]

Set the frequency value for PULSE

Parameter	Typical Response
-----------	------------------

<code><NR2> 15.0~1500.0 (Hz)</code>	60
---	----

Example: Set the frequency value for PULSE to 60 Hz

PULS:FREQ 60

[SOURce:]PULSe:DEGRee <value>|MINimum|MAXimum

[SOURce:]PULSe:DEGRee? [MINimum|MAXimum]

Set the starting angle

Parameter	Typical Response
<code><NR2> 0.0~359.9 (degrees)</code>	90
Example: Set the starting angle to 90 degrees	
PULS:DEGR 90	

[SOURce:]PULSe:SPHase <value>|MINimum|MAXimum

[SOURce:]PULSe:SPHase? [MINimum|MAXimum]

Set the output waveform for PULSE

Parameter	Typical Response
SINE: Sine wave, SQUA: Square wave, TRIAN: Triangle wave, CSIN: Clipped sine wave, DST<1~30>: Built-in waveforms (30 sets), USR<1~30>: User-defined waveforms (30 sets), A: Buffer A, B: Buffer B	SINE,SQUA,TRIAN,CSIN,DST<1~30>,USR<1~30>,A,B
Example: Set the output waveform for PULSE to CSIN	
PULS:SPH SINE	

[SOURce:]PULSe:DCYCLE <value>|MINimum|MAXimum

[SOURce:]PULSe:DCYCLE? [MINimum|MAXimum]

Set the duty cycle for the entire PULSE time

Parameter	Typical Response
<code><NR2> 0~100.0 (%)</code>	20
Example: Set the duty cycle for the entire PULSE time to 20%	
PULS:DCYC 20	

[SOURce:]PULSe:PERiod <value>|MINimum|MAXimum

[SOURce:]PULSe:PERiod? [MINimum|MAXimum]

Set the total time for the entire PULSE

Parameter	Typical Response
<NR2> 0.1~99999999.9 (msec)	1000
Example: Set the total time for the entire PULSE to 1 second	
PULS:PER 1000	

[SOURce:]PULSe:SHAPE A|B|SINE|SQUA|TRIAN|CSIN|DST<01..30>|USR<01..30>**[SOURce:]PULSe:SHAPE?**

Set the output waveform for PULSE

Parameter	Typical Response
SINE: Sine wave, SQUA: Square wave, TRIAN: Triangle wave, CSIN: Clipped sine wave, DST<1~30>: Built-in waveforms (30 sets), USR<1~30>: User-defined waveforms (30 sets), A: Buffer A, B: Buffer B	SINE,SQUA,TRIAN,CSIN,DST<1~30>,USR<1~30>,A,B
Example: Set the output waveform for PULSE to Sine wave	
PULS:SHAPE SINE	

[SOURce:]PULSe:CSIN:TYPE THD|AMP**[SOURce:]PULSe:CSIN:TYPE?**

Set the configuration method for CSIN

Parameter	Typical Response
THD: Use THD input to determine the shape of the clipped sine wave	
AMP: Use AMP input to determine the shape of the clipped sine wave	
Example: Set the CSIN configuration method to THD	
PULS:CSIN:TYPE THD	

[SOURce:]PULSe:CSIN:THD <value>|MINimum|MAXimum**[SOURce:]PULSe:CSIN:THD?**

Set the THD value for the output CSIN waveform

Parameter	Typical Response
<NR2> 0~43.0 (%)	<NR2> 0~43.0 (%)

Example: Set the desired THD value for the CSIN waveform to 5%

FUNC:CSIN:THD 5

[SOURce:]PULSe:CSIN:AMP <value>|MINimum|MAXimum

[SOURce:]PULSe:CSIN:AMP?

Set the clipped peak percentage (AMP) for the CSIN output waveform

Parameter	Typical Response
<NR2> 0~100.0 (%)	95

Example: Set the clipped peak percentage for the CSIN output waveform to 95%

PULS:CSIN:AMP 95

13.15 [SOURce:]SYNThesis Subsystem

[SOURce:]SYNThesis

:TRIG AUTO|MANUAL|EXCITE

:TRIG?

:LOOP|COUNT <value>|MINimum|MAXimum

:LOOP|COUNT? [MINimum|MAXimum]

:COMPOse VOLTAGE|PERCENT|VALUE1|PERCENT1| VALUE2|PERCENT2| VALUE3|PERCENT3

:COMPOse?

:FUNDamental

[:VOLTage]

[:AC] <value>|MINimum|MAXimum

[:AC]? [MINimum|MAXimum]

[:FUNDamental]

:FREQUENCY <value>|MINimum|MAXimum

:FREQUENCY? [MINimum|MAXimum]

[[:VOLTage]

[:AC] <value>|MINimum|MAXimum

[:AC]? [MINimum|MAXimum]

:DC <value>|MINimum|MAXimum

:DC? [MINimum|MAXimum]

:DEGRee|SPHase <value>|MINimum|MAXimum

:DEGRee|SPHase? [MINimum|MAXimum]

:{VALue|AMPLitude} <N2 value>,<N3 value>,...<N50 value>

:{VALue|AMPLitude}?

:{VALue|AMPLitude}

:ORDer <order>,<value>

:ORDer? <order>

:PERCent <N2 value>,<N3 value>,...<N50 value>

:PERCent?

:PERCent

:ORDer <order>,<value>

:ORDer? <order>

:PHASe <N2 value>,<N3 value>,...<N50 value>

:PHASe?

:PHASe

:ORDer <order>,<value>

:ORDer? <order>

[SOURce:]SYNThesis Command Table

Command	Description
[SOURce:]SYNThesis:TRIG AUTO MANUAL EXCITE	Set the trigger mode

[SOURce:]SYNThesis:TRIG?	
[SOURce:]SYNThesis:LOOP COUNT <value> MINimum MAXimum [SOURce:]SYNThesis:LOOP COUNT? [MINimum MAXimum]	TBD
[SOURce:]SYNThesis:COMPose VALUE PERCENT VALUE1 PERCENT1 VALUE2 PERCENT2 VALUE3 PERCENT3 [SOURce:]SYNThesis:COMPose?	Set the configuration method for SYNTHESIS
[SOURce:]SYNThesis[:FUNDamental][:VOLTage][:AC] <value> MINimum MAXimum [SOURce:]SYNThesis[:FUNDamental][:VOLTage][:AC]? [MINimum MAXimum]	Set the RMS value of the fundamental waveform for SYNTHESIS
[SOURce:]SYNThesis[:FUNDamental]:FREQuency <value> MINimum MAXimum [SOURce:]SYNThesis[:FUNDamental]:FREQuency? [MINimum MAXimum]	Set the frequency of the fundamental waveform for SYNTHESIS
[SOURce:]SYNThesis[:VOLTage]:DC <value> MINimum MAXimum [SOURce:]SYNThesis[:VOLTage]:DC? [MINimum MAXimum]	Set the DC voltage value for SYNTHESIS
[SOURce:]SYNThesis:DEGRee SPHase <value> MINimum MAXimum [SOURce:]SYNThesis:DEGRee SPHase? [MINimum MAXimum]	Set the starting angle
[SOURce:]SYNThesis:{VALue AMPLitude} <N2 value>,<N3 value>,...<N50 value> [SOURce:]SYNThesis:{VALue AMPLitude}?	Set the magnitude of each harmonic component in SYNTHESIS
[SOURce:]SYNThesis:{VALue } :ORDer <order>,<value> [SOURce:]SYNThesis:{VALue AMPLitude} :ORDer? <order>	Set the magnitude of a specific harmonic component in SYNTHESIS
[SOURce:]SYNThesis:PERCent <N2 value>,<N3 value>,...<N50 value> [SOURce:]SYNThesis:PERCent?	Set the magnitude ratio of each harmonic component to the fundamental waveform in SYNTHESIS
[SOURce:]SYNThesis:PERCent:ORDer <order>,<value> [SOURce:]SYNThesis:PERCent:ORDer? <order>	Set the magnitude ratio of a specific harmonic component to the fundamental waveform in SYNTHESIS
[SOURce:]SYNThesis:PHASe <N2 value>,<N3 value>,...<N50 value> [SOURce:]SYNThesis:PHASe?s	Set the phase angle of each harmonic

	component in SYNTHESIS
[SOURce:]SYNThesis:PHASe:ORDer <order>,<value> [SOURce:]SYNThesis:PHASe:ORDer? <order>	Set the phase angle of a specific harmonic component in SYNTHESIS

[SOURce:]SYNThesis:TRIG AUTO|MANUAL|EXCITE

[SOURce:]SYNThesis:TRIG?

Set the trigger mode

Parameter	Typical Response
AUTO: Execute the entire LIST program automatically	AUTO MANUAL EXCITE
MANUAL: Execute the LIST program once manually	
EXCITE: Execute the entire LIST program via external trigger	
Example: Set the trigger mode to AUTO	
SYNT:TRIG AUTO	

[SOURce:] SYNThesis:APPLy P1|P2|P3

Applies all specified harmonic components of the designated phase to all phases.

Parameter	Typical Response
P1, P2, P3 represent the designated Phase 1, Phase 2, and Phase 3, respectively.	
Example: Apply all harmonic components of Phase 1 to all phases	
SYNT:APPLY P1	

[SOURce:] SYNThesis:CLEAr P1|P2|P3

Clears all specified harmonic components of the designated phase.

Parameter	Typical Response
P1, P2, P3 represent the designated Phase 1, Phase 2, and Phase 3, respectively.	
Example: Clear all harmonic components of Phase 1	
SYNT:CLEAR P1	

**[SOURCE:]SYNTHESIS:COMPose VALUE|PERCENT|VALUE1|PERCENT1| VALUE2|PERCENT2|
VALUE3|PERCENT3**

[SOURCE:]SYNTHESIS:COMPose?

Set the configuration method for SYNTHESIS

Parameter	Typical Response
VALUE: Each harmonic component's magnitude is	VALUE PERCENT
represented by its RMS value	
PERCENT: Each harmonic component's magnitude is	
represented by its percentage relative to the fundamental	
Example: Set the SYNTHESIS configuration method to percentage value	
SYNT:COMP PERCENT	

[SOURCE:]SYNTHESIS[:FUNDamental][:VOLTage][:AC] <value>|MINimum|MAXimum

[SOURCE:]SYNTHESIS[:FUNDamental][:VOLTage][:AC]? [MINimum|MAXimum]

Set the RMS value of the fundamental waveform for SYNTHESIS

Parameter	Typical Response
<NR2> 0~350.0 (Vrms)	100
Example: Set the RMS value of the fundamental waveform for SYNTHESIS to 100 V	
SYNT 100	

[SOURCE:]SYNTHESIS[:FUNDamental]:FREQUENCY <value>|MINimum|MAXimum

[SOURCE:]SYNTHESIS[:FUNDamental]:FREQUENCY? [MINimum|MAXimum]

Set the frequency of the fundamental waveform for SYNTHESIS

Parameter	Typical Response
<NR2> 15.0~1500.0 (Hz)	
Example: Set the frequency of the SYNTHESIS fundamental waveform to 6 Hz	

[SOURCE:]SYNTHESIS[:VOLTage]:DC <value>|MINimum|MAXimum

<NR1> 2 ~ 50 (order), <NR2> 0 ~ 359.9 (degrees)

Example: Set the phase angle of the 3rd harmonic component to 30 degrees

SYNT:PHAS:ORD 3,30

13.16 [SOURce:]INTERHARM Subsystem

[SOURce:]INTERHARmonic

:TRIG AUTO|MANUAL|EXCITE

:TRIG?

:FREQuency

:STARt <value>|MINimum|MAXimum

:STARt? [MINimum|MAXimum]

:END <value>|MINimum|MAXimum

:END? [MINimum|MAXimum]

:LEVel <value>|MINimum|MAXimum

:LEVel? [MINimum|MAXimum]

:DWELI <value>|MINimum|MAXimum

:DWELI? [MINimum|MAXimum]

[SOURce:]INTERHARmonics Command Table

Command	Description
[SOURce:]INTERHARmonic:TRIG AUTO MANUAL EXCITE	Set the trigger mode
[SOURce:]INTERHARmonic:TRIG?	
[SOURce:]INTERHARmonic:FREQuency:STARt <value> MINimum MAXimum	Set the starting frequency for interharmonics

[SOURce:]INTERHARmonic:FREQUency:START? [MINimum MAXimum]	
[SOURce:]INTERHARmonic:FREQUency:END <value> MINimum MAXimum	Set the ending frequency for interharmonics
[SOURce:]INTERHARmonic:FREQUency:END? [MINimum MAXimum]	
[SOURce:]INTERHARmonic:LEVel <value> MINimum MAXimum	Set the magnitude ratio for interharmonics
[SOURce:]INTERHARmonic:LEVel? [MINimum MAXimum]	
[SOURce:]INTERHARmonic:DWELl <value> MINimum MAXimum	Set the working time for interharmonics
[SOURce:]INTERHARmonic:DWELl? [MINimum MAXimum]	

[SOURce:]INTERHARmonic:TRIG AUTO|MANUAL|EXCITE

[SOURce:]INTERHARmonic:TRIG?

Set the trigger mode

Parameter	Typical Response
AUTO: Execute the entire LIST program automatically	AUTO MANUAL EXCITE
MANUAL: Execute the LIST program once manually	
EXCITE: Execute the entire LIST program via external trigger	
Example: Set the trigger mode to AUTO	
INTERHAR:TRIG AUTO	

[SOURce:]INTERHARmonic:FREQUency:STARt <value>|MINimum|MAXimum

[SOURce:]INTERHARmonic:FREQUency:STARt? [MINimum|MAXimum]

Set the starting frequency for interharmonics

Parameter	Typical Response
<NR2> 15.0~1500.0 (Hz)	15
Example: Set the starting frequency for interharmonics to 15 Hz	
INTERHAR:FREQ:STAR 15	

[SOURce:]INTERHARmonic:FREQUency:END <value>|MINimum|MAXimum

[SOURce:]INTERHARmonic:FREQUency:END? [MINimum|MAXimum]

Set the ending frequency for interharmonics

Parameter	Typical Response
<NR2> 15.0~1500.0 (Hz)	1500

Example: Set the ending frequency for interharmonics to 1500 Hz

```
INTERHAR:FREQ:END 1500
```

[SOURce:]INTERHARmonic:LEVel <value>|MINimum|MAXimum

[SOURce:]INTERHARmonic:LEVel? [MINimum|MAXimum]

Set the magnitude ratio of interharmonics to the fundamental waveform

Parameter	Typical Response
<NR2> 0.0~100.0 (%)	10

Example: Set the magnitude ratio of interharmonics to the fundamental waveform to 10%

```
INTERHAR:LEV 10
```

[SOURce:]INTERHARmonic:DWELI <value>|MINimum|MAXimum

[SOURce:]INTERHARmonic:DWELI? [MINimum|MAXimum]

Set the working time for interharmonics

Parameter	Typical Response
<NR2> 0.0~99999.99 (sec)	10

Example: Set the working time for interharmonics to 10 seconds

```
INTERHAR:DWEL 10
```

13.17 [SOURce:]TRANSient Subsystem

[SOURce:]TRANsient

:TRIG AUTO|MANUAL|EXCITE

:TRIG?

:LOOP <value>|MINimum|MAXimum

:LOOP? [MINimum|MAXimum]

:SYNChronize ON|OFF

:SYNChronize?

:ACTive ENABLE|DISABLE

```

:ACTive?

:COMPosE VOLTAGE|PERCENT

:COMPosE?

:VOLTagE

    :{VALue|AMPLitude} <value>|MINimum|MAXimum

    :{VALue|AMPLitude}? [MINimum|MAXimum]

:PERCent <value>|MINimum|MAXimum

:PERCent? [MINimum|MAXimum]

    :DIRection SURGe|SAG

    :DIRection?

:ANGLe

    :STARt <value>|MINimum|MAXimum

    :STARt? [MINimum|MAXimum]

    :WIDTh <value>|MINimum|MAXimum

    :WIDTh? [MINimum|MAXimum]

:SYMMetry OFF|ON

:SYMMetry?

:CYCLe

    :TOTal <value>|MINimum|MAXimum

    :TOTal? [MINimum|MAXimum]

    :TRANsient <value>|MINimum|MAXimum

    :TRANsient? [MINimum|MAXimum]

```

Command	Description
[SOURce:]TRANsient:TRIG AUTO MANUAL EXCITE	Set the trigger mode
[SOURce:]TRANsient::TRIG?	

[SOURce:]TRANsient:LOOP <value> MINimum MAXimum [SOURce:]TRANsient:LOOP? [MINimum MAXimum]	Set the total number of executions for the entire TRANSIENT program
[SOURce:]TRANsient:SYNChronize ON OFF [SOURce:]TRANsient:SYNChronize?	Set the synchronization state of the transient time
[SOURce:]TRANsient:ACTive ENABLE DISABLE [SOURce:]TRANsient:ACTive?	Set the TRANSIENT state
[SOURce:]TRANsient:COMPose VOLTAGE PERCENT [SOURce:]TRANsient:COMPose?	Set the magnitude configuration method for TRANSIENT
[SOURce:]TRANsient:VOLTagE:{VALue AMPLitude} <value> MINimum MAXimum [SOURce:]TRANsient:{VALue AMPLitude}? [MINimum MAXimum]	Set the RMS value of the transient waveform voltage
[SOURce:]TRANsient:PERCent <value> MINimum MAXimum [SOURce:]TRANsient:PERCent? [MINimum MAXimum]	Set the magnitude ratio of the transient waveform to the fundamental waveform
[SOURce:]TRANsient:PERCent:DIRection SURGe SAG [SOURce:]TRANsient:PERCent:DIRection?	Set the output of the power mode to pulse or notch
[SOURce:]TRANsient:ANGLE:STARt <value> MINimum MAXimum [SOURce:]TRANsient:ANGLE:STARt? [MINimum MAXimum]	Set the starting angle for the transient waveform
[SOURce:]TRANsient:ANGLE:WIDTh <value> MINimum MAXimum [SOURce:]TRANsient:ANGLE:WIDTh? [MINimum MAXimum]	Set the time of the transient waveform (time unit: angle)
[SOURce:]TRANsient:SYMMetry OFF ON [SOURce:]TRANsient:SYMMetry?	Set the symmetry mode for positive and negative half-cycle waveforms
[SOURce:]TRANsient:CYCLe:TOTal <value> MINimum MAXimum [SOURce:]TRANsient:CYCLe:TOTal? [MINimum MAXimum]	Set the total number of work cycle times for the TRANSIENT operation duration
[SOURce:]TRANsient:CYCLe:TRANsient <value> MINimum MAXimum [SOURce:]TRANsient:CYCLe:TRANsient? [MINimum MAXimum]	Set the actual work cycle times during the TRANSIENT operation

[SOURce:]TRANsient:TRIG AUTO|MANUAL|EXCITE

[SOURCE:]TRANSient::TRIG?

Set the trigger mode

Parameter	Typical Response
AUTO: Execute the entire LIST program automatically	AUTO MANUAL EXCITE
MANUAL: Execute the LIST program once manually	
EXCITE: Execute the entire LIST program via external trigger	
Example: Set the trigger mode to AUTO	
TRAN:TRIG AUTO	

[SOURCE:]TRANSient:LOOP <value>|MINimum|MAXimum**[SOURCE:]TRANSient:LOOP? [MINimum|MAXimum]**

Set the total number of executions for the entire TRANSIENT program

Parameter	Typical Response
<NR1>0~99999,0=Continuous	5
Example: Set the total number of executions for the entire TRANSIENT program to 5 times	
TRAN:LOOP 5	

[SOURCE:]TRANSient:SYNChronize ON|OFF**[SOURCE:]TRANSient:SYNChronize?**

Set the synchronization state of the transient time

Parameter	Typical Response
OFF: Each phase's transient time is based on its own set value	OFF ON
ON: The transient time of the second and third phases is synchronized with the first phase	
Example: Set the transient time of the second and third phases to synchronize with the first phase in TRANSIENT mode	
TRAN:SYNC ON	

[SOURCE:]TRANSient:ACTive ENABLE|DISABLE**[SOURCE:]TRANSient:ACTive?**

Set the TRANSIENT state

Parameter	Typical Response
-----------	------------------

ENABLE: Activate the TRANSIENT mode for the phase ENABLE|DISABLE
 DISABLE: Deactivate the TRANSIENT mode for the phase
 Example: Activate the TRANSIENT mode for the phase
 TRAN:ACT ENABLE

[SOURce:]TRANSient:COMPose VOLTAGE|PERCENT

[SOURce:]TRANSient:COMPose?

Set the magnitude configuration method for TRANSIENT

Parameter	Typical Response
VOLTAGE: RMS value of the transient waveform's voltage	VOLTAGE PERCENT
PERCENT: Magnitude ratio of the transient waveform to the fundamental waveform	
Example: Set the magnitude configuration method for TRANSIENT to PERCENT	
TRAN:COMP PERCENT	

[SOURce:]TRANSient:VOLTage:{VALue|AMPLitude} <value>|MINimum|MAXimum

[SOURce:]TRANSient:{VALue|AMPLitude}? [MINimum|MAXimum]

Set the RMS value of the transient waveform voltage

Parameter	Typical Response
<NR2> 0.0~350.0 (Vrms)	100
Example: Set the RMS value of the transient waveform voltage to 100 V	
TRAN:VOLT 100	

[SOURce:]TRANSient:PERCent <value>|MINimum|MAXimum

[SOURce:]TRANSient:PERCent? [MINimum|MAXimum]

Set the magnitude ratio of the transient waveform to the fundamental waveform

Parameter	Typical Response
<NR2> 0.0~100%	10
Example: Set the magnitude ratio of the transient waveform to the fundamental waveform to 10%	
TRAN:PER 10	

[SOURce:]TRANSient:PERCent:DIRection SURGe|SAG

[SOURce:]TRANsient:PERCent:DIRection?

Set the power mode output to surge or sag (only applicable to TRAN:COMP PERCENT)

Parameter	Typical Response
SURGe: Set the power mode to output surge waveform	SURGe SAG
SAG: Set the power mode to output sag waveform	
Example: Set the power mode to output a surge waveform	
TRAN:PERC:DIR SURG	

[SOURce:]TRANsient:ANGLE:STARt <value>|MINimum|MAXimum**[SOURce:]TRANsient:ANGLE:STARt? [MINimum|MAXimum]**

Set the starting angle of the transient waveform

Parameter	Typical Response
<NR2> 0.0~359.9 (degrees)	85
Example: Set the starting angle of the transient waveform to 85 degrees	
TRAN:ANGL:STAR 85	

[SOURce:]TRANsient:ANGLE:WIDTh <value>|MINimum|MAXimum**[SOURce:]TRANsient:ANGLE:WIDTh? [MINimum|MAXimum]**

Set the duration of the transient waveform (time unit: angle)

Parameter	Typical Response
<NR2> 0.0~359.9 (degrees)	10
Example: Set the duration of the transient waveform to 10 degrees	
TRAN:ANGL:WIDT 10	

[SOURce:]TRANsient:SYMMetry OFF|ON**[SOURce:]TRANsient:SYMMetry?**

Set the symmetry mode for positive and negative half-cycle waveforms

Parameter	Typical Response
OFF: Only the positive half-cycle or the negative half-cycle has the transient waveform	OFF ON
ON: Both positive and negative half-cycles have the transient waveform	

Example: Set the symmetry for positive and negative half-cycle waveforms to ON

TRAN:SYMM ON

[SOURce:]TRANSient:CYCLE:TOTal <value>|MINimum|MAXimum

[SOURce:]TRANSient:CYCLE:TOTal? [MINimum|MAXimum]

Set the total number of work cycles for the TRANSIENT operation duration

Parameter	Typical Response
<NR1> 0~99999 (cycles)	100

Example: Set the total number of work cycles for the TRANSIENT operation duration to 100

TRAN:CYCL:TOT 100

[SOURce:]TRANSient:CYCLE:TRANSient <value>|MINimum|MAXimum

[SOURce:]TRANSient:CYCLE:TRANSient? [MINimum|MAXimum]

Set the actual number of work cycles for the TRANSIENT operation

Parameter	Typical Response
<NR1> 0~99999 (cycles)	50

Example: Set the actual number of work cycles for the TRANSIENT operation to 50

TRAN:CYCL:TRAN 50

13.18 SYSTEM|CONFig Subsystem

[SOURce:]SYSTem|CONFigure

:PARAllel

:CONNect DISABLE|ENABLE

:CONNect?

:POSition?

:INHibit DISABLE|ENABLE

:INHibit?

:EXTernal

[.:VREF] OFF|ON

[.:VREF]?
[.:VREF]
:METHod AMPLifier|LEVel
:METHod?
:MONitor OFF|ON
:MONitor?
:OUTPut DISABLE|ENABLE
:OUTPut?
:COUPling AC|DC
:COUPling?
:EXTON DISABLE|ENABLE
:EXTON?
:VOLTage
:SENSe LOCal|REMOte
:SENSe?
:REMOte
:SENSe OFF|ON
:SENSe?
[:MEASure]
:AVERage 1|2|4|8|16|32
:AVERage?
:LIMit
:SET
:VOLTage
:AC <value>|MINimum|MAXimum|DEFault
:AC? [MINimum|MAXimum|DEFault]

:DC

[:PLUS|:UPPer] <value>|MINimum|MAXimum|DEFault

[:PLUS|:UPPer]? [MINimum|MAXimum|DEFault]

:MINus <value>|MINimum|MAXimum|DEFault

:MINus? [MINimum|MAXimum|DEFault]

:FREQuency <value>|MINimum|MAXimum|DEFault

:FREQuency? [MINimum|MAXimum|DEFault]

:PON IDLE|OUTPut

:PON?

:BUZZer <value>|MINimum|MAXimum|DEFault

:BUZZer? [MINimum|MAXimum|DEFault]

:DISPlay

:BRIGhtness BRIGhtest|MEDIum|DIMMest

:BRIGhtness?

:DATE?

:LANGuage JP|ST|CT|EN

:LANGuage?

:GPIB

[:ADDRess] <value>|MINimum|MAXimum|DEFault

[:ADDRess]? [MINimum|MAXimum|DEFault]

:BAUDrate 9600|19200|38400|115200

:BAUDrate?

:LAN

:DHCP ON|OFF

:DHCP?

:IP

[:ADDRess] <IP1>,<IP2>,<IP3>,<IP4>

[:ADDRess]?

:MASK

[:ADDRess] <IP1>,<IP2>,<IP3>,<IP4>

[:ADDRess]?

:GATeway

[:ADDRess] <IP1>,<IP2>,<IP3>,<IP4>

[:ADDRess]?

:FACTory <password>

SYSTem|CONFig Command Table

Command	Description
[SOURce:]SYSTem CONFigure:PARAllel:CONNect DISABLE ENABLE [SOURce:]SYSTem CONFigure:PARAllel:CONNect?	Set whether the parallel operation mode function is enabled or disabled.
[SOURce:]SYSTem CONFigure:PARAllel:POSition?	Query the functional role of the local unit under parallel operation mode: master or slave.
[SOURce:]SYSTem CONFigure:INHibit DISABLE ENABLE [SOURce:]SYSTem CONFigure:INHibit?	Set whether the remote inhibit output function is enabled or disabled.
[SOURce:]SYSTem CONFigure:EXTernal[:VREF] OFF ON [SOURce:]SYSTem CONFigure:EXTernal[:VREF]?	Set whether the external simulation signal function is enabled or disabled
[SOURce:]SYSTem CONFigure:EXTernal[:VREF]:METHod AMPLifier LEVel [SOURce:]SYSTem CONFigure:EXTernal[:VREF]:METHod?	Set the coupling method for the external simulation signal: AC amplifier mode or DC level mode.
[SOURce:]SYSTem CONFigure:EXTernal:MONitor OFF ON [SOURce:]SYSTem CONFigure:EXTernal:MONitor?	Set whether the external voltage/current level mapping

	function is enabled or disabled.
[SOURce:]SYSTem CONFigure:EXTErnal:OUTPut DISABLE ENABLE [SOURce:]SYSTem CONFigure:EXTErnal:OUTPut?	Set whether the remote control output function is enabled or disabled.
[SOURce:]SYSTem CONFigure:COUPLing AC DC [SOURce:]SYSTem CONFigure:COUPLing?	Compatible command for [SOURce:]SYSTem CONFigure:EXTErnal:METhod with different parameters.
[SOURce:]SYSTem CONFigure:EXTON DISABLE ENABLE [SOURce:]SYSTem CONFigure:EXTON?	Compatible command for [SOURce:]SYSTem CONFigure:EXTErnal:OUTPut.
[SOURce:]SYSTem CONFigure:VOLTagE:SENSE LOCAl REMOte [SOURce:]SYSTem CONFigure:VOLTagE:SENSE?	Set the voltage sensing location: local or remote.
[SOURce:]SYSTem CONFigure: REMote:SENSE OFF ON [SOURce:]SYSTem CONFigure: REMote:SENSE?	Compatible command for [SOURce:]SYSTem CONFigure:VOLTagE:SENSE with different parameters: enable or disable remote voltage sensing.
[SOURce:]SYSTem CONFigure[:MEASure]:AVERage 1 2 4 8 16 32 [SOURce:]SYSTem CONFigure[:MEASure]:AVERage?	Set the number of samples for moving average calculation.
[SOURce:]SYSTem CONFigure:LIMit:SET:VOLTagE:AC <value> MINimum MAXimum DEFault [SOURce:]SYSTem CONFigure:LIMit:SET:VOLTagE:AC? [MINimum MAXimum DEFault]	Set the input upper limit for the AC voltage setting in basic output mode; can be queried or configured as upper limit, lower limit, or default value.
[SOURce:]SYSTem CONFigure:LIMit:SET:VOLTagE:DC[:PLUS]: UPPer] <value> MINimum MAXimum DEFault [SOURce:]SYSTem CONFigure:LIMit:SET:VOLTagE:DC[:PLUS]: UPPer]? [MINimum MAXimum DEFault]	Set the input upper limit for the DC voltage setting in basic output mode; can be queried or configured as upper limit, lower limit, or default value.
[SOURce:]SYSTem CONFigure:LIMit:SET:VOLTagE:DC:MINus <value> MINimum MAXimum DEFault [SOURce:]SYSTem CONFigure:LIMit:SET:VOLTagE:DC:MINus? [MINimum MAXimum DEFault]	Set the input lower limit for the DC voltage setting in basic output mode; can be queried or configured as

	upper limit, lower limit, or default value.
[SOURce:]SYSTem CONFigure:LIMit:SET:FREQUency <value> MINimum MAXimum DEFault [SOURce:]SYSTem CONFigure:LIMit:SET:FREQUency? [MINimum MAXimum DEFault]	Set the input upper limit for the waveform frequency setting in basic output mode; can be queried or configured as upper limit, lower limit, or default value.
[SOURce:]SYSTem CONFigure:PON IDLE OUTPut [SOURce:]SYSTem CONFigure:PON?	Set whether the output is enabled immediately upon instrument startup.
[SOURce:]SYSTem CONFigure:BUZZer <value> MINimum MAXimum DEFault [SOURce:]SYSTem CONFigure:BUZZer? [MINimum MAXimum DEFault]	Set the buzzer volume level.
[SOURce:]SYSTem CONFigure:DISPlay:BRIGhtness BRIGhttest MIDDLE DIMMest [SOURce:]SYSTem CONFigure:DISPlay:BRIGhtness?	Set the backlight brightness of the HMI (Human-Machine Interface) screen.
[SOURce:]SYSTem CONFigure:DATE?	Query the current system time of the instrument.
[SOURce:]SYSTem CONFigure:LANGUage JP ST CT EN [SOURce:]SYSTem CONFigure:LANGUage?	Set the language used for the instrument interface display.
[SOURce:]SYSTem CONFigure:GPIB[:ADDRess] <value> MINimum MAXimum DEFault [SOURce:]SYSTem CONFigure:GPIB[:ADDRess]? [MINimum MAXimum DEFault]	Set the GPIB communication interface address number.
[SOURce:]SYSTem CONFigure:BAUDrate 9600 19200 38400 115200 [SOURce:]SYSTem CONFigure:BAUDrate?	Set the baud rate for the UART communication interface.
[SOURce:]SYSTem CONFigure:LAN:DHCP ON OFF [SOURce:]SYSTem CONFigure:LAN:DHCP?	Set whether the network auto-connect function is enabled or disabled.
[SOURce:]SYSTem CONFigure:LAN:IP[:ADDRess] <IP1>,<IP2>,<IP3>,<IP4> [SOURce:]SYSTem CONFigure:LAN:IP[:ADDRess]?	Set the IP address for manual network connection.
[SOURce:]SYSTem CONFigure:LAN:MASK[:ADDRess] <IP1>,<IP2>,<IP3>,<IP4> [SOURce:]SYSTem CONFigure:LAN:MASK[:ADDRess]?	Set the subnet mask address for manual network connection.

[SOURce:]SYSTem CONFigure:LAN:GATeway[:ADDRess] <IP1>,<IP2>,<IP3>,<IP4> [SOURce:]SYSTem CONFigure:LAN:GATeway[:ADDRess]?	Set the gateway address for manual network connection.
[SOURce:]SYSTem CONFigure:FACTory <password>	Enter a password to restore the instrument to factory default settings.

[SOURce:]SYSTem|CONFigure:PARallel:CONNect DISABLE|ENABLE

[SOURce:]SYSTem|CONFigure:PARallel:CONNect?

Set whether the parallel operation mode function is enabled or disabled.

Parameter	Typical Response
DISABLE: Disables the parallel operation mode and exits the parallel state.	ENABLE
ENABLE: Enables the parallel operation mode and waits for connection.	
Example: Disable parallel operation mode.	
SYST:PAR:CONN DISABLE	

[SOURce:]SYSTem|CONFigure:PARallel:POSITION

[SOURce:]SYSTem|CONFigure:PARallel:POSITION?

Query the functional role of the local unit under parallel operation mode: master or slave.

Parameter	Typical Response
	MASTER
Example: Query the local unit's parallel operation role.	
SYST:PAR:POS?	

[SOURce:]SYSTem|CONFigure:INHibit DISABLE|ENABLE

[SOURce:]SYSTem|CONFigure:INHibit?

Set whether the remote inhibit output function is enabled or disabled.

Parameter	Typical Response
DISABLE: Disables the remote inhibit output function.	ENABLE
ENABLE: Enables the remote inhibit output function.	
Example: Disable the remote inhibit output function.	

SYST:INH DISABLE

[SOURce:]SYSTem|CONFigure:EXTErnal[:VREF] OFF|ON

[SOURce:]SYSTem|CONFigure:EXTErnal[:VREF]?

Set whether the external simulation signal function is enabled or disabled.

Parameter	Typical Response
OFF: Disables the external simulation signal function.	OFF
ON: Enables the external simulation signal function.	
Example: Enable the external simulation signal function.	
SYST:EXT ON	

[SOURce:]SYSTem|CONFigure:EXTErnal[:VREF]:METHod AMPLifier|LEVel

[SOURce:]SYSTem|CONFigure:EXTErnal[:VREF]:METHod?

Set the coupling method for the external simulation signal: AC amplifier mode or DC level mode.

Parameter	Typical Response
AMPLifier: Use the AC amplifier mode to control the simulation signal. The gain is calculated based on the voltage setting, and the external simulation signal is amplified.	AMPLIFIER
LEVel: Use the DC level mode to control the simulation signal. The external simulation signal is linearly mapped to the output voltage.	
Example: Set the coupling method for the external simulation signal to DC level mode.	
SYST:EXT:METH LEVEL	

[SOURce:]SYSTem|CONFigure:EXTErnal:MONitor OFF|ON

[SOURce:]SYSTem|CONFigure:EXTErnal:MONitor?

Set whether the external voltage/current level mapping function is enabled or disabled.

Parameter	Typical Response
OFF: Disables the external voltage/current level mapping function.	OFF
ON: Enables the external voltage/current level mapping function.	

Example: Enable the external voltage/current level mapping function.

```
SYST:EXT:MON ON
```

[SOURce:]SYSTem|CONFigure:EXTernal:OUTPut DISABLE|ENABLE

[SOURce:]SYSTem|CONFigure:EXTernal:OUTPut?

Set whether the remote control output function is enabled or disabled.

Parameter	Typical Response
DISABLE: Disables the remote control output function.	DISABLE
ENABLE: Enables the remote control output function.	
Example: Enable the remote control output function.	
SYST:EXT:OUTP ENABLE	

[SOURce:]SYSTem|CONFigure:COUPling AC|DC

[SOURce:]SYSTem|CONFigure:COUPling?

Set the coupling method for the external simulation signal: AC amplifier mode or DC level mode.

Parameter	Typical Response
AC: Use the AC amplifier mode to control the simulation signal. The gain is calculated based on the voltage setting, and the external simulation signal is amplified.	DC
DC: Use the DC level mode to control the simulation signal. The external simulation signal is linearly mapped to the output voltage.	
Example: Set the coupling method for the external simulation signal to AC amplifier mode.	
SYST:COUP AC	

[SOURce:]SYSTem|CONFigure:EXTON DISABLE|ENABLE

[SOURce:]SYSTem|CONFigure:EXTON?

Set whether the remote control output function is enabled or disabled.

Parameter	Typical Response
DISABLE: Disables the remote control output function.	DISABLE
ENABLE: Enables the remote control output function.	

Example: Enable the remote control output function.

```
SYST:EXTON ENABLE
```

[SOURce:]SYSTem|CONFigure:VOLTage:SENSe LOCAL|REMote

[SOURce:]SYSTem|CONFigure:VOLTage:SENSe?

Set the voltage sensing location: local (instrument) or remote (device under test).

Parameter	Typical Response
LOCAL: Sets the voltage sensing point to the instrument's local terminal.	REMOTE
REMote: Sets the voltage sensing point to the remote device under test (DUT).	

Example: Set the voltage sensing point to the instrument's local terminal.

```
SYST:VOLT:SENS LOCAL
```

[SOURce:]SYSTem|CONFigure: REMote:SENSe OFF|ON

[SOURce:]SYSTem|CONFigure: REMote:SENSe?

Set the remote voltage sensing function on or off.

Parameter	Typical Response
OFF: Sets the voltage sensing point to the instrument's local terminal.	OFF
ON: Sets the voltage sensing point to the remote device under test (DUT).	

Example: Set the voltage sensing point to the remote device under test (DUT).

```
SYST:REM:SENS ON
```

[SOURce:]SYSTem|CONFigure[:MEASure]:AVERage 1|2|4|8|16|32

[SOURce:]SYSTem|CONFigure[:MEASure]:AVERage?

Set the number of samples used for moving average calculation.

Parameter	Typical Response
<NR1>, Valid values: 1 2 4 8 16 32	32

Example: Set the moving average sample count to 8.

```
SYST:MEAS:AVER 8
```

[SOURce:]SYSTem|CONFigure:LIMit:SET:VOLTage:AC

[SOURce:]SYSTem|CONFigure:LIMit:SET:VOLTage:AC?

Set the input upper limit for the AC voltage setting in basic output mode.

Parameter	Typical Response
<NR2>, Valid range: 0~350.0V	200

Example: Set the input upper limit for basic mode AC voltage to 100 V.

SYST:LIM:SET:VOLT:AC 100

[SOURce:]SYSTem|CONFigure:LIMit:SET:VOLTage:DC{:PLUS|:UPPer} <value>

[SOURce:]SYSTem|CONFigure:LIMit:SET:VOLTage:DC{:PLUS|:UPPer}?

Set the input upper limit for the DC voltage setting in basic output mode.

Parameter	Typical Response
<NR2>, Valid range: 0~495.0V	100

Example: Set the input upper limit for basic mode DC voltage to 200 V.

SYST:LIM:SET:VOLT:DC 200

[SOURce:]SYSTem|CONFigure:LIMit:SET:VOLTage:DC:MINus <value>

[SOURce:]SYSTem|CONFigure:LIMit:SET:VOLTage:DC:MINus?

Set the input lower limit for the DC voltage setting in basic output mode.

Parameter	Typical Response
<NR2>, Valid range: -495.0~0V	-100

Example: Set the input lower limit for basic mode DC voltage to -100 V.

SYST:LIM:SET:VOLT:DC:MINUS 100

[SOURce:]SYSTem|CONFigure:LIMit:SET:FREQuency

[SOURce:]SYSTem|CONFigure:LIMit:SET:FREQuency?

Set the input upper limit for the waveform frequency setting in basic output mode.

Parameter	Typical Response
-----------	------------------

<NR2>, Valid range: 15.0~150.0V 60

Example: Set the input upper limit for basic mode frequency to 60 Hz.

SYST:LIM:SET:FREQ 60

[SOURCE:]SYSTEM:CONFIGURE:PON IDLE|OUTPUTON

[SOURCE:]SYSTEM:CONFIGURE:PON?

Set whether the instrument outputs automatically upon startup.

Parameter	Typical Response
IDLE: The instrument enters the main screen and stays in standby mode after startup.	IDLE
OUTPUT: The instrument enters the main screen and automatically starts output as soon as possible after startup.	
Example: Set the instrument to output automatically upon startup.	
SYST:PON OUTPUT	

[SOURCE:]SYSTEM:CONFIGURE:BUZZER

[SOURCE:]SYSTEM:CONFIGURE:BUZZER?

Set the buzzer volume level.

Parameter	Typical Response
<NR1>, Valid range: 0~6	5
Example: Set the buzzer volume to 3.	
SYST:BUZZ 3	

[SOURCE:]SYSTEM:CONFIGURE:DISPLAY:BRIGHTNESS BRIGHtest/MIDDLE/DIMMest

[SOURCE:]SYSTEM:CONFIGURE:DISPLAY:BRIGHTNESS?

Set the backlight brightness level of the human-machine interface (HMI) screen.

Parameter	Typical Response
BRIGHTEST: Maximum brightness.	MIDDLE
MIDDLE: Medium brightness.	
DIMMEST: Minimum brightness.	
Example: Set the screen backlight to the brightest level.	

SYST:DISP:BRIG BRIGHTEST

[SOURCE:]SYSTEM|CONFIGURE:DATE?

Set or query the current system time of the instrument.

Parameter	Typical Response
	2025/02/06 20:31:51

Example: Query the current date and time.

SYST:DATE?

[SOURCE:]SYSTEM|CONFIGURE:LANGUAGE JP|ST|CT|EN

[SOURCE:]SYSTEM|CONFIGURE:LANGUAGE?

Set the display language for the instrument interface.

Parameter	Typical Response
JP: Japanese	EN
ST: Traditional Chinese	
CT: Simplified Chinese	
EN: English	

Example: Set the display language to Simplified Chinese.

SYST:LANG CT

[SOURCE:]SYSTEM|CONFIGURE:GPIB:ADDRESS

[SOURCE:]SYSTEM|CONFIGURE:GPIB:ADDRESS?

Set the addressing number for the GPIB communication interface.

Parameter	Typical Response
<NR1>, Valid range: 1~30	8

Example: Set the GPIB address to 10.

SYST:GPIB:ADDR 10

[SOURCE:]SYSTEM|CONFIGURE:BAUDRATE 9600|19200|38400|115200

[SOURCE:]SYSTEM|CONFIGURE:BAUDRATE?

Set the communication baud rate for the UART interface.

Parameter	Typical Response
-----------	------------------

<NR1>, Only specified numerical values are allowed 115200

Example: Set the UART baud rate to 9600.

SYST:BAUDRATE 9600

[SOURCE:]SYSTEM:CONFIGURE:LAN:DHCP ON|OFF

[SOURCE:]SYSTEM:CONFIGURE:LAN:DHCP?

Set whether the network auto-connect (DHCP) function is enabled or disabled.

Parameter	Typical Response
ON: Enables DHCP auto-connect.	ON
OFF: Disables DHCP auto-connect and uses manually entered values for connection.	
Example: Enable network auto-connect.	
SYST:LAN:DHCP ON	

[SOURCE:]SYSTEM:CONFIGURE:LAN:IP[:ADDRESS] <IP1>,<IP2>,<IP3>,<IP4>

[SOURCE:]SYSTEM:CONFIGURE:LAN:IP[:ADDRESS]?

Set the IP address for manual network connection.

Parameter	Typical Response
Four groups of <NR1>, Valid range: 0~255	192,168,0,1
Example: Set the IP address for manual network connection.	
SYST:LAN:IPADDR 192,168,0,1	

[SOURCE:]SYSTEM:CONFIGURE:LAN:MASK[:ADDRESS] <IP1>,<IP2>,<IP3>,<IP4>

[SOURCE:]SYSTEM:CONFIGURE:LAN:MASK[:ADDRESS]?

Set the subnet mask address for manual network connection.

Parameter	Typical Response
Four groups of <NR1>, Valid range: 0~255	255,255,255,0
Example: Set the subnet mask address for manual network connection.	
SYST:LAN:MASK:ADDR 255,255,255,0	

[SOURCE:]SYSTEM:CONFIGURE:LAN:GATeway[:ADDRESS] <IP1>,<IP2>,<IP3>,<IP4>

[SOURce:]SYSTem|CONFigure:LAN:GATeway[:ADDRess]?

Set the gateway address for manual network connection.

Parameter	Typical Response
Four groups of <NR1>, Valid range: 0~255	0,0,0,0
Example: Set the gateway address for manual network connection.	
SYST:LAN:GAT:ADDR 0,0,0,0	

[SOURce:]SYSTem|CONFigure:FACTORY <password>

Enter the password to restore the instrument to factory default settings.

Parameter	Typical Response
Parameter	Typical Response
Parameter Typical Response	
Password is "0000" , the purpose is to prevent accidental operation rather than to ensure security.	
Example: Restore factory default settings.	
SYST:FACT "0000"	

13.19 INFormation Subsystem

INFormation

```

:VERSion
  :APP?
  :DSP?
  :DA1?
  :DA2?
  :DA3?
  :AD1?
  :AD2?
  :AD3?
  :FPGA?
:CONFigurement?
:OPTion

```

```

:OUTPVOLT?
:OUTPFREQ?
:GRID?
:ELOAD?
:SERial?
:MODEL?

```

INFormation Command Table

Command	Description
INFormation:VERSion:APP?	Query the version number of the Host application
INFormation:VERSion:DSP?	Query the version number of the Host DSP
INFormation:VERSion:DA1?	Query the version number of the first-phase DA DSP
INFormation:VERSion:DA2?	Query the version number of the second-phase DA DSP
INFormation:VERSion:DA3?	Query the version number of the third-phase DA DSP
INFormation:VERSion:AD1?	Query the version number of the first-phase AD DSP
INFormation:VERSion:AD2?	Query the version number of the second-phase AD DSP
INFormation:VERSion:AD3?	Query the version number of the third-phase AD DSP
INFormation:VERSion:FPGA?	Query the version number of the Host FPGA
INFormation:CONFiguration?	Query the function combination purchased for this instrument: Power supply, grid simulation, load simulation, or a combination of these
INFormation:OPTion:OUTPVOLT?	Query the output voltage specifications purchased for this instrument
INFormation:OPTion:OUTPFREQ?	Query the output frequency specifications purchased for this instrument
INFormation:OPTion:GRID?	Query the grid simulation function level purchased for this instrument
INFormation:OPTion:ELOAD?	Query the energy load function level purchased for this instrument
INFormation:SERial?	Query the serial number noted at the time of sale for this instrument
INFormation:MODEL?	Query the power capacity specifications purchased for this instrument

INFormation:VERSion:APP?

Query the version number of the Host application

Parameter	Typical Response
-----------	------------------

Example:

INF:VERS:APP?

INFormation:VERSion:DSP?

Query the version number of the Host DSP

Parameter	Typical Response
-----------	------------------

Example:

INF:VERS:DSP?

INFormation:VERSion:DA1?

Query the version number of the first-phase DA DSP

Parameter	Typical Response
-----------	------------------

Example:

INF:VERS:DA1?

INFormation:VERSion:DA2?

Query the version number of the second-phase DA DSP

Parameter	Typical Response
-----------	------------------

Example:

INF:VERS:DA2?

INFormation:VERSion:DA3?

Query the version number of the third-phase DA DSP

Parameter	Typical Response
-----------	------------------

Example:

INF:VERS:DA3?

INFormation:VERSion:AD1?

Query the version number of the first-phase AD DSP

Parameter	Typical Response
-----------	------------------

Example:

INF:VERS:AD1?

INFormation:VERSion:AD2?

Query the version number of the second-phase AD DSP

Parameter	Typical Response
-----------	------------------

Example:

INF:VERS:AD2?

INFormation:VERSion:AD3?

Query the version number of the third-phase AD DSP

Parameter	Typical Response
-----------	------------------

Example:

INF:VERS:AD3?

INFormation:VERSion:FPGA?

Query the version number of the Host FPGA

Parameter	Typical Response
-----------	------------------

Example:

INF:VERS:FPGA?

INFormation:CONFiguration?

Query the function combination purchased for this instrument: Power supply, grid simulation, load simulation, or a combination of these

Parameter	Typical Response
-----------	------------------

Example:

INF:CONF?

INFormation:OPTion: OUTPVOLT?

Query the output voltage specifications purchased for this instrument

Parameter	Typical Response
-----------	------------------

Example:

INF:OPT:OUTPVOLT?

INFormation:OPTion: OUTPFREQ?

Query the output frequency specifications purchased for this instrument

Parameter	Typical Response
-----------	------------------

Example:

INF:OPT:OUTPFREQ?

INFormation:OPTion: GRID?

Query the grid simulation function level purchased for this instrument

Parameter	Typical Response
-----------	------------------

Example:

INF:OPT:GRID?

INFormation:OPTion: ELOAD?

Query the energy load function level purchased for this instrument

Parameter	Typical Response
-----------	------------------

Example:

INF:OPT:ELOAD?

INFormation:SERial?

Query the serial number noted at the time of sale for this instrument

Parameter	Typical Response
-----------	------------------

Example:

INF:SER?

INFormation:MODEL?

Query the power capacity specifications purchased for this instrument

Parameter	Typical Response
-----------	------------------

Example:

INF:MODEL?

13.20 FILE Subsystem

FILE

:INFO? 1|2|3|4|5|6

:SAVE 1|2|3|4|5|6

:LOAD 1|2|3|4|5|6

FILE Command Table

Command	Description
FILE:INFO? 1 2 3 4 5 6	Query the file cell information, including the storage name and storage date
FILE:SAVE 1 2 3 4 5 6	Save the current instrument settings to a specified file cell
FILE:LOAD 1 2 3 4 5 6	Read the data from a specified file cell and apply it to the current instrument settings

FILE:INFO? 1|2|3|4|5|6

Query the file cell information, including the storage name and storage date

Parameter	Typical Response
1 2 3 4 5 6 are the available cell numbers	1, SaveGroup1, 2024/10/31 19:04:04
Example: Query the file name and save date/time of cell 3	
FILE:INFO? 3	

FILE:SAVE 1|2|3|4|5|6

Save the current instrument settings to a specified file cell

Parameter	Typical Response
1 2 3 4 5 6 are the available cell numbers	
Example: Save the current output parameters/configuration/system settings to cell 3	
FILE:SAVE 3	

FILE:LOAD 1|2|3|4|5|6

Read the data from a specified file cell and apply it to the current instrument settings

Parameter	Typical Response
1 2 3 4 5 6 are the available cell numbers	
Example: Read the data from cell 3 and apply it to the current output	
FILE:LOAD 3	

13.21 CALibration Subsystem

CALibration

:INIT

:INIT?

[:SElect]

:LEVel LEVEL1|LEVEL2|LEVEL3

:LEVel?

:ITEM V_OFFSET|V_DC|V_AC|I_OFFSET|I_AC

:ITEM?

:STARt

:MEASure?

:INSTruction?

:PROceed [<value>]

:REPeat [<value>]

:EXIT

CALibration Command Table

Command	Description
CALibration:INIT CALibration:INIT?	Start the calibration mode and query whether calibration mode was successfully entered.
CALibration[:SElect]:LEVEL LEVEL1 LEVEL2 LEVEL3 CALibration[:SElect]:LEVEL?	Select the module layer to be calibrated.
CALibration[:SElect]:ITEM V_OFFSET V_DC V_AC I_OFFSET I_AC CALibration[:SElect]:ITEM?	Select the calibration item.
CALibration:STARt	After selecting the layer and item, start the calibration procedure.

CALibration:MEASure?	Query the measured value of the current calibration procedure.
CALibration:INSTruction?	Query the next operation instruction of the current calibration procedure.
CALibration:PROCeed [<value>]	Instruct the calibration procedure to proceed to the next step, with an option to input parameters from an external DVM (Digital Voltmeter).
CALibration:REPeat [<value>]	Instruct the calibration procedure to repeat the previous step, with an option to input parameters from an external DVM (Digital Voltmeter).
CALibration:EXIT	End the current calibration procedure and exit calibration mode.

CALibration:INIT**CALibration:INIT?**

Start the calibration mode and query whether the module has successfully entered calibration mode.

Parameter	Typical Response
	ACTIVE
Example: Command the module to enter calibration mode and prepare for special output.	
CALibration:INIT	

CALibration[:SElect]:LEVEL LEVEL1|LEVEL2|LEVEL3**CALibration[:SElect]:LEVEL?**

Select the module layer to be calibrated.

Parameter	Typical Response
LEVEL1: Select the first module layer (Phase 1, R phase).	LEVEL1
LEVEL2: Select the second module layer (Phase 2, S phase).	
LEVEL3: Select the third module layer (Phase 3, T phase).	
Example: Select the first module layer (Phase 1) for calibration.	
CALibration:SElect:LEV LEVEL1	

CALibration[:SElect]:ITEM V_OFFSET|V_DC|V_AC|I_OFFSET|I_AC**CALibration[:SElect]:ITEM?**

Select the calibration item.

Parameter	Typical Response
V_OFFSET: Voltage offset.	V_OFFSET
V_DC: DC voltage.	
V_AC: AC voltage.	
I_OFFSET: Current offset.	
I_AC: AC current.	
Example: Select DC voltage as the calibration item.	
CALibration:SElect:ITEM V_DC	

CALibration:START

After selecting the module layer and calibration item, start the calibration procedure.

Parameter	Typical Response
Example: After selecting the module and item, enter the calibration procedure.	
CALibration:SElect:LEV LEVEL1	
CALibration:SElect:ITEM V_DC	
CALibration START	

CALibration:MEASure?

Query the measured value of the current calibration procedure.

Parameter	Typical Response
	1,60,0.212046,0.210923,0,0
Example: Query the calibration measured value.	
CALibration:MEAS?	

CALibration:INSTruction?

Query the next operation instruction of the current calibration procedure.

Parameter	Typical Response
	"Key in the DVM measured Vdc, then press ""Enter""."
Example: Query the next calibration operation instruction.	
CALibration:INST?	

CALibration:PROCeed [<value>]

Instruct the calibration procedure to proceed to the next step, with an option to input an external DVM

(Digital Voltmeter) measurement value.

Parameter	Typical Response
<NR2> No specific valid range	
Example: Send a measured value and command the calibration procedure to proceed to the next step.	
CALibration:PROC 0.001	

CALibration:REPeat [<value>]

Instruct the calibration procedure to repeat the previous step, with an option to input an external DVM

(Digital Voltmeter) measurement value.

Parameter	Typical Response
<NR2> No specific valid range	
Example: Send a measured value and command the calibration procedure to repeat the previous step.	
CALibration:REPeat 0.001	

CALibration:EXIT

End the current calibration procedure and exit calibration mode.

Parameter	Typical Response
Example: Interrupt the current calibration procedure at any time and exit calibration mode, returning to normal operation.	
CALibration:EXIT	

13.22 Overall Command Table

INSTrument Command Table

Command	Description
INSTrument:SElect OUTPUT1 OUTPUT2 OUTPUT3	Use mnemonic to select the current
INSTrument:SElect?	command-controlled output phase

INSTRument:NSElect 1 2 3 INSTRument:NSElect?	Use a number to select the current command-controlled output phase
INSTRument:EDIT EACH ALL INSTRument: EDIT?	Toggle whether the current control phase is for all phases unified editing and querying
INSTRument:COUPlE NONE ALL INSTRument:COUPlE?	Use a compatible command with different parameters for INSTRument:EDIT

[SOURce:] VOLTage Command Table

Command	Description
[SOURce:]VOLTage[:LEVel][:IMMediate][:AMPLitude][:AC] <value> MINimum MAXimum DEFault [SOURce:]VOLTage[:LEVel][:IMMediate][:AMPLitude][:AC]? [MINimum MAXimum DEFault]	Set the real-time AC voltage RMS output value; can be queried or set to the upper/lower limits or default value
[SOURce:]VOLTage[:LEVel][:IMMediate][:AMPLitude][:AC]:PROTect ion <value> MINimum MAXimum DEFault [SOURce:]VOLTage[:LEVel][:IMMediate][:AMPLitude][:AC]:PROTect ion? [MINimum MAXimum DEFault]	Set the output voltage peak protection value; can be queried or set to the upper/lower limits or default value
[SOURce:]VOLTage[:LEVel][:IMMediate][:AMPLitude]:DC <value> MINimum MAXimum DEFault [SOURce:]VOLTage[:LEVel][:IMMediate][:AMPLitude]:DC? [MINimum MAXimum DEFault]	Set the real-time DC voltage output value; can be queried or set to the upper/lower limits or default value
[SOURce:]VOLTage[:LEVel]:LIMit:AC <value> MINimum MAXimum DEFault [SOURce:]VOLTage[:LEVel]:LIMit:AC? [MINimum MAXimum DEFault]	Set the upper limit value for the AC voltage setting Set the upper limit value for the AC voltage setting Set the upper limit value for the AC voltage setting Set the upper limit value for the AC voltage setting
[SOURce:]VOLTage[:LEVel]:LIMit:DC:{UPPer PLUS} <value> MINimum MAXimum DEFault [SOURce:]VOLTage[:LEVel]:LIMit:DC:{UPPer PLUS}? [MINimum MAXimum DEFault]	Set the upper limit value for the DC voltage setting

[SOURce:]VOLTage[:LEVel]:LIMit:DC:MINus <value> MINimum MAXimum DEFault [SOURce:]VOLTage[:LEVel]:LIMit:DC:MINus? [MINimum MAXimum DEFault]	Set the lower limit value for the DC voltage setting
---	--

[SOURce:] CURRent Command Table

Command	Description
[SOURce:]CURRent[:LEVel]:{LIMit PROTection} <value> MINimum MAXimum DEFault [SOURce:]CURRent[:LEVel]: {LIMit PROTection}? [MINimum MAXimum DEFault]	Set the effective value for overcurrent protection output; can be queried or set to the upper/lower limits or default value
[SOURce:]CURRent[:LEVel]:PROTection:DELAy <value> MINimum MAXimum DEFault [SOURce:]CURRent[:LEVel]:PROTection:DELAy? [MINimum MAXimum DEFault]	Set the delay time for overcurrent protection output (in seconds); can be queried or set to the upper/lower limits or default value
[SOURce:]CURRent[:LEVel]:{INRush SURGe}:INTerval <value> MINimum MAXimum DEFault [SOURce:]CURRent[:LEVel]:INRush SURGe:INTerval? [MINimum MAXimum DEFault]	Set the time interval for surge current measurement judgment (in milliseconds); can be queried or set to the upper/lower limits or default value
[SOURce:]CURRent[:LEVel]:{INRush SURGe}:{STARt DELAy} <value> MINimum MAXimum DEFault [SOURce:]CURRent[:LEVel]:INRush SURGe:STARt DELAy? [MINimum MAXimum DEFault]	Set the starting time for surge current measurement judgment (in milliseconds); can be queried or set to the upper/lower limits or default value
[SOURce:]CURRent:CONTRol DISABLE ENABLE [SOURce:]CURRent:CONTRol?	Set the enable/disable function for output current limit
[SOURce:]CURRent:CONTRol:VALue <value> MINimum MAXimum DEFault [SOURce:]CURRent:CONTRol:VALue? [MINimum MAXimum DEFault]	Set the effective value for output current limit; can be queried or set to the upper/lower limits or default value

[SOURce:] FREQUency Command Table

Command	Description
[SOURce:]FREQUency[:CW IMMEDIATE] <value> MINimum MAXimum DEFault [SOURce:]FREQUency[:CW IMMEDIATE]? [MINimum MAXimum DEFault]	Set the real-time output signal frequency; can be queried or set to the upper/lower limits or default value

[SOURce:]FREQUency:LIMit <value> MINimum MAXimum DEFault [SOURce:]FREQUency:LIMit? [MINimum MAXimum DEFault]	Set the upper limit value for the output frequency setting
--	--

[SOURce:] POWer Command Table

Command	Description
[SOURce:]POWer:PROTection <value> MINimum MAXimum DEFault [SOURce:]POWer:PROTection? [MINimum MAXimum DEFault]	Set the output over-power protection value; can be queried or set to the upper/lower limits or default value
[SOURce:]POWer:CONTRol DISABLE ENABLE [SOURce:]POWer:CONTRol?	Set the enable/disable function for output power limit
[SOURce:]POWer:CONTRol:VALue <value> MINimum MAXimum DEFault [SOURce:]POWer:CONTRol:VALue? [MINimum MAXimum DEFault]	Set the output power limit value; can be queried or set to the upper/lower limits or default value

[SOURce:] FUNCTion Command Table

Command	Description
[SOURce:]FUNCTion:SHAPE SINe SQUAre TRIan CSIN DST<01..30> USR<01..30> [SOURce:]FUNCTion:SHAPE?	Set the output waveform for power mode
[SOURce:]FUNCTion[:CSIN]:MODE THD AMP [SOURce:]FUNCTion[:CSIN]:MODE?	When the waveform is set to CSIN, choose the calculation method for the clipped sine wave
[SOURce:]FUNCTion:CSIN:THD <value> MINimum MAXimum [SOURce:]FUNCTion:CSIN:THD? [MINimum MAXimum DEFault]	Set the total harmonic distortion (THD) value for the clipped sine wave in THD mode
[SOURce:]FUNCTion:CSIN:AMP <value> MINimum MAXimum [SOURce:]FUNCTion:CSIN:AMP?	Set the amplitude residual ratio for the clipped sine wave in AMP mode

OUTPut Command Table

Command	Description
OUTPut[:STATe] ON OFF OUTPut[:STATe]?	Enable or disable voltage output in power mode
OUTPut:PROTection:CLEAr	Clear any active protection states
OUTPut:PROTection:STATe?	Query the protection status
OUTPut:PROTection:EVENT?	Query the protection events that have occurred
OUTPut:MODE FIXED LIST PULSE STEP SYNTH INTERHARM TRANSIENT OUTPut:MODE?	Set the output mode in power mode
OUTPut:COUPling AC DC ACDC OUTPut:COUPling?	Set the coupling method for the output voltage in power mode
OUTPut:RELAy OFF ON OUTPut:RELAy?	Set the working mode of the output relay
OUTPut:SLEW:VOLTAge:AC[:ON] <value> MINimum MAXimum OUTPut:SLEW:VOLTAge:AC[:ON]? [MINimum MAXimum DEFault]	Set the slew rate for the AC voltage value in the output
OUTPut:SLEW:VOLTAge:AC:OFF <value> MINimum MAXimum OUTPut:SLEW:VOLTAge:AC:OFF? [MINimum MAXimum DEFault]	Set the slew rate for the AC voltage output when turned off
OUTPut:SLEW:VOLTAge:DC[:ON] <value> MINimum MAXimum OUTPut:SLEW:VOLTAge:DC[:ON]? [MINimum MAXimum DEFault]	Set the slew rate for the DC voltage value in the output
OUTPut:SLEW:VOLTAge:DC:OFF <value> MINimum MAXimum OUTPut:SLEW:VOLTAge:DC:OFF? [MINimum MAXimum DEFault]	To set the slew rate limit for DC voltage output when output off
OUTPut:SLEW:OFF:VOLTAge:DC <value> MINimum MAXimum OUTPut:SLEW:OFF:VOLTAge:DC? [MINimum MAXimum DEFault]	The compatible command for OUTPut:SLEW:VOLTAge:DC:OFF
OUTPut:SLEW:FREQUency <value> MINimum MAXimum OUTPut:SLEW:FREQUency? [MINimum MAXimum DEFault]	Set the slew rate for the frequency value in the output

OUTPut:IMPedance[:STATe] ON OFF OUTPut:IMPedance[:STATe]?	Set the enable/disable function for output impedance
OUTPut:IMPedance:RESistance[:LEVe] <value> MINimum MAXimum OUTPut:IMPedance:RESistance[:LEVe]? [MINimum MAXimum DEFault]	Set the resistance value for the output impedance function
OUTPut:IMPedance:{INDuctance INDuction}[:LEVe] <value> MINimum MAXimum OUTPut:IMPedance:{INDuctance INDuction}[:LEVe]? [MINimum MAXimum DEFault]	Set the inductance value for the output impedance function

TRIGger Command Table

Command	Description
TRIG OFF ON PAUSE CONTINUE UP DOWN TRIG:STATe?	Trigger specific functions in advanced mode Query the current status of specific functions in advanced mode

PHASe Command Table

Command	Description
PHASe:FUNcTION SINGLE THREE SPLIT PHASe:FUNcTION?	Set the phase mode in power mode
PHASe:MODE INDEPEND SAMEFREQ BALANCE PHASe:MODE?	Set the working mode for three-phase output
PHASe:THREE INDEPEND SAMEFREQ BALANCE PHASe:THREE?	Compatible command for PHASe:MODE
PHASe[:THREE]:BALanced PHASE LINE PHASe[:THREE]:BALanced?	Set the AC voltage display in three-phase balanced mode to either phase voltage or line voltage
PHASe[:THREE]:RELOCK DISABLE ENABLE PHASe[:THREE]:RELOCK?	Set the phase angle relock function in three-phase independent mode
PHASe:STARt:ANGLE DEGRee IMMEDIATE PHASe:STARt: ANGLE?	Set the starting angle of the output waveform, either referencing a specified angle or immediately starting with a random angle

PHASe:STARt[:DEGRee] <value> MINimum MAXimum DEFault PHASe:STARt[:DEGRee]? [MINimum MAXimum DEFault]	Set the starting angle of the output waveform
PHASe:ON <value> MINimum MAXimum DEFault PHASe:ON? [MINimum MAXimum DEFault]	Compatible command for PHASe:STARt
PHASe:END:ANGLE DEGRee IMMEDIATE PHASe:END: ANGLE?	Set the ending point of the output waveform, either referencing a specified angle or immediately ending with a random angle
PHASe:END[:DEGRee] <value> MINimum MAXimum DEFault PHASe:END[:DEGRee]? [MINimum MAXimum DEFault]	Set the ending angle of the output waveform
PHASe:OFF <value> MINimum MAXimum DEFault PHASe:OFF? [MINimum MAXimum DEFault]	Compatible command for PHASe:END
PHASe[:ANGLE]:P12 <value> MINimum MAXimum DEFault PHASe[:ANGLE]:P12? [MINimum MAXimum DEFault]	Set the phase difference between $\Phi 1$ and $\Phi 2$
PHASe[:ANGLE]:P13 <value> MINimum MAXimum DEFault PHASe[:ANGLE]:P13? [MINimum MAXimum DEFault]	Set the phase difference between $\Phi 1$ and $\Phi 3$
PHASe:SEQuence POSITIVE NEGATIVE PHASe:SEQuence?	Set the phase sequence in three-phase mode: Positive or Negative sequence

MEASure|FETCh Command Table

Command	Description
MEASure FETCh[:SCALar]:ALL?	Read all measurement values
MEASure FETCh[:SCALar]:CURRent:AC?	Read the RMS value of the AC component of current
MEASure FETCh[:SCALar]:CURRent:DC?	Read the RMS value of the DC component of current
MEASure FETCh[:SCALar]:CURRent[:ACDC]?	Read the RMS value of the current (AC + DC)
MEASure FETCh[:SCALar]:CURRent:AMPLitude:MAXimum?	Read the peak current measurement value
MEASure FETCh[:SCALar]:CURRent:AMPLitude:MAXimum:POSitive?	Read the positive peak current measurement value

MEASure FETCh[:SCALar]:CURRent:AMPLitude:MAXimum: NEGative?	Read the negative peak current measurement value
MEASure FETCh[:SCALar]:CURRent:CREStfactor?	Read the current peak factor measurement value
MEASure FETCh[:SCALar]:CURRent:INRush?	Read the surge current measurement value
MEASure FETCh[:SCALar]:CURRent:HARMonic[:AMPLitude]?	Read the RMS value of each harmonic component
MEASure FETCh[:SCALar]:CURRent:HARMonic:{DISTort PERcent}? <NR1>	Read the percentage value of each harmonic component
MEASure FETCh[:SCALar]:CURRent:HARMonic:PHASe? [<NR1>]	Read the phase angle of each harmonic component
MEASure FETCh[:SCALar]:CURRent:HARMonic:THD?	Read the total harmonic distortion (THD) percentage of current
MEASure FETCh[:SCALar]:FREQuency[:AMPLitude]?	Read the frequency measurement value
MEASure FETCh[:SCALar]:FREQuency:INTERHARmonics? MEASure FETCh[:SCALar]:INTERHARmonics:FREQuency?	Read the interharmonic frequency value
MEASure FETCh[:SCALar]:POWer[:ACDC]:[REAL]?	Read the real power measurement value
MEASure FETCh[:SCALar]:POWer[:ACDC]:APParent?	Read the apparent power measurement value
MEASure FETCh[:SCALar]:POWer[:ACDC]:REACTive?	Read the reactive power measurement value
MEASure FETCh[:SCALar]:POWer[:ACDC]:PFACTOR?	Read the power factor measurement value
MEASure FETCh[:SCALar]:POWer[:ACDC]:TOTal?	Read the total real power
MEASure FETCh[:SCALar]:POWer[:ACDC]:TOTal:APParent?	Read the total apparent power
MEASure FETCh[:SCALar]:POWer:AC:[REAL]?	Read the real power of the AC component
MEASure FETCh[:SCALar]:POWer:AC:APParent?	Read the apparent power of the AC component
MEASure FETCh[:SCALar]:POWer:AC:REACTive?	Read the reactive power of the AC component
MEASure FETCh[:SCALar]:POWer:AC:PFACTOR?	Read the power factor of the AC component

MEASure FETCh[:SCALar]:POWer:AC:TOTal?	Read the total real power of the AC component
MEASure FETCh[:SCALar]:POWer:AC:TOTal:APParent?	Read the total apparent power of the AC component
MEASure FETCh[:SCALar]:POWer:DC:TOTal?	Read the total real power of the DC component
MEASure FETCh[:SCALar]:VOLTage[:ACDC]?	Read the RMS value of the voltage
MEASure FETCh:SCALar]:VOLTage:AC?	Read the RMS value of the AC component of voltage
MEASure FETCh[:SCALar]:VOLTage:DC?	Read the RMS value of the DC component of voltage
MEASure FETCh[:SCALar]:VOLTage:AMPLitude:MAXimum?	Read the peak voltage measurement value
MEASure FETCh[:SCALar]:VOLTage:AMPLitude:MAXimum:POSitive?	Read the positive peak voltage measurement value
MEASure FETCh[:SCALar]:VOLTage:AMPLitude:MAXimum:NEGative?	Read the negative peak voltage measurement value
MEASure FETCh[:SCALar]:VOLTage:LINE:V12?	Read the line voltage V12 RMS value
MEASure FETCh[:SCALar]:VOLTage:LINE:V23?	Read the line voltage V23 RMS value
MEASure FETCh[:SCALar]:VOLTage:LINE:V31?	Read the line voltage V32 RMS value
MEASure FETCh[:SCALar]:VOLTage:HARMonic[:AMPLitude]?	Read the RMS value of each harmonic component
MEASure FETCh[:SCALar]:VOLTage:HARMonic:{DISort PERcent}? <NR1>	Read the percentage value of each harmonic component
MEASure FETCh[:SCALar]:VOLTage:HARMonic:PHASe? [<NR1>]	Read the phase angle of each harmonic component

MEASure FETCh[:SCALar]:VOLTage:HARMonic:THD?	Read the total harmonic distortion (THD) percentage of voltage
MEASure FETCh[:SCALar]:WAVE:CAPTure	Indicate the data captured for refreshing the DSP output waveform
MEASure FETCh[:SCALar]:WAVE:VOLTage:DATA?	Read the voltage waveform
MEASure FETCh[:SCALar]:WAVE:CURREnt:DATA?	Read the current waveform
MEASure FETCh[:SCALar]:WAVE:TIME:SCALE MEASure FETCh[:SCALar]:WAVE:SCALE?	Set the time scale for the waveform Query the time scale of the waveform

[SOURce:] LIST Command Table

Command	Description
[SOURce:]LIST:TRIG AUTO MANUAL EXCITE [SOURce:]LIST:TRIG?	Set the trigger mode for LIST mode
[SOURce:]LIST:BASE TIME CYCLE [SOURce:]LIST:BASE?	Set the time configuration method for the sequence
[SOURce:]LIST:COUNT LOOP <value> MINimum MAXimum DEFAULT [SOURce:]LIST:COUNT LOOP? [MINimum MAXimum DEFAULT]	Set the number of times the entire LIST program runs
[SOURce:]LIST:PCONTinue DISABLE ENABLE [SOURce:]LIST:PCONTinue?	Set whether the phase angle between sequences starts from zero crossing or continues from the end angle of the previous waveform
[SOURce:]LIST:POINTS TOTAL?	Query the total number of sequences currently being edited in the selected phase
[SOURce:]LIST:APPLY P1 P2 P3	Apply all sequences of the specified phase to all phases
[SOURce:]LIST[:SEQUence]:ADD [,...,<degree>]	Add a new sequence with all default values at the end of the current phase

[SOURce:]LIST[:SEQuence]:DELeTe <seq>	Delete a specific sequence number from the current phase
[SOURce:]LIST[:SEQuence]:INSErt <seq>[,...,<degree>]	Insert a new sequence with all default values before a specified sequence in the current phase
[SOURce:]LIST[:SEQuence]:EDIT <seq>[,...,<degree>] [SOURce:]LIST[:SEQuence]:EDIT?	Specify the sequence number being edited in the current phase
[SOURce:]LIST[:SEQuence]:COpy <seq>	Insert a new sequence with the same parameters as the currently edited one after the specified sequence in the current phase
[SOURce:]LIST[:SEQuence]:ALL?	Inquire all parameter values of the currently edited sequence in the current phase at once
[SOURce:]LIST[:SEQuence]:DWELl <value> MINimum MAXimum DEFault [SOURce:]LIST[:SEQuence]:DWELl? [MINimum MAXimum DEFault]	Set the working time for this sequence
[SOURce:]LIST[:SEQuence]:CYCLe <value> MINimum MAXimum DEFault [SOURce:]LIST[:SEQuence]:CYCLe? [MINimum MAXimum DEFault]	Set the working cycle for this sequence
[SOURce:]LIST[:SEQuence]:SHAPE SINE SQUA TRIAN CSIN DST<01..30> USR<01..30> [SOURce:]LIST[:SEQuence]:SHAPE?	Set the output waveform for this sequence
[SOURce:]LIST[:SEQuence]:CSIN:MODE THD AMP [SOURce:]LIST[:SEQuence]:CSIN:MODE?	Set the CSIN configuration method for this sequence
[SOURce:]LIST[:SEQuence]:CSIN:THD <value> MINimum MAXimum DEFault [SOURce:]LIST[:SEQuence]:CSIN:THD? [MINimum MAXimum DEFault]	Set the CSIN THD value for this sequence
[SOURce:]LIST[:SEQuence]:CSIN:AMP <value> MINimum MAXimum DEFault [SOURce:]LIST[:SEQuence]:CSIN:AMP? [MINimum MAXimum DEFault]	Set the CSIN AMP value for this sequence
[SOURce:]LIST[:SEQuence]:VOLTage:AC:STARt <value> MINimum MAXimum DEFault	Set the AC voltage start value for this sequence

[SOURce:]LIST[:SEQuence]:VOLTage:AC:START? [MINimum MAXimum DEFault]	
[SOURce:]LIST[:SEQuence]:VOLTage:AC:END <value> MINimum MAXimum DEFault [SOURce:]LIST[:SEQuence]:VOLTage:AC:END? [MINimum MAXimum DEFault]	Set the AC voltage end value for this sequence
[SOURce:]LIST[:SEQuence]:VOLTage:DC:START <value> MINimum MAXimum DEFault [SOURce:]LIST[:SEQuence]:VOLTage:DC:START? [MINimum MAXimum DEFault]	Set the DC voltage start value for this sequence
[SOURce:]LIST[:SEQuence]:VOLTage:DC:END <value> MINimum MAXimum DEFault [SOURce:]LIST[:SEQuence]:VOLTage:DC:END? [MINimum MAXimum DEFault]	Set the DC voltage end value for this sequence
[SOURce:]LIST[:SEQuence]:FREQuency:START <value> MINimum MAXimum DEFault [SOURce:]LIST[:SEQuence]:FREQuency:START? [MINimum MAXimum DEFault]	Set the frequency start value for this sequence
[SOURce:]LIST[:SEQuence]:FREQuency:END <value> MINimum MAXimum DEFault [SOURce:]LIST[:SEQuence]:FREQuency:END? [MINimum MAXimum DEFault]	Set the frequency end value for this sequence
[SOURce:]LIST[:SEQuence]:DEGRee <value> MINimum MAXimum DEFault [SOURce:]LIST[:SEQuence]:DEGRee? [MINimum MAXimum DEFault]	Set the starting angle for this sequence

[SOURce:] STEP Command Table

Command	Description
[SOURce:]STEP:TRIG AUTO MANUAL EXCITE [SOURce:]STEP:TRIG?	Set the trigger mode
[SOURce:]STEP:LOOP <value> MINimum MAXimum [SOURce:]STEP:LOOP? [MINimum MAXimum]	Set the number of times the entire STEP program runs
[SOURce:]STEP:VOLTage:AC <value> MINimum MAXimum [SOURce:]STEP:VOLTage:AC? [MINimum MAXimum]	Set the starting AC voltage for STEP
[SOURce:]STEP:VOLTage:AC:DELTA <value> MINimum MAXimum [SOURce:]STEP:VOLTage:AC:DELTA? [MINimum MAXimum]	Set the AC voltage RMS change per step
[SOURce:]STEP:VOLTage:DC <value> MINimum MAXimum [SOURce:]STEP:VOLTage:DC? [MINimum MAXimum]	Set the starting DC voltage for STEP

[SOURce:]STEP:VOLTage:DC:DELTA <value> MINimum MAXimum [SOURce:]STEP:VOLTage:DC:DELTA? [MINimum MAXimum]	Set the DC voltage RMS change per step
[SOURce:]STEP:DVOLTage:AC <value> MINimum MAXimum DEFAULT [SOURce:]STEP:DVOLTage:AC? [MINimum MAXimum DEFAULT]	Compatible command for STEP:VOLTage:AC:DELTA
[SOURce:]STEP:DVOLTage:DC <value> MINimum MAXimum DEFAULT [SOURce:]STEP:DVOLTage:DC? [MINimum MAXimum DEFAULT]	Compatible command for STEP:VOLTage:DC:DELTA
[SOURce:]STEP:FREQuency <value> MINimum MAXimum DEFAULT [SOURce:]STEP:FREQuency? [MINimum MAXimum DEFAULT]	Set the starting frequency for STEP
[SOURce:]STEP:FREQuency:DELTA <value> MINimum MAXimum DEFAULT [SOURce:]STEP:FREQuency:DELTA? [MINimum MAXimum DEFAULT]	Set the frequency change value per step
[SOURce:]STEP:DFREquency <value> MINimum MAXimum DEFAULT [SOURce:]STEP:DFREquency? [MINimum MAXimum DEFAULT]	Compatible command for STEP:FREQuency:DELTA.
[SOURce:]STEP:DWELl <value> MINimum MAXimum DEFAULT [SOURce:]STEP:DWELl? [MINimum MAXimum DEFAULT]	Set the working time for each step
[SOURce:]STEP:COUNT STAir <value> MINimum MAXimum DEFAULT [SOURce:]STEP:COUNT STAir? [MINimum MAXimum DEFAULT]	Set the number of steps to be executed
[SOURce:]STEP:DEGRee SPHase <value> MINimum MAXimum DEFAULT [SOURce:]STEP:DEGRee SPHase? [MINimum MAXimum DEFAULT]	Set the starting angle for STEP
[SOURce:]STEP:SHAPE SINE SQUA TRIAN CSIN DST<01..30> USR<01..30> [SOURce:]STEP:SHAPE?	Set the output waveform for STEP
[SOURce:]STEP:CSIN:MODE THD AMP [SOURce:]STEP:CSIN:MODE?	Set the CSIN configuration method
[SOURce:]STEP:CSIN:THD <value> MINimum MAXimum DEFAULT [SOURce:]STEP:CSIN:THD?	Set the CSIN THD value
[SOURce:]STEP:CSIN:AMP <value> MINimum MAXimum DEFAULT [SOURce:]STEP:CSIN:AMP?	Set the CSIN AMP value

[SOURce:] PULSe Command Table

Command	Description
[SOURce:]PULSe:TRIG AUTO MANUAL EXCITE [SOURce:]PULSe:TRIG?	Set the trigger mode
[SOURce:] PULSe:APPLy P1 P2 P3	Apply all settings of the specified phase to all phases.
[SOURce:]PULSe:REPeat <value> MINimum MAXimum [SOURce:]PULSe:{REPeat LOOP COUNT}? [MINimum MAXimum]	Set the total number of executions for the entire PULSE program

[SOURce:]PULSe:VOLTage:AC <value> MINimum MAXimum [SOURce:]PULSe:VOLTage:AC? [MINimum MAXimum]	Set the RMS value of AC voltage for PULSE
[SOURce:]PULSe:VOLTage:DC <value> MINimum MAXimum [SOURce:]PULSe:VOLTage:DC? [MINimum MAXimum]	Set the RMS value of DC voltage for PULSE
[SOURce:]PULSe:FREQUency <value> MINimum MAXimum [SOURce:]PULSe:FREQUency? [MINimum MAXimum]	Set the frequency value for PULSE
[SOURce:]PULSe:DEGRee SPHase <value> MINimum MAXimum [SOURce:]PULSe:DEGRee SPHase? [MINimum MAXimum]	Set the starting angle for PULSE
[SOURce:]PULSe:DCYCLE <value> MINimum MAXimum [SOURce:]PULSe:DCYCLE? [MINimum MAXimum]	Set the duty cycle for the entire PULSE time
[SOURce:]PULSe:PERiod <value> MINimum MAXimum [SOURce:]PULSe:PERiod? [MINimum MAXimum]	Set the total time for the entire PULSE
[SOURce:]PULSe:SHAPE A B SINE SQUA TRIAN CSIN DST<01..30> USR<01..30> [SOURce:]PULSe:SHAPE?	Set the output waveform for PULSE
[SOURce:]PULSe:CSIN:TYPE THD AMP [SOURce:]PULSe:CSIN:TYPE?	Set the configuration method for CSIN in PULSE
[SOURce:]PULSe:CSIN:THD <value> MINimum MAXimum [SOURce:]PULSe:CSIN:THD?	Set the THD value for CSIN
[SOURce:]PULSe:CSIN:AMPLitude <value> MINimum MAXimum [SOURce:]PULSe:CSIN:AMPLitude?	Set the AMP value for CSIN

[SOURce:] SYNThesis Command Table

Command	Description
[SOURce:]SYNThesis:TRIG AUTO MANUAL EXCITE [SOURce:]SYNThesis:TRIG?	Set the trigger mode
[SOURce:]SYNThesis:LOOP COUNT <value> MINimum MAXimum [SOURce:]SYNThesis:LOOP COUNT? [MINimum MAXimum]	TBD
[SOURce:]SYNThesis:COMPOSE VALUE PERCENT VALUE1 PERCENT1 VALUE2 PERCENT2 VALUE3 PERCENT3 [SOURce:]SYNThesis:COMPOSE?	Set the configuration method for SYNTHESIS
[SOURce:]SYNThesis[:FUNDamental][:VOLTage][:AC] <value> MINimum MAXimum [SOURce:]SYNThesis[:FUNDamental][:VOLTage][:AC]? [MINimum MAXimum]	Set the fundamental wave RMS value for SYNTHESIS

[SOURce:]SYNThesis[:FUNDamental]:FREQuency <value> MINimum MAXimum [SOURce:]SYNThesis[:FUNDamental]:FREQuency? [MINimum MAXimum]	Set the frequency of the fundamental wave for SYNTHESIS
[SOURce:]SYNThesis[:VOLTage]:DC <value> MINimum MAXimum [SOURce:]SYNThesis[:VOLTage]:DC? [MINimum MAXimum]	Set the DC voltage value for SYNTHESIS
[SOURce:]SYNThesis:DEGRee SPHase <value> MINimum MAXimum [SOURce:]SYNThesis:DEGRee SPHase? [MINimum MAXimum]	Set the starting angle
[SOURce:]SYNThesis:{VALue AMPLitude} <N2 value>,<N3 value>,...<N50 value> [SOURce:]SYNThesis:{VALue AMPLitude}?	Set the magnitude of each harmonic component in SYNTHESIS
[SOURce:]SYNThesis:{VALue } :ORDer <order>,<value> [SOURce:]SYNThesis:{VALue AMPLitude} :ORDer? <order>	Set the magnitude of a specified harmonic component in SYNTHESIS
[SOURce:]SYNThesis:PERCent <N2 value>,<N3 value>,...<N50 value> [SOURce:]SYNThesis:PERCent?	Set the ratio of each harmonic component to the fundamental wave in SYNTHESIS
[SOURce:]SYNThesis:PERCent:ORDer <order>,<value> [SOURce:]SYNThesis:PERCent:ORDer? <order>	Set the ratio of a specified harmonic component to the fundamental wave in SYNTHESIS
[SOURce:]SYNThesis:PHASe <N2 value>,<N3 value>,...<N50 value> [SOURce:]SYNThesis:PHASe?s	Set the phase angle of each harmonic component in SYNTHESIS
[SOURce:]SYNThesis:PHASe:ORDer <order>,<value> [SOURce:]SYNThesis:PHASe:ORDer? <order>	Set the phase angle of a specified harmonic component in SYNTHESIS

[SOURce:] INTERHARmonic Command Table

Command	Description
[SOURce:]INTERHARmonic:TRIG AUTO MANUAL EXCITE [SOURce:]INTERHARmonic:TRIG?	Set the trigger mode
[SOURce:]INTERHARmonic:FREQuency:START <value> MINimum MAXimum [SOURce:]INTERHARmonic:FREQuency:START? [MINimum MAXimum]	Set the starting frequency of the interharmonic

[SOURce:]INTERHARmonic:FREQUency:END <value> MINimum MAXimum [SOURce:]INTERHARmonic:FREQUency:END? [MINimum MAXimum]	Set the ending frequency of the interharmonic
[SOURce:]INTERHARmonic:LEVel <value> MINimum MAXimum [SOURce:]INTERHARmonic:LEVel? [MINimum MAXimum]	Set the amplitude ratio of the interharmonic
[SOURce:]INTERHARmonic:DWELl <value> MINimum MAXimum [SOURce:]INTERHARmonic:DWELl? [MINimum MAXimum]	Set the operating time of the interharmonic

[SOURce:]TRANSient Command Table

Command	Description
[SOURce:]TRANSient:TRIG AUTO MANUAL EXCITE [SOURce:]TRANSient::TRIG?	Set the trigger mode
[SOURce:]TRANSient:LOOP <value> MINimum MAXimum [SOURce:]TRANSient:LOOP? [MINimum MAXimum]	Set the number of times the entire TRANSIENT program runs
[SOURce:]TRANSient:SYNChronize ON OFF [SOURce:]TRANSient:SYNChronize?	Set the synchronization status of the transient timing
[SOURce:]TRANSient:ACTive ENABLE DISABLE [SOURce:]TRANSient:ACTive?	Set the TRANSIENT state
[SOURce:]TRANSient:COMPose VOLTAGE PERCENT [SOURce:]TRANSient:COMPose?	Set the amplitude configuration method for TRANSIENT
[SOURce:]TRANSient:VOLTagE:{VALue AMPLitude} <value> MINimum MAXimum [SOURce:]TRANSient:{VALue AMPLitude}? [MINimum MAXimum]	Set the RMS voltage of the transient waveform
[SOURce:]TRANSient:PERCent <value> MINimum MAXimum [SOURce:]TRANSient:PERCent? [MINimum MAXimum]	Set the ratio of the transient waveform to the fundamental wave
[SOURce:]TRANSient:PERCent:DIRection SURGe SAG [SOURce:]TRANSient:PERCent:DIRection?	Set the power mode to output swell/sag
[SOURce:]TRANSient:ANGLE:STARt <value> MINimum MAXimum [SOURce:]TRANSient:ANGLE:STARt? [MINimum MAXimum]	Set the starting angle of the transient waveform
[SOURce:]TRANSient:ANGLE:WIDTh <value> MINimum MAXimum [SOURce:]TRANSient:ANGLE:WIDTh? [MINimum MAXimum]	Set the duration of the transient waveform (unit: degrees)

[SOURce:]TRANSient:SYMMetry OFF ON [SOURce:]TRANSient:SYMMetry?	Set the symmetry mode for positive and negative half-cycle waveforms
[SOURce:]TRANSient:CYCLe:TOTal <value> MINimum MAXimum [SOURce:]TRANSient:CYCLe:TOTal? [MINimum MAXimum]	Set the total number of operating cycles during TRANSIENT operation
[SOURce:]TRANSient:CYCLe:TRANSient <value> MINimum MAXimum [SOURce:]TRANSient:CYCLe:TRANSient? [MINimum MAXimum]	Set the actual number of operating cycles during TRANSIENT execution

SYSTEM|CONFig Command Table

Command	Description
[SOURce:]SYSTEM CONFigure:PARAllel:CONNect DISABLE ENABLE [SOURce:]SYSTEM CONFigure:PARAllel:CONNect?	Enable or disable the parallel operation mode function
[SOURce:]SYSTEM CONFigure:POSition?	Query the functional role of the local unit in parallel mode: Master or Follower
[SOURce:]SYSTEM CONFigure:INHibit DISABLE ENABLE [SOURce:]SYSTEM CONFigure:INHibit?	Enable or disable the remote output inhibit function
[SOURce:]SYSTEM CONFigure:EXTernal[:VREF] OFF ON [SOURce:]SYSTEM CONFigure:EXTernal[:VREF]?	Enable or disable the external simulation signal function
[SOURce:]SYSTEM CONFigure:EXTernal[:VREF]:METHod AMPLifier LEVel [SOURce:]SYSTEM CONFigure:EXTernal[:VREF]:METHod?	Set the coupling method for the external simulation signal: AC amplifier mode or DC level mode
[SOURce:]SYSTEM CONFigure:EXTernal:MONitor OFF ON [SOURce:]SYSTEM CONFigure:EXTernal:MONitor?	Enable or disable the external voltage/current level mapping function
[SOURce:]SYSTEM CONFigure:EXTernal:OUTPut DISABLE ENABLE [SOURce:]SYSTEM CONFigure:EXTernal:OUTPut?	Enable or disable the remote control output function

[SOURce:]SYSTem CONFigure:COUPling AC DC [SOURce:]SYSTem CONFigure:COUPling?	Compatible command for using different parameters of [SOURce:]SYSTem CONFigure:EXTErnal[:VREF]:METHo d
[SOURce:]SYSTem CONFigure:EXTON DISABLE ENABLE [SOURce:]SYSTem CONFigure:EXTON?	Compatible command for [SOURce:]SYSTem CONFigure:EXTErnal:OUTPut
[SOURce:]SYSTem CONFigure:VOLTagE:SENSE Local REMOte [SOURce:]SYSTem CONFigure:VOLTagE:SENSE?	Set the voltage sensing location: local (on the instrument) or remote
[SOURce:]SYSTem CONFigure: REMote:SENSE OFF ON [SOURce:]SYSTem CONFigure: REMote:SENSE?	Compatible command for using different parameters of [SOURce:]SYSTem CONFigure:VOLTagE:SENSE: toggle remote voltage sensing
[SOURce:]SYSTem CONFigure[:MEASure]:AVERAge 1 2 4 8 16 32 [SOURce:]SYSTem CONFigure[:MEASure]:AVERAge?	Set the number of samples for moving average calculation
[SOURce:]SYSTem CONFigure:LIMit:SET:VOLTagE:AC <value> MINimum MAXimum DEFault [SOURce:]SYSTem CONFigure:LIMit:SET:VOLTagE:AC? [MINimum MAXimum DEFault]	Set the soft upper limit of the AC voltage setting value in basic output mode; can query or set to upper/lower limit or default
[SOURce:]SYSTem CONFigure:LIMit:SET:VOLTagE:DC[:PLUS]:UPPer <value> MINimum MAXimum DEFault [SOURce:]SYSTem CONFigure:LIMit:SET:VOLTagE:DC[:PLUS]:UPPer]? [MINimum MAXimum DEFault]	Set the soft upper limit of the DC voltage setting value in basic output mode; can query or set to upper/lower limit or default
[SOURce:]SYSTem CONFigure:LIMit:SET:VOLTagE:DC:MINus <value> MINimum MAXimum DEFault [SOURce:]SYSTem CONFigure:LIMit:SET:VOLTagE:DC:MINus? [MINimum MAXimum DEFault]	Set the soft lower limit of the DC voltage setting value in basic output mode; can query or set to upper/lower limit or default
[SOURce:]SYSTem CONFigure:LIMit:SET:FREQUency <value> MINimum MAXimum DEFault [SOURce:]SYSTem CONFigure:LIMit:SET:FREQUency? [MINimum MAXimum DEFault]	Set the soft upper limit of the waveform frequency setting value in basic output mode; can query or set to upper/lower limit or default

[SOURce:]SYSTem CONFigure:PON IDLE OUTPut [SOURce:]SYSTem CONFigure:PON?	Enable or disable the output-on-at-startup function
[SOURce:]SYSTem CONFigure:BUZZer <value> MINimum MAXimum DEFault [SOURce:]SYSTem CONFigure:BUZZer? [MINimum MAXimum DEFault]	Set the buzzer volume
[SOURce:]SYSTem CONFigure:DISPlay:BRIGHtness BRIGHtest MIDDLE DIMMest [SOURce:]SYSTem CONFigure:DISPlay:BRIGHtness?	Set the screen backlight brightness of the user interface
[SOURce:]SYSTem CONFigure:DATE?	Query the current system time of the instrument
[SOURce:]SYSTem CONFigure:LANGUage JP ST CT EN [SOURce:]SYSTem CONFigure:LANGUage?	Set the language used for the instrument interface display
[SOURce:]SYSTem CONFigure:GPIB[:ADDRess] <value> MINimum MAXimum DEFault [SOURce:]SYSTem CONFigure:GPIB[:ADDRess]? [MINimum MAXimum DEFault]	Set the GPIB communication interface address number
[SOURce:]SYSTem CONFigure:BAUDrate 9600 19200 38400 115200 [SOURce:]SYSTem CONFigure:BAUDrate?	Set the baud rate for the UART communication interface
[SOURce:]SYSTem CONFigure:LAN:DHCP ON OFF [SOURce:]SYSTem CONFigure:LAN:DHCP?	Enable or disable the auto-connect function for the network
[SOURce:]SYSTem CONFigure:LAN:IP[:ADDRess] <IP1>,<IP2>,<IP3>,<IP4> [SOURce:]SYSTem CONFigure:LAN:IP[:ADDRess]?	Set the IP address for manual network connection
[SOURce:]SYSTem CONFigure:LAN:MASK[:ADDRess] <IP1>,<IP2>,<IP3>,<IP4> [SOURce:]SYSTem CONFigure:LAN:MASK[:ADDRess]?	Set the subnet mask for manual network connection
[SOURce:]SYSTem CONFigure:LAN:GATeway[:ADDRess] <IP1>,<IP2>,<IP3>,<IP4> [SOURce:]SYSTem CONFigure:LAN:GATeway[:ADDRess]?	Set the gateway address for manual network connection
[SOURce:]SYSTem CONFigure:FACTory <password>	Enter the password to restore factory default settings

INformation Command Table

Command	Description
---------	-------------

INFormation:VERSiOn:APP?	Query the version number of the Host application
INFormation:VERSiOn:DSP?	Query the version number of the Host DSP
INFormation:VERSiOn:DA1?	Query the version number of Phase 1 DA DSP
INFormation:VERSiOn:DA2?	Query the version number of Phase 2 DA DSP
INFormation:VERSiOn:DA3?	Query the version number of Phase 3 DA DSP
INFormation:VERSiOn:AD1?	Query the version number of Phase 1 AD DSP
INFormation:VERSiOn:AD2?	Query the version number of Phase 2 AD DSP
INFormation:VERSiOn:AD3?	Query the version number of Phase 3 AD DSP
INFormation:VERSiOn:FPGA?	Query the version number of the Host FPGA
INFormation:CONFiGuration?	Query the function package purchased for this instrument: Power Source, Grid Simulation, Load Simulation, or a combination thereof
INFormation:OPTiOn:OUTPVOLT?	Query the output voltage specification purchased for this instrument
INFormation:OPTiOn:OUTPFREQ?	Query the output frequency specification purchased for this instrument
INFormation:OPTiOn:GRID?	Query the grid simulation feature level purchased for this instrument
INFormation:OPTiOn:ELOAD?	Query the energy load feature level purchased for this instrument
INFormation:SERiAl?	Query the serial number noted at the time of sale
INFormation:MODEL?	Query the power capacity specification purchased for this instrument

FILE command table

Command	Description
FILE:INFO? 1 2 3 4 5 6	Query the file cell information, including storage name and storage date
FILE:SAVE 1 2 3 4 5 6	Save the current machine settings to the specified cell
FILE:LOAD 1 2 3 4 5 6	Load data from the specified cell and apply it to the current machine settings

CALibration Command Table

Command	Description
CALibration:INIT CALibration:INIT?	Activate the calibration mode and confirm whether it has been successfully entered.
CALibration[:SElect]:LEVEL LEVEL1 LEVEL2 LEVEL3 CALibration[:SElect]:LEVEL?	Select the module layer to be calibrated.
CALibration[:SElect]:ITEM V_OFFSET V_DC V_AC I_OFFSET I_AC CALibration[:SElect]:ITEM?	Select the item to be calibrated.



INFINIPOWER Technology Co., Ltd.

6F.-2, No. 171, Sec. 2, Datong Rd., Xizhi District, New Taipei City 221424, Taiwan

Service Hotline: +886-2-25175881

Email: sales@infinipowertech.com

Website: www.infinipowertech.com

Copyright by INFINIPOWER Technology Co., Ltd. All Rights Reserved.

All other trade names referenced are the properties of their respective companies.