

# RPS – 5000 Model L

## Regenerative AC Electronic Load



Regenerative



Easy Use



Compliance



High Range



Constant Power



High Current



### KEY FEATURES

- Rated Power: 30 kVA – 225 kVA
- Rated Current: Up to 300A (1Ø) / 100A (3Ø)
- Voltage Range: 0–350Vac(±495Vdc); 0–400V(±565Vdc) (optional)
- Frequency: DC, 30–150 Hz
- Crest Factor Range: 1.414–3.000
- Power Factor Range: 0.100–1.000 (lead/lag)
- 35% higher max current vs. competitors
- 20% better cooling efficiency vs. competitors
- Parallel Operation: Scalable for high power
- Flexible Phase Outputs: 1Ø & 3Ø
- Operating Modes: Constant Voltage (available in DC mode), Constant Current, Constant Power, and Constant Resistance (available in both AC and DC modes).
- Harmonic Analysis: Voltage & current analysis up to the 50th harmonic component
- Up to 90% energy regeneration efficiency
- Regulatory Compliance Testing: Supports IEC 61000-3-2/-3-12 standards verification
- Interfaces: USB, LAN, RS-232, GPIB, CAN, and standard I/O connectivity

### Applications:

- EV & Charging: EV chargers, OBC, wallboxes, V2G/V2H/V2X, charging cables
- Renewable & Storage: Solar PV, grid-tied inverters, ESS, MPPT, power optimizers
- Power & Backup: UPS, PDUs, HVDC power, battery discharge testing
- Simulation & Grid: PHIL support, power quality tests, and anti-islanding protection
- Aerospace & Industrial: For converters, connectors, sensors, fuses, and controllers
- 5G & Data Centers: Ideal for server systems and 48V rack power supplies

## Regenerative AC/DC Electronic Load

The RPS-5000 model-L series is a high-performance regenerative AC/DC electronic load designed for demanding power testing applications. It delivers from 30KVA up to 225kVA via a master-slave parallel configuration.

Engineered for energy efficiency, its advanced regenerative technology returns absorbed power to the grid—reducing electricity use and cooling requirements. Ideal for testing ESS, hybrid PV inverters, EVSE, bidirectional on-board chargers (V2L/V2H), and meeting IEC 62040-3 standards for UPS testing, it minimizes thermal waste and overall system costs.

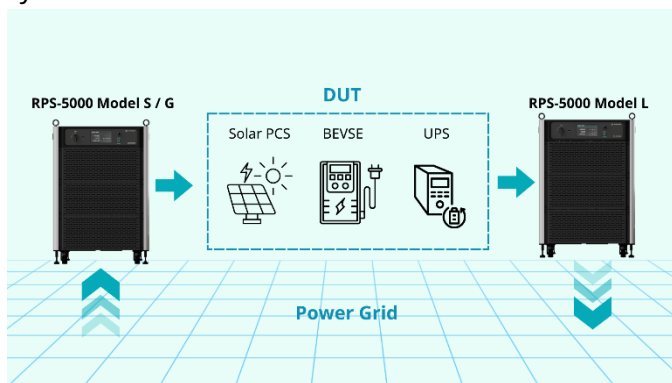

Figure 1: AC Power Supply + Regenerative Load

An intelligent Stand-By function optimizes automated testing by keeping the load active during DUT idle periods and rapidly absorbing power when needed. Supporting multiple test modes (CC, CP, CR) along with advanced simulation functions (rectified mode, phase lead/lag adjustment, half-cycle load for SCR/TRIAC testing), the RPS-5000L is a versatile solution. Additionally, the unique Advance Disturbance feature can be activated across all AC Load modes, allowing users to superimpose programmable harmonic, interharmonic, and combined harmonic disturbance currents, providing

enhanced testing capabilities for complex power conditions.

A 7-inch LCD touchscreen and various communication interfaces (USB, LAN, optional GPIB/CAN) ensure seamless remote control and integration with PowerVUE software and LabVIEW drivers, making it a cutting-edge solution for modern power electronics validation and compliance testing.

## Advanced 4-Quadrant Testing

Unlike traditional two-quadrant AC loads, the RPS-5000L operates seamlessly in all four quadrants, enabling highly precise simulation of inductive and capacitive loads with fully programmable phase shift in both Constant Current (CC) and Constant Apparent Power (CS) modes. This advanced capability allows engineers to emulate complex AC behaviors for more accurate and repeatable testing.

Engineered for advanced AC power validation, the RPS-5000L supports a full suite of linear and nonlinear essential for inverters, UPS systems, and variable-frequency devices. With dedicated CC Rectified and CS Rectified modes, users can fine-tune peak current behavior by adjusting the Crest Factor (CF), ensuring an accurate representation of real-world power system performance.

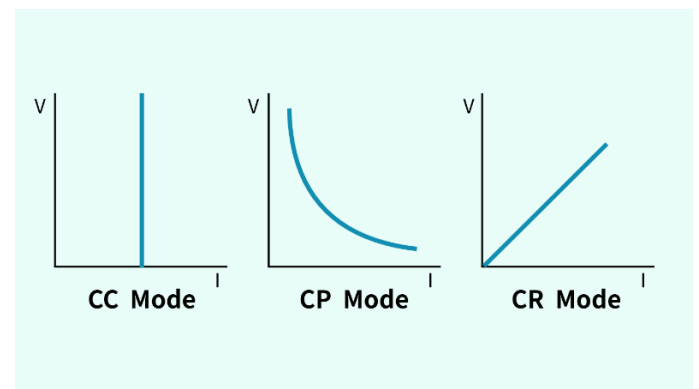

Figure 2: Comprehensive Load Mode

The RPS-5000L Series also enables precise phase angle control, allowing users to simulate leading or lagging power factor conditions accurately. Its high regenerative efficiency not only enhances test flexibility but also reduces energy consumption by returning absorbed power to the grid, making it a sustainable and cost-effective solution for high-power testing applications.

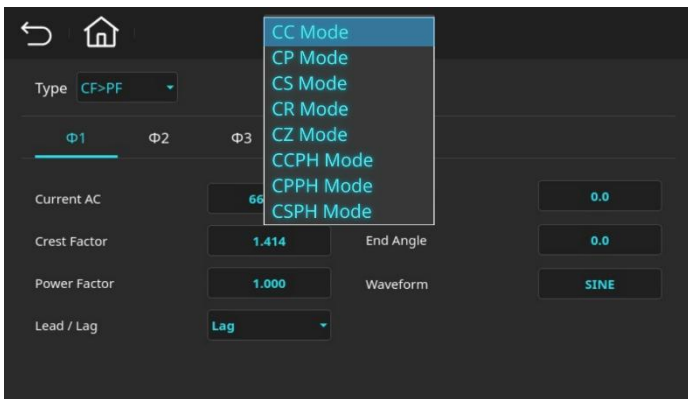

Figure 3: Function Mode Menu

Versatile Operating Modes for Comprehensive Testing

- **AC Modes:** Constant Current (CC), Constant Power (CP), Apparent Power (CS Mode), Constant Resistance (CR), CC+CR, CC/CS Rectifier Mode (Single & Three-Phase), Circuit Impedance Simulation (CZ).

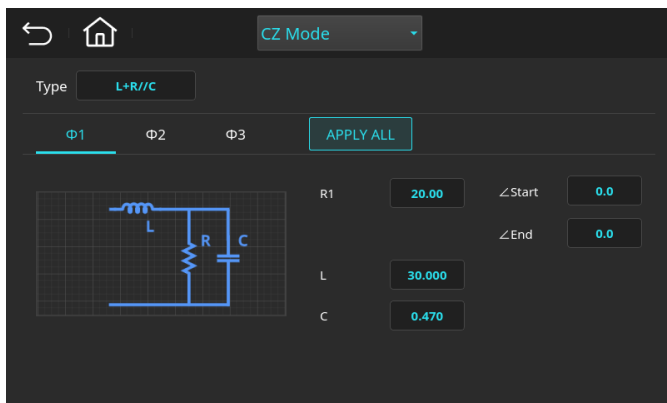

Figure 4: Circuit Impedance Simulation (CZ) Mode

- **DC Modes:** Constant Current (CC), Constant Power (CP), Constant Resistance (CR), CR+CC, Constant Current Dynamic (CCD), Constant Resistance Dynamic (CRD), Battery Test (BATT), Sweep Mode (SWP), Over Current Protection (OCP), Combination Mode (COMB).

Users can adjust phase lead or delay in CC, CP, and CS modes. In CS Mode, apparent power (S) is controlled and measured in volt-amperes (VA).

### High-Efficiency Regenerative AC/DC Load

Built with advanced bidirectional power absorption technology, the RPS-5000L effectively recycles absorbed energy back to the facility's power grid with up to 90% efficiency, significantly reducing operational costs associated with electricity consumption and cooling.

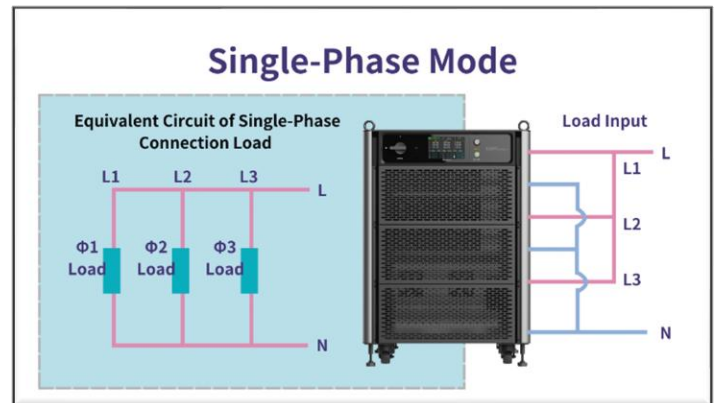

Figure 5: Single-Phase Mode

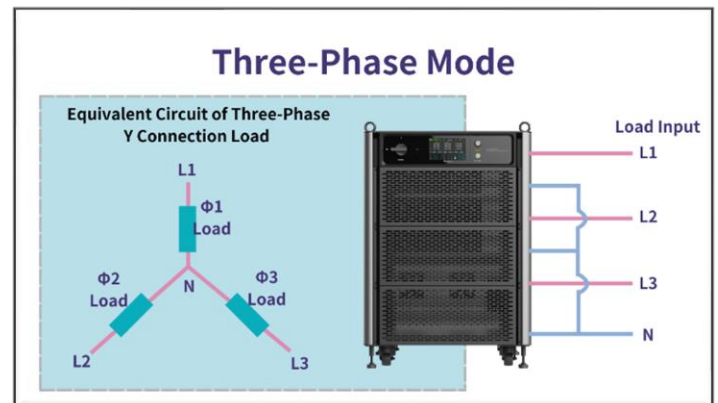

Figure 6: Three-Phase Mode

With versatile single-phase and three-phase operation, the RPS-5000L supports a wide range of power electronics testing scenarios, eliminating the need for multiple independent loads.

### Testing EVSE and Onboard Chargers

The RPS-5000L provides versatile AC/DC load simulation for testing EVSE and onboard chargers (OBC). It supports linear, nonlinear, inductive, capacitive, and resistive load conditions, meeting diverse testing requirements. With flexible AC/DC load modes, it ensures efficient development and validation of EV charging equipment. Additionally, the RPS-5000L enables comprehensive testing of EV impacts on utility grids and V2G technology with bidirectional load simulation. Its regenerative load capability efficiently replicates grid conditions, reducing testing time and energy costs. With AC/DC load functionality, it simulates inductive, capacitive, and resistive loads, ensuring compliance with global standards like IEEE 1547 and UL 1741.

### Intuitive and Clear UI Interface

The RPS-5000 features a 7-inch touchscreen combined with a rotary knob, offering an intuitive user interface that allows users to quickly familiarize themselves with system operations. Multiple display

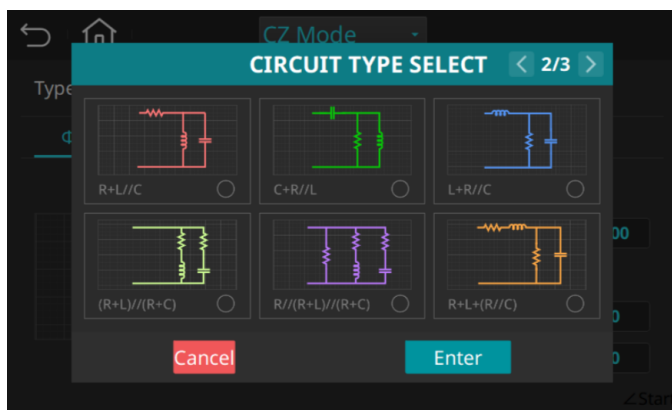

Figure 7: Multi-Mode Load Simulation

modes enable seamless switching between waveform editing, measurement data display, and regulatory parameter settings, ensuring efficient and user-friendly configuration, as shown in Figure 7.

Waveform monitoring and harmonic analysis are essential design tools for optimizing the performance and quality of power products. The RPS-5000 can simultaneously capture three-phase voltage and current waveforms, as shown in Figure 8.

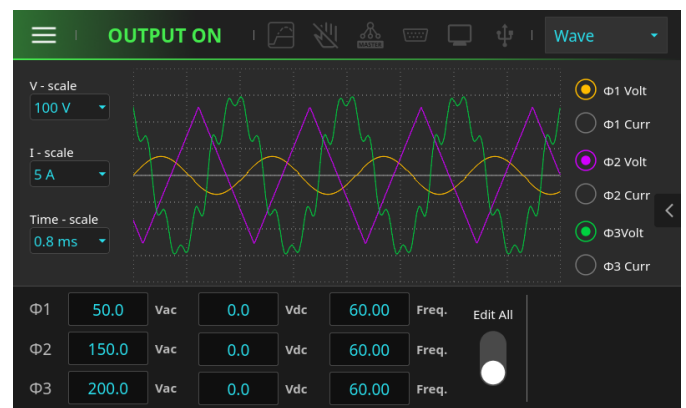

Figure 8: Three-Phase Voltage Waveforms

With its built-in waveform monitoring function, R&D and testing personnel can observe precise voltage and current waveforms in real-time without requiring external instruments.

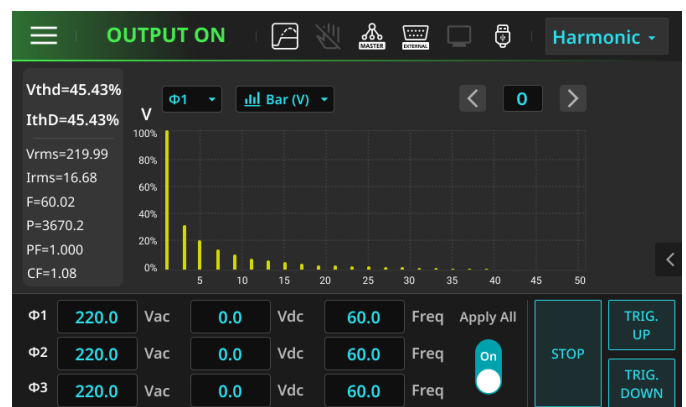

Figure 9: Advanced Harmonic Analysis

The RPS-5000 series features advanced harmonic analysis capabilities, including voltage and current harmonic measurements. It can measure total harmonic distortion (THD) for both voltage and

current, as well as the amplitude and phase difference of individual harmonics relative to the fundamental frequency (as shown in Figure 9). The system supports component analysis up to the 50th harmonic, enabling users to identify specific harmonic components and take appropriate measures to mitigate harmonic interference.

### Regenerative Grid Protection

The RPS-5000L features a robust regenerative design with built-in grid protection mechanisms to ensure safe and reliable operation. It continuously monitors the grid-side AC input for anomalies such as overvoltage, undervoltage, frequency deviations, three-phase imbalance, and excessive current. Upon detection, the system triggers an immediate warning and activates trip protection, preventing potential faults and ensuring compliance with grid safety standards.

### PowerVUE for Remote Control

The RPS-5000 is equipped with PC-based software, PowerVUE, which allows users to operate the device directly from their PC. With PowerVUE, users can easily adjust parameters, monitor

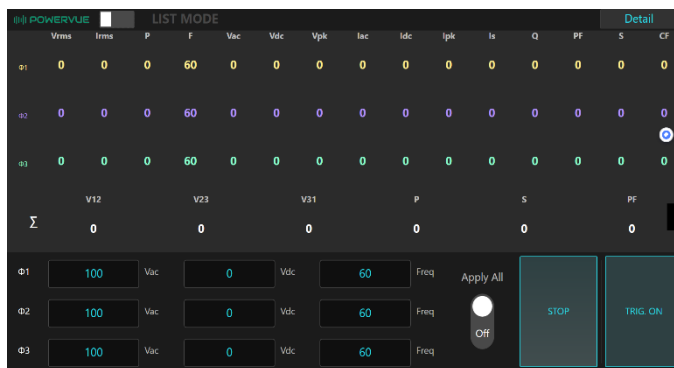

Figure 10: PowerVUE Remote Control Interface performance, quickly create test programs, and generate reports. The software also provides pre-

configured test modes, enabling users to operate the system using defined parameters, ensuring compliance with various international standards (as shown in Figure 10).

### Standard SCPI & LabVIEW driver support

The RPS-5000 supports the SCPI standard protocol, enabling seamless integration into existing test systems via RS-232, GPIB, LAN, or External IO interfaces using compatible SCPI commands without requiring complex modifications. Additionally, the RPS-5000 includes support for LabVIEW, a widely used graphical programming tool for testing, measurement, and control systems. This software development kit allows users to effortlessly integrate, design, and develop various test applications.

### Advanced Simulation Modes

Supports complex testing with programmable waveforms, transient sequences, and harmonic simulations for dynamic power systems. These modes ensure reliable device performance under real-world disturbances.

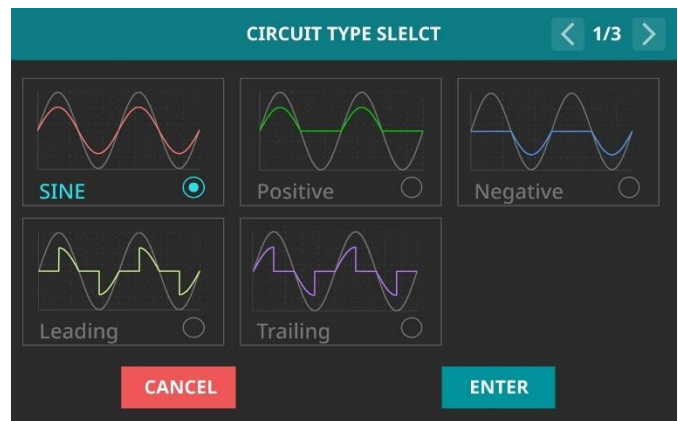

Figure 11: Advanced Mode Configuration

Easily replicate grid conditions, voltage shifts, phase imbalances, and load changes with precision and flexibility. Ideal for compliance, R&D, and stress testing in renewable, EV, and industrial applications.

## Technical Specifications

Item		RPS-5030	RPS-5045	
INPUT	Phase	3Ø3W+PE		
	Voltage	200 - 220 VL-L ± 10% / 380 - 400 VL-L ± 10% / 440 - 480 VL-L ± 10%		
	Frequency	47 - 63Hz		
	Max. Current	95A/phase(200 - 220 VL-L ± 10%) 50A/phase(380 - 400 VL-L ± 10%) 43A/phase(440 - 480 VL-L ± 10%)	143A/phase(200 - 220 VL-L ± 10%) 75A/phase(380 - 400 VL-L ± 10%) 65A/phase(440 - 480 VL-L ± 10%)	
	Power Factor(*1)	0.92(Typical)		
Operating Current	Current(rms)	66.7A(1Ø)/200A(3Ø)	100A(1Ø)/300A(3Ø)	
	Current(peak)	183A(1Ø)/550A(3Ø)	275A(1Ø)/825A(3Ø)	
	Operating Voltage Range	AC Mode : 30 - 350V, Option: 30 - 400V DC Mode : 20 - 495V, Option: 20 - 565V		
Operating Frequency	Range	DC, 30.00 – 150.0 Hz, Option: DC, 30.00 - 400.0 Hz(coming soon)		
<b>AC Load Function</b>				
CC Mode (each phase)	Current	Range	0 - 66.7A	0 - 100A
		Resolution	0.01A	
		Accuracy	± (0.3% of reading + 0.5% F.S) at Current > 3A	
	Crest Factor	Range	1.414 - 3.000	
		Resolution	0.001	
	Power Factor	Range	0.593 - 1.000(type=PF) / 0.202 - 1.000(type=CFPF)	
Resolution		0.001		
CP/CS Mode (each phase)	POWER	Range	0 - 10kW, kVA	0 - 15kW, kVA
		Resolution	1W, VA	
		Accuracy	± (0.3% of reading + 0.3% F.S) at Power > 200W, VA	
	Crest Factor	Resolution	1.414 - 3.000	
		Resolution	0.001	
	Power Factor	Accuracy	0.593 - 1.000(type=PF) / 0.202 - 1.000(type=CFPF)	
Resolution		0.001		
CR Mode (each phase)	Resistance	Range	0.45 - 525Ω	0.3 - 525Ω
		Resolution	0.01Ω	
		Accuracy	± (0.3% of reading + 0.5% F.S) at Current > 3A	
CZ Mode (each phase)	Impedance	R1 Range	0.01 - 1000.00Ω	
		R1 Resolution	0.01Ω	
		R2 Range	0.01 - 1000.00Ω	
		R2 Resolution	0.01Ω	
		R3 Range	0.01 - 1000.00Ω	
		R3 Resolution	0.01Ω	
		C Range	0 - 100.000mF	
		C Resolution	0.001mF	
L Range	0 - 1000.000mH			
	L Resolution	0.001mH		
CC Phase Lead/Lag Mode (each phase)	Power	Range	0 - 66.7A	0 - 100A
		Resolution	0.01A	
		Accuracy	± (0.3% of reading + 0.5% F.S) at Current > 3A	
	Phase	Range	-90.0deg ~ +90.0deg(Current source mode: +90.1deg ~ +180deg & -90.1deg ~ -180deg)	
		Resolution	0.1deg	
CP/CS Phase Lead/Lag Mode (each phase)	Power	Range	0 - 10kW, kVA	0 - 15kW, kVA
		Resolution	1W, VA	
		Accuracy	± (0.3% of reading + 0.3% F.S) at Power > 200W, VA	
	Phase	Range	-90.0deg ~ +90.0deg(Current source mode: +90.1deg ~ +180deg & -90.1deg ~ -180deg)	
		Resolution	0.1deg	
Range	± 1% F.S.			
<b>DC Load Function(coming soon)</b>				
CC Mode (each phase)	Current	Range	0 - 66.7A	0 - 100A
		Resolution	0.01A	
		Accuracy	± (0.3% of reading + 0.5% F.S) at Current > 3A	
		Slew rate	0 - 4000A/msec	

## Technical Specifications

Item		RPS-5030		RPS-5045		
CV Mode (each phase)	Voltage	Range	0 - 495V			
		Resolution	0.01V			
		Accuracy	± (0.1% of reading + 0.2% F.S) at Voltage > 5V			
CP Mode (each phase)	Power	Range	0 - 10kW	0 - 15kW		
		Resolution	1W			
		Accuracy	± (0.3% of reading + 0.3% F.S) at Power > 200W			
CR Mode (each phase)	Resistance	Range	0.5 - 1000Ω			
		Resolution	0.01Ω			
		Accuracy	Convert to current value ± (0.3% of reading + 0.5% F.S) at Current > 3A			
Advanced Mode	Mode(each phase)		CCD, CRD			
MEASUREMENT	Voltage (AC)	Range	1Ø / 3Ø	0 - 350V (Phase), 0 - 606V (Line), Option: 0 - 400V(Phase), 0 - 692V (Line)		
		Resolution / Accuracy	0.01V / ± (0.1% of reading + 0.2% F.S) at Voltage > 5V			
	Voltage (DC)	Range	1Ø / 3Ø	0 - 495V, Option: 0 - 565V		
		Resolution / Accuracy	0.01V / ± (0.1% of reading + 0.2% F.S) at Voltage > 5V			
	Current (AC,DC)	Range	1Ø	0.00 - 200.00A	0.00 - 300.00A	
			3Ø	0.00 - 66.70A	0.00 - 100.00A	
		Resolution / Accuracy	0.01A / ± (0.4% of reading + 0.3% F.S)			
	Peak Current	Range	1Ø	0.0 - 550.0Apk	0.0 - 825.0Apk	
			3Ø	0.0 - 183.0Apk	0.0 - 275.0Apk	
		Resolution / Accuracy	0.1A / ± (0.4% of reading + 0.6% F.S)			
	Power (AC,DC)	Range	1Ø	0.0W - 30kW	0.0W - 45kW	
			3Ø	0.0W - 10kW	0.0W - 15kW	
		Resolution / Accuracy	0.1W at 0.0 - 9999.9W / 1W at Power ≥10000W / ± (0.4% of reading + 0.4% F.S)			
	Power Apparent (VA)	Range	1Ø	0VA - 30kVA	0VA - 45kVA	
			3Ø	0VA - 10kVA	0VA - 15kVA	
		Resolution / Accuracy	0.1VA at 0.0W - 9999.9VA / 1VA at Power ≥10000VA / V×A, Calculated value			
	Power Factor	Range	0 - 1.000			
Resolution / Accuracy		0.001 / W / VA, Calculated and displayed to three significant digits				
Crest Factor	Range	0 - 10.00				
	Resolution / Accuracy	0.01 / Ap / A, Calculated and displayed to two significant digits				
GENERAL	Operation Key Feature		Rotary Knob, Output Button			
	Count		0 - 99999, 0 = Continuous			
	External Interface		AC-ON / Remote-Inhibit / Fault-Out / Ext-ONOFF / Ext-I / VMON / IMON			
	Volume Setting		Range: 0 - 6 ; 0 = OFF, 1 is softest volume, 3 is loudest volume (Alarm, Rotary Knob)			
	Graphic Display		7" LCD (16:9 touch screen) / Contrast 3 Levels 1 - 3			
	Interface		USB, RS232, LAN, External I/O(DB25),GPIB Option: CAN Bus			
	Protection Circuits		OCP, OVP, OPP, OTP, SHORT, FAN			
	Efficiency(*2)		>90%			
	Dimension(H x W x D)(with casters)		1004 x 704 x 910 mm / 39.53 x 27.72 x 35.83 inch			
	Weight		550kg / 1212.542 lbs			
ENVIRONMENTAL	Cooling		Variable speed fan cooled, front intake, rear exhaust			
	Operating Temperature		0 to 40°C (32°F to 104°F)			
	Storage Temperature		-20 to 70°C (-4°F to 158°F)			
	Altitude		2000m (6500 feet)			
	Operating Humidity(*3)		0% to 95% RAH			
REGULATORY COMPLIANCE	Safety		Low Voltage Directive 2014/35/EU, EN 61010-1:2010 + A1:2019			
	EMC		CE marked for EMC Directive 2014/30/EU per EN 61326-1:2021 Class A			
	CE Mark LVD Categories		Installation Overvoltage Category: II; Pollution Degree: 2; indoor use only.			
Note:						
The above specifications are subject to change without prior notice.						
*1 Power factor is tested on input voltage 400Vac with full output power						
*2 Efficiency is tested on input voltage 400Vac and operating voltage 250Vac with full output power						
*3 In the state of non-condensing						

## RPS-5000 Dimensions

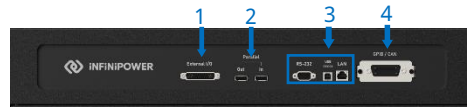

- 1 External I/O (AC\_ON, FAULT-OUT, Ext-ON/OFF, etc.).
- 2 Parallel Communication Interface
- 3 RS-232, Type-B USB, Network control interface
- 4 GPIB/CAN Optional Card
- 5 Input Circuit Breaker
- 6 Power Input Terminal
- 7 Protective & Functional Ground Terminal

- 8 Power Output Terminal
- 9 Remote Sensing Terminal
- 10 Power Input Cable Fixing Clamp

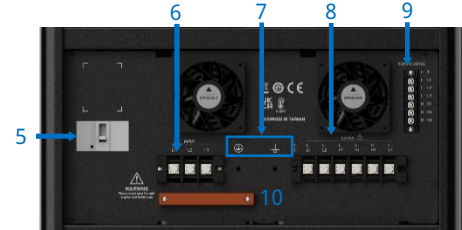

## Ordering Information

RPS - 5045 L - A - 0 - 0

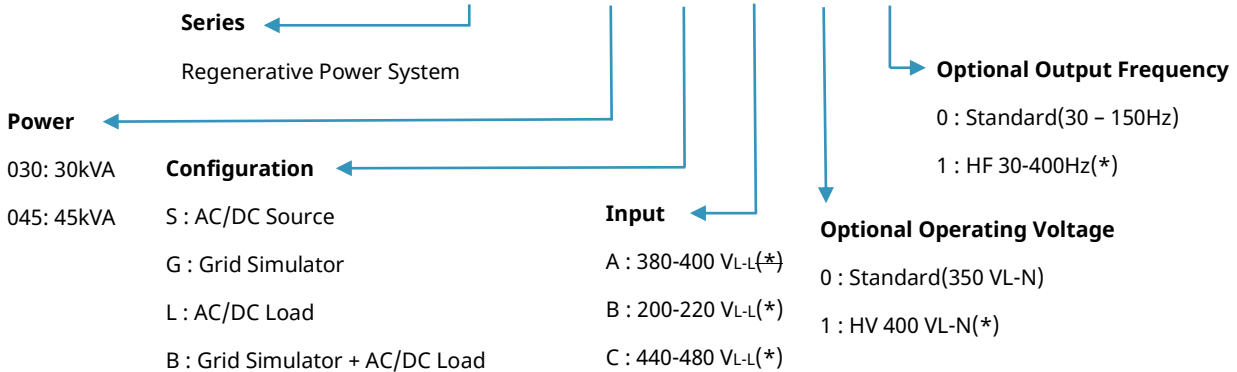

\* Special specifications, please contact the INFINiPOWER Tech. office or your local distributor

## Accessories list

Typical Delivery Items	Optional accessories
<ul style="list-style-type: none"> <li>■ Regenerative Power System</li> <li>■ Test Report</li> <li>■ USB cable (Type A to Type B) (1.5m)</li> <li>■ LAN cable CAT5E(2m)</li> <li>■ DB25 adapter board (for I/O signal)</li> <li>■ Output shorting adapter (for single phase mode)</li> <li>■ RPS-5000 series input power cable (3m)</li> </ul>	<ul style="list-style-type: none"> <li>■ Parallel cable (Display port) (1.2m)</li> <li>■ GPIB cable(1.5m)</li> <li>■ RS-232 cable(Female to Male)(1.8m)</li> <li>■ DB25 (male to male) adapter</li> <li>■ DB9(RS-232)(male to male) adapter</li> <li>■ Output voltage calibration fixture(Remote sense cable)</li> </ul>

\* Special specifications, please contact the INFINiPOWER Tech. office or your local distributor

## About INFINiPOWER

With over 20 years of expertise in power testing solutions, INFINiPOWER partners with leading global manufacturers and produces products in world-class smart factories to ensure high quality, stability, and reliability. Committed to precision and innovation, we empower our customers to focus on product development and safety validation.